

Aero C-3B 'Czechoslovak Bomber-Trainer'



V roce 1934 založil Hanns Klemm v Halle pobočku své firmy. Ta měla vyrábět, na rozdíl od mateřské továrny, vyrábějící celodřevěné letouny, vícemotorové letouny celokovové konstrukce. V roce 1937 převzal továrnu v Halle známý německý letec Friedrich Siebel a přenesl na ni své jméno. Továrna se zabývala hlavně licenční výrobou, ale konstruovala i vlastní typy. První konstrukcí nové továrny se stal Fh 104 Hallore, který vznikl ještě jako projekt v továrně Klemm.

V roce 1938 vypsala dopravní společnost Lufthansa ve spolupráci s RLM soutěž na rychlý dvoumotorový dopravní letoun. Než byla soutěž ukončena, vypukla válka. O letoun ale jevila stále zájem Luftwaffe. Prototyp letounu označeného Si 204A vzletl poprvé 23. 5. 1941. Tento dvoumotorový celokovový letoun byl poháněn dvojicí motorů Argus As 411 a od všech pozdějších verzí se odlišoval tím, že měl stupněnou příď. Byl zaveden do výroby, ale protože továrna v Halle byla vytížena výrobou Ju 88, byla výroba přenesena do Sociétés Nationale de Constructions Aéronautiques du Nord (SNCAN) ve Francii. Třetí prototyp byl vyroben jako nová verze Si 204D. Odlišoval se celoprosklenou příďí, podobnou jakou byly vybaveny bombardovací letouny He 111 H/P nebo Ju 88A. Hodil se tak skvěle k výcviku. I jeho výroby byla předána do SNCAN ve Francii a také do továren Aero, Letov a ČKD v Protektorátu Čechy a Morava. Poslední verzí vyvinutou za války byla Si 204E, vybavená střeleckou věží a pumovnicí v centroplánu. Ta byla určena k bombardovacímu výcviku. Nouzově mohla být použita i jako noční bombardér. Luftwaffe používala Si 204 hlavně v tzv. B a C školách a jako spojovací. Stroje vybavené radarem sloužily k výcviku nočního stíhání. Několik kusů používala během války i Lufthansa.

Konec války ale neznamenal konec historie Si 204. Siebel Si 204 měl skvělé letové vlastnosti, byl spolehlivý a výkonný. Dost letounů zabavili vítězové. Ukořistěné Si 204 tak testovaly nebo používaly britská RAF, USAAF, sovětské letectvo i Aeroflot, Československé letectvo i ČSA a francouzské Armée de l'Air i Aeronavale. Výroba ve Francii u SNCAC pokračovala i po válce, stejně jako v Československu. Ve Francii vyráběný Si 204, v několika verzích, byl označen NC 700 až 702 a pojmenován Martinet. Byl dokonce exportován do Švédska a Polska. Československé Si 204 byly označovány podle verze C-3A/B, C-103 a D-44. Jejich výroba pro nově budované československé letectvo i státní aerolinie ČSA se rozeběhla hned po válce. Měly být používány jen k výcviku. Díky komunistickému převratu a nemožnosti je nahradit z různých důvodů jinými typy tvořily ale výzbroj bombardovacích jednotek ČSLA až do jejich náhrady proudovými Il-28 v polovině padesátých let.

Si 204D TTD

Rozpětí 21,28 m, délka 11,95 m, max. rychlost 364 km/h ve výšce 3 000 m, praktický dostup 7 500 m, dolet 1 800 km.



In 1934 in the German city of Halle, Hanns Klemm, an aircraft designer and manufacturer, set up a branch of his aircraft factory. The new plant was to produce multi-engined, all-metal aircraft, in contrast to the original factory where wood was still being used for building the aeroplanes. In 1937, the Halle plant was taken over by the famous German aviator Friedrich Siebel who also gave it his name. The plant mainly focused on licence-built designs, but had a couple of their own aircraft designs too. The first type to be produced by this new plant was the Fh 104 Hallore, a design in fact originating in the Klemm works.

In 1938, Germany's flag carrier Deutsche Luft Hansa in cooperation with the RLM announced a tender for a fast, twin-engined transport aircraft. Before the winning design could be found, the war had broken out which meant the new type would be used just (or mainly) by the German military. The prototype Si 204A first flew on 23 May 1941, being of an all-metal construction and powered by a pair of Argus As 411 engines and differed from all later versions by having a stepped pilots' canopy. Its production was commenced at the Halle plant at first but as their workers were busy with producing Ju 88 bombers, the production was later transferred to the French Sociétés Nationale de Constructions Aéronautiques du Nord (SNCAN). The third prototype machine was finished as the new Si 204D version which had a completely glazed pilots' cabin, similar to that of the He 111H/P and Ju 88A bomber aeroplanes and in this new configuration, the type perfectly suited to the trainer role. The Si 204D was produced not just by the French plant, but in the Protectorate of Bohemia and Moravia (former Czechoslovakia) by Aero, Letov and CKD factories too. The final variety to be developed during the war time was the Si 204E which featured a gun turret and bomb bay in the central section of the fuselage, enabling the type to take part in the bomber crew training or it was even used as a makeshift night fighter. The German Luftwaffe operated the Siebel mainly in so-called B- and C- flight training schools and as a liaison aircraft. The machines which were fitted with radar equipment were used for night fighter training and a handful of the Si 204 was also operated by the Deutsche LuftHansa during the war.

The end of the Second World War did not bring the career of the type to an end, the Siebel proved to possess marvelous flying capabilities, was reliable and also quite efficient. Several of the Si 204 were taken over by the victorious Allies and were test flown by or even put to regular service with the British RAF, USAAF, Soviet air force, Aeroflot (Soviet Airlines), Czechoslovak air force, ČSA (Czechoslovak Airlines) and French Armée de l'Air and Aeronavale. The post war production went on at both the French SNCAC and Czechoslovak plants. The French machines were known as the NC700 to NC702 and dubbed the Martinet and were also exported to Sweden and Poland. In Czechoslovakia, the various indigenously built versions of the Siebel were put to service as the C-3A/B, C-103 or D-44 respectively. At first, they were to serve for training purposes only, but the 1948 communist coup and various other reasons meant that no other and more advanced types would be available to replace them eventually, so they went on to serve with the bomber units of the ČSLA (Czechoslovak Air Force) well until the mid 1950s when they were replaced by the Il-28 jets.

Si 204D characteristics and performance:

Wingspan 21.28 m, length 11.95 m, max. speed 364 km/h at 3,000 m, service ceiling 7,500 m, range 1,800 km.

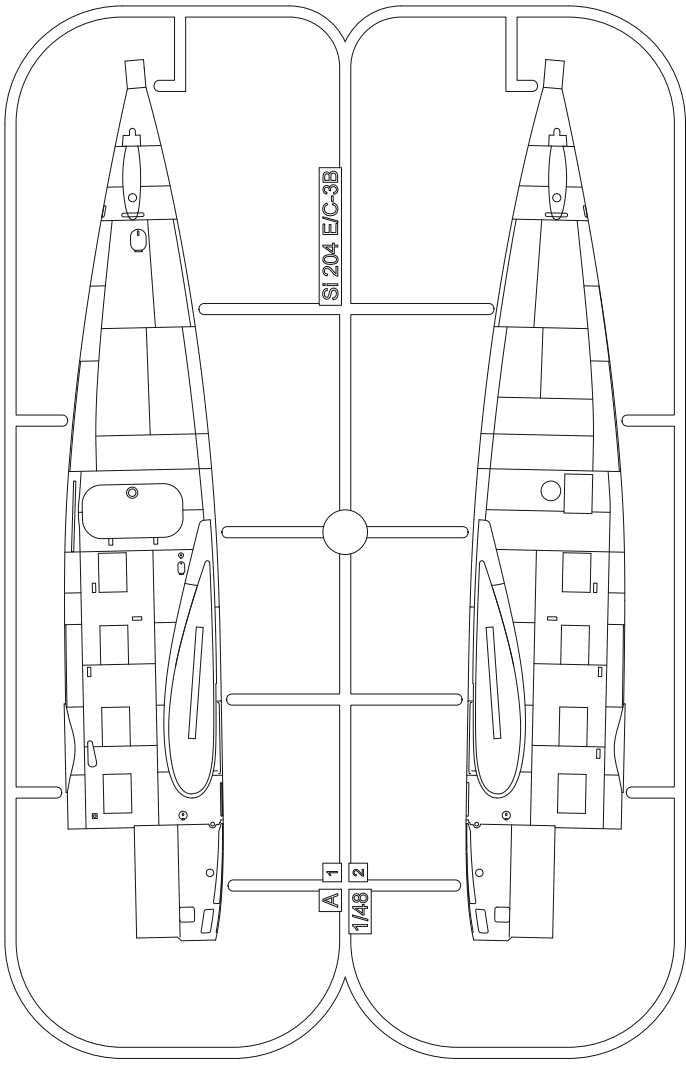

A B

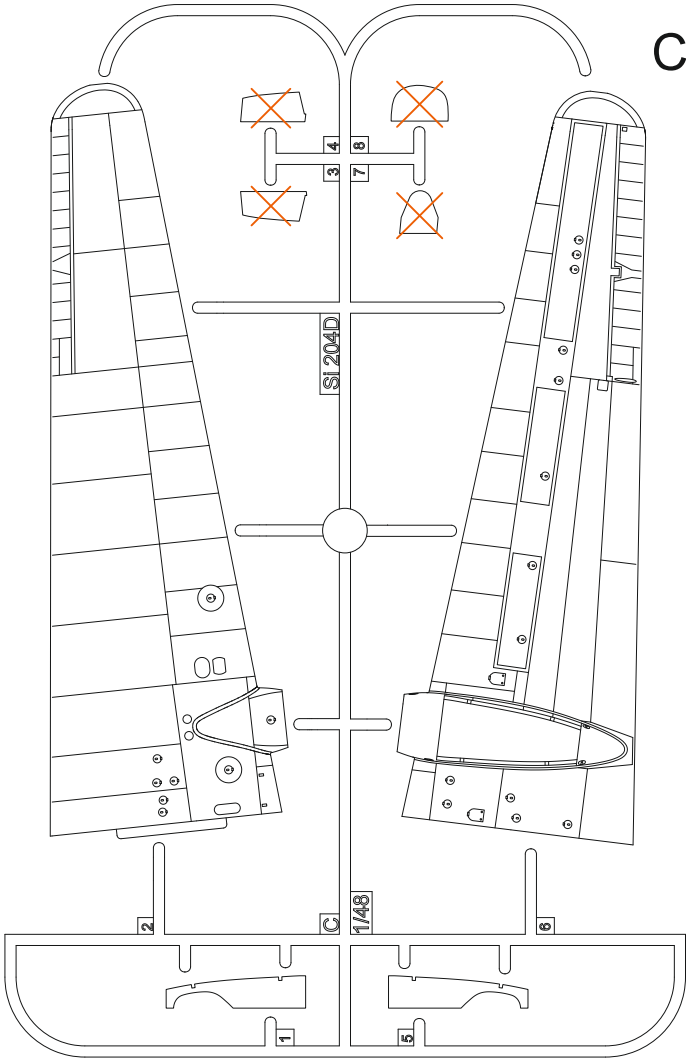
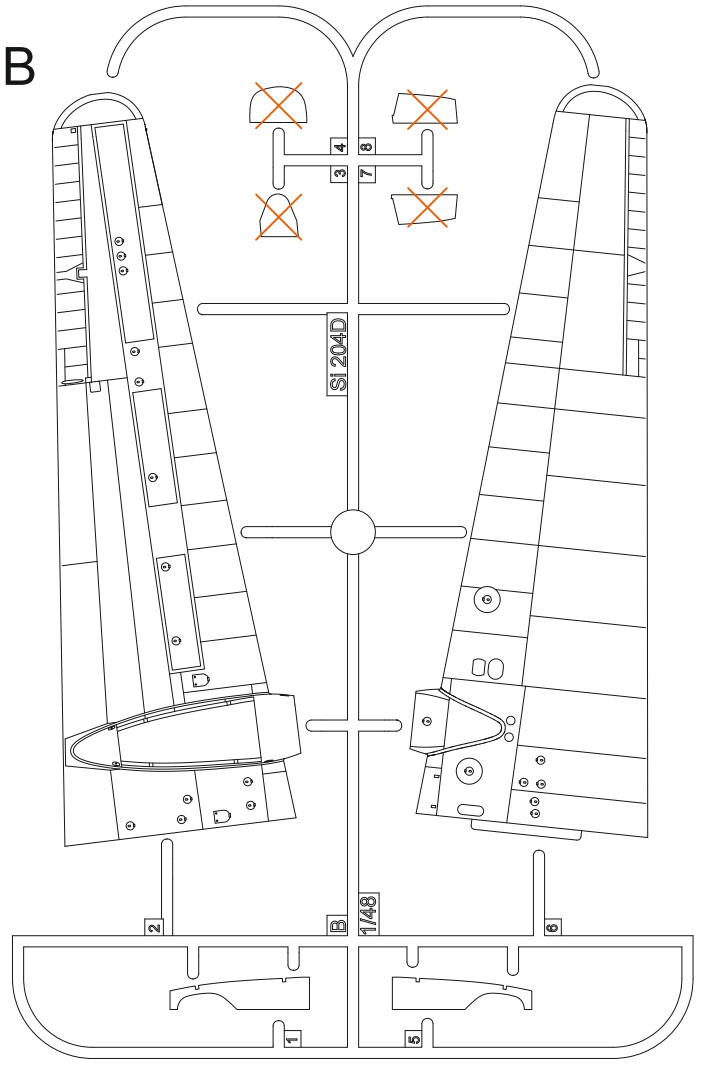

C D

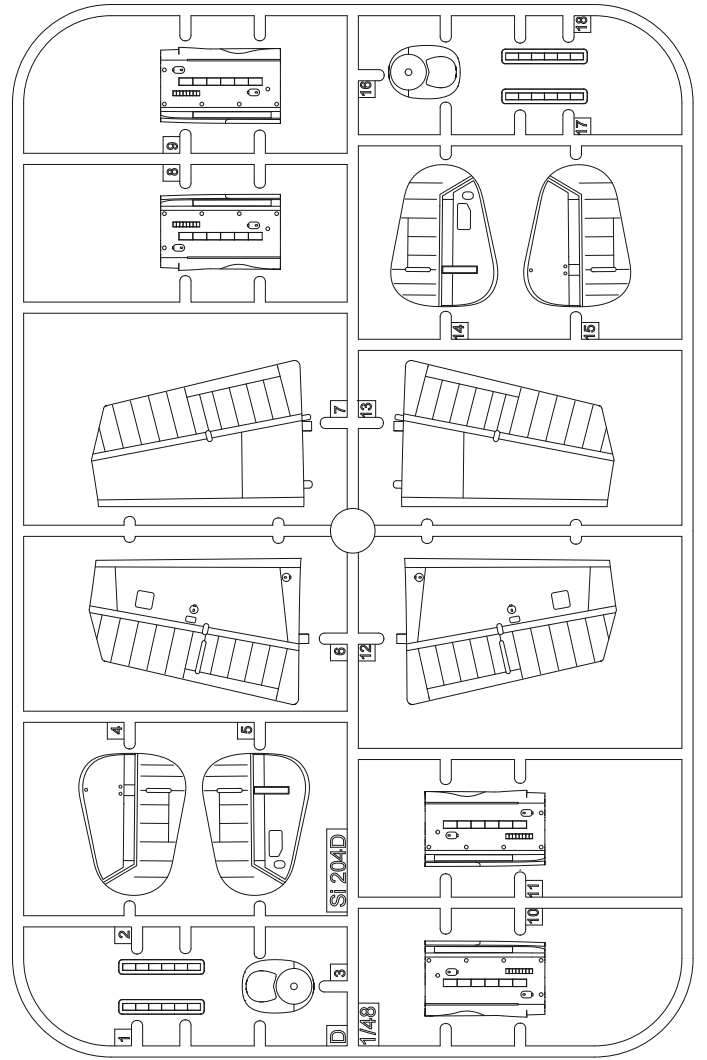

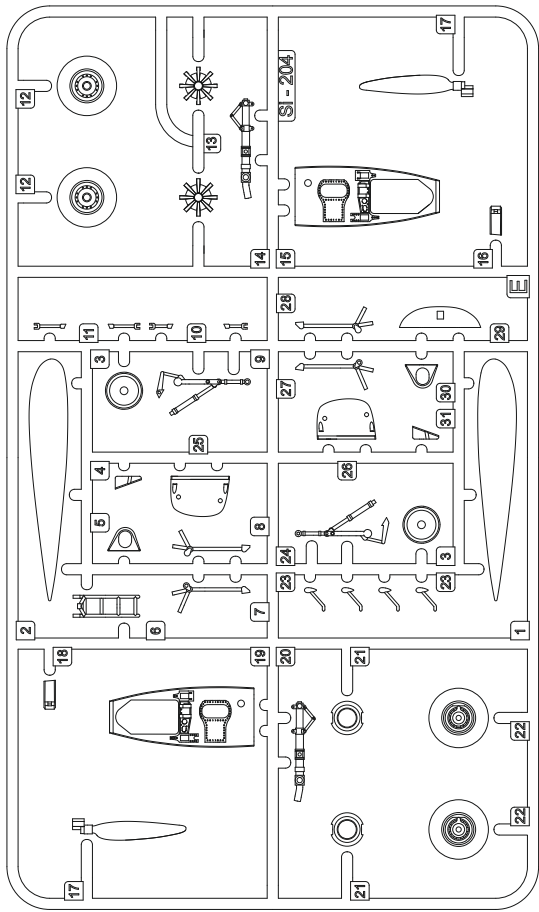

M

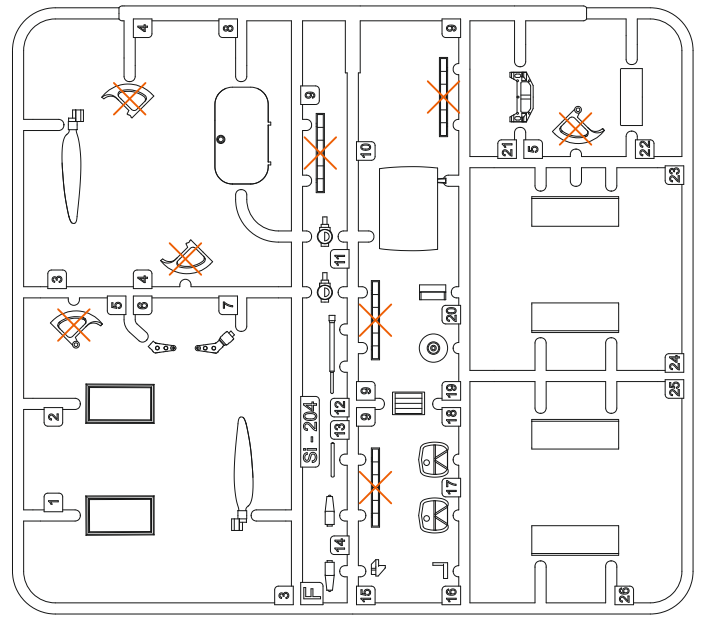

F

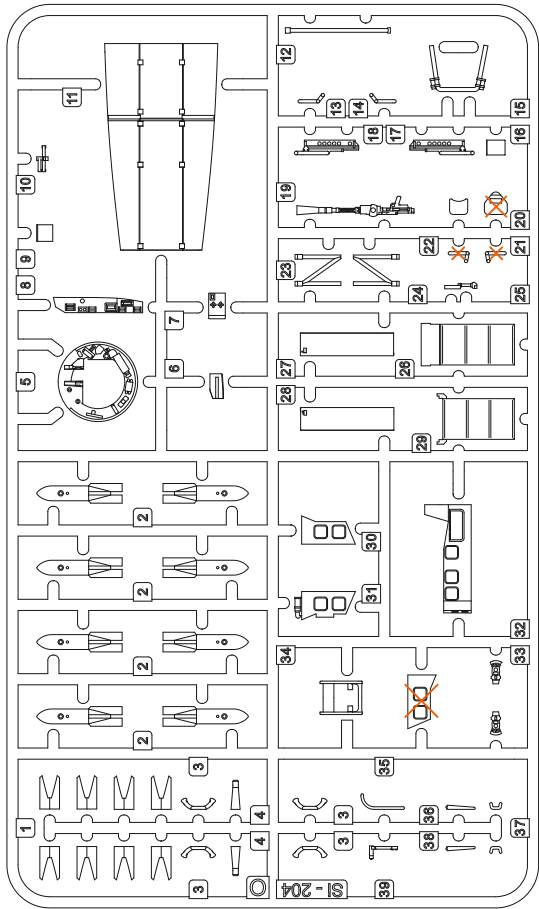

O

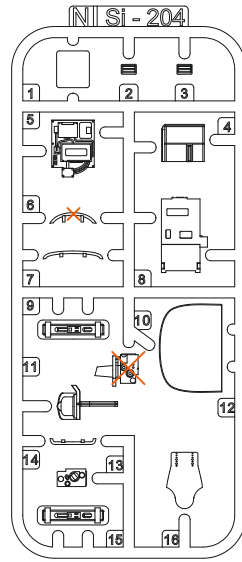

N

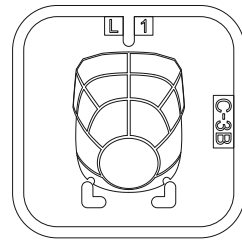

L

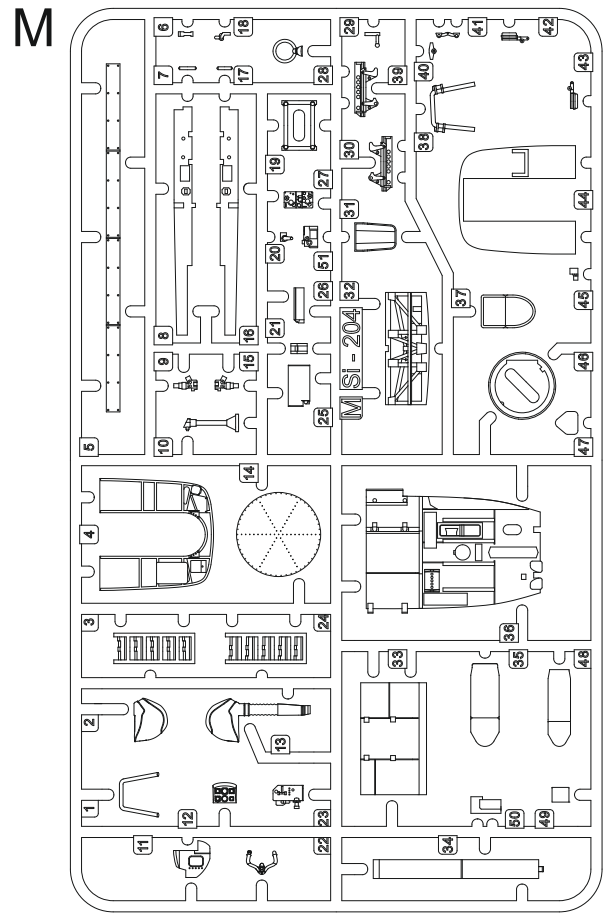

M

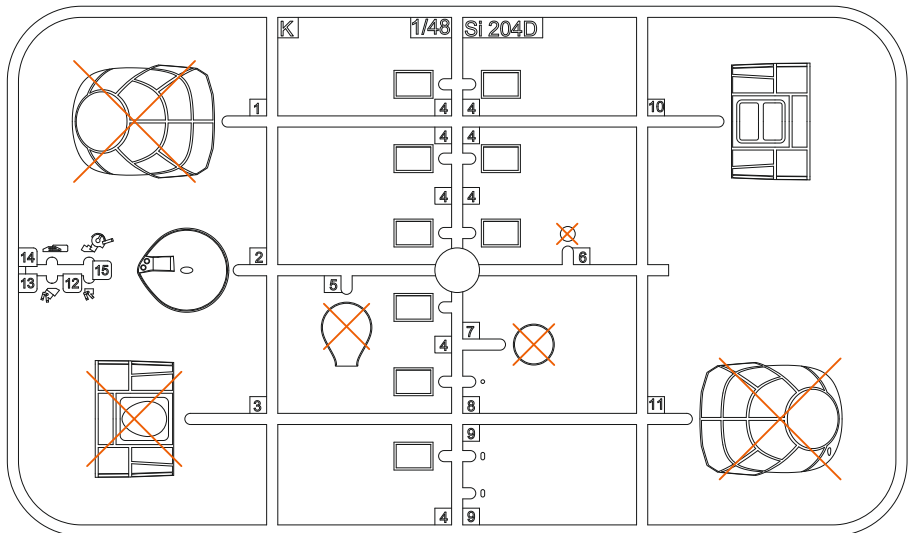

K

 *Tento díl nepoužít*
Do not use this part

STEP 1

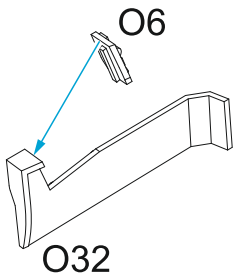

STEP 2

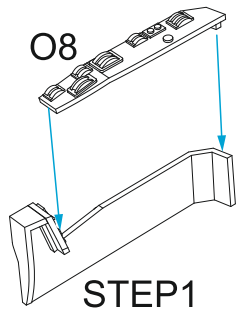

STEP 3

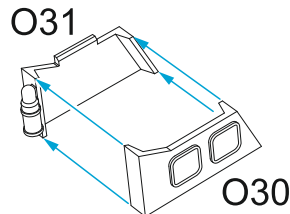

STEP 4

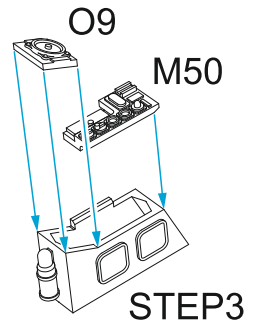

STEP 5

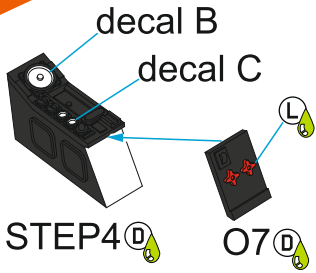

STEP 6

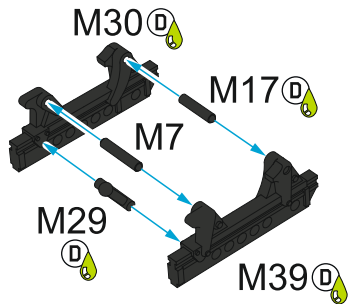

STEP 7

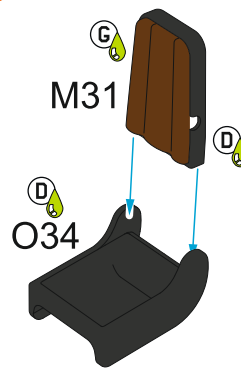

STEP 8

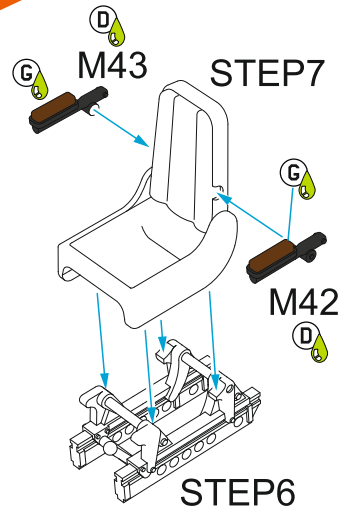

STEP 9

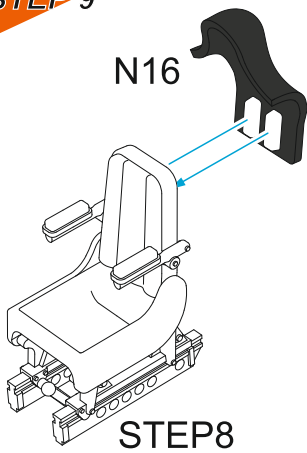

STEP 10

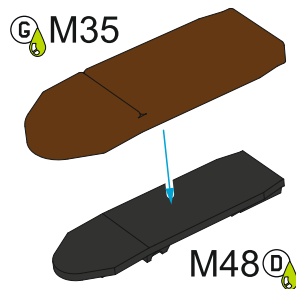

STEP 11

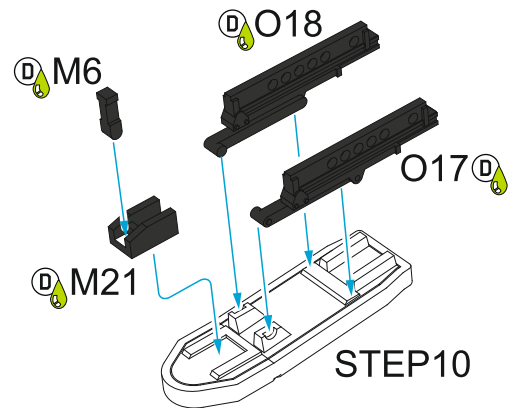

STEP 12

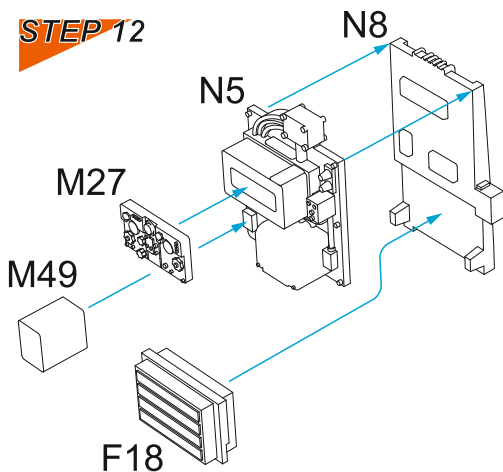

STEP 13

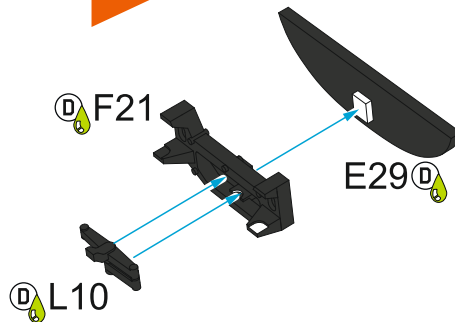

STEP 14a

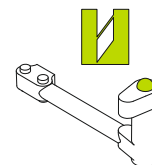

STEP 14b

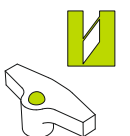

STEP 15

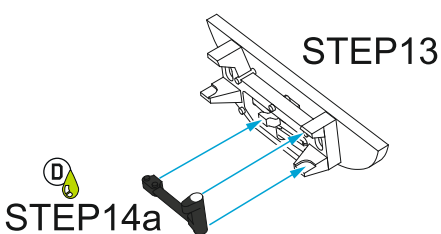

STEP 16

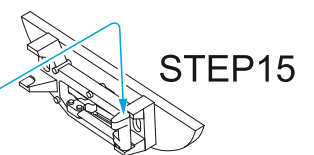
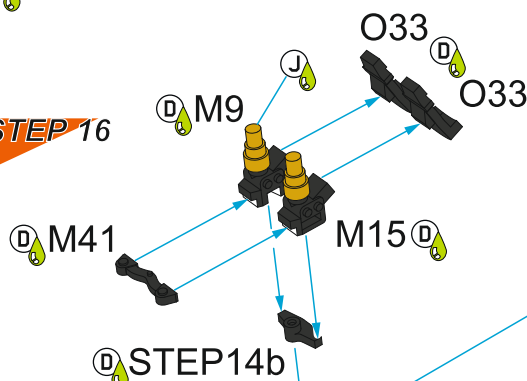

STEP 17

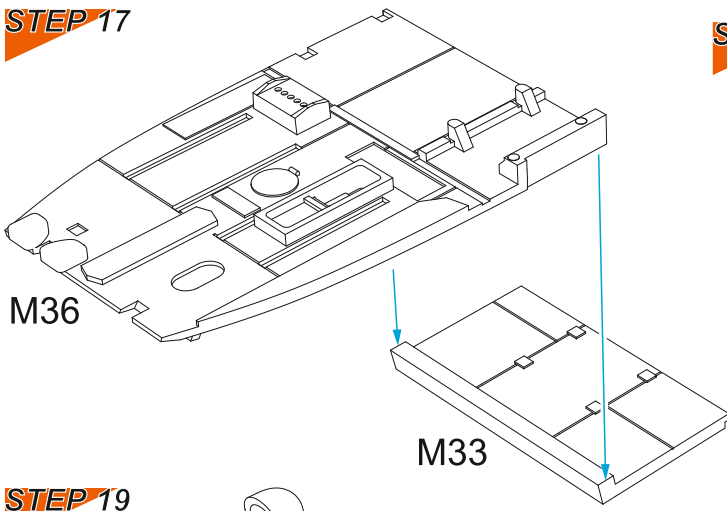

STEP 18

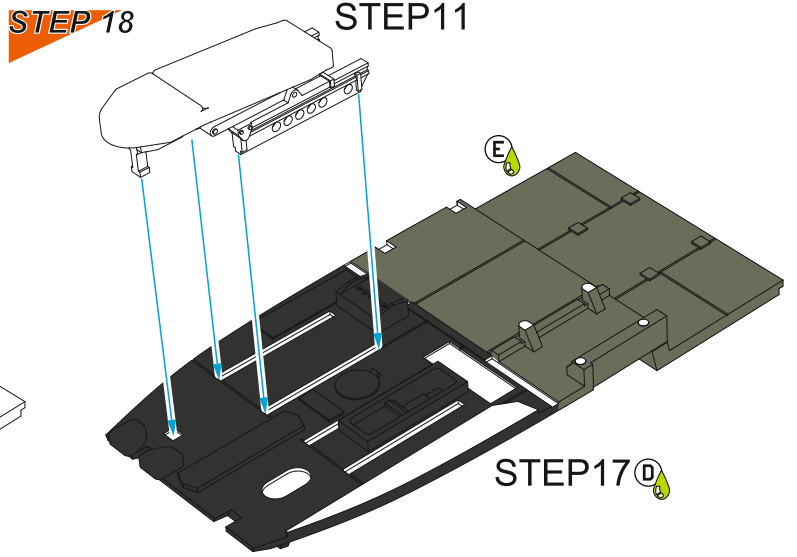

STEP 19

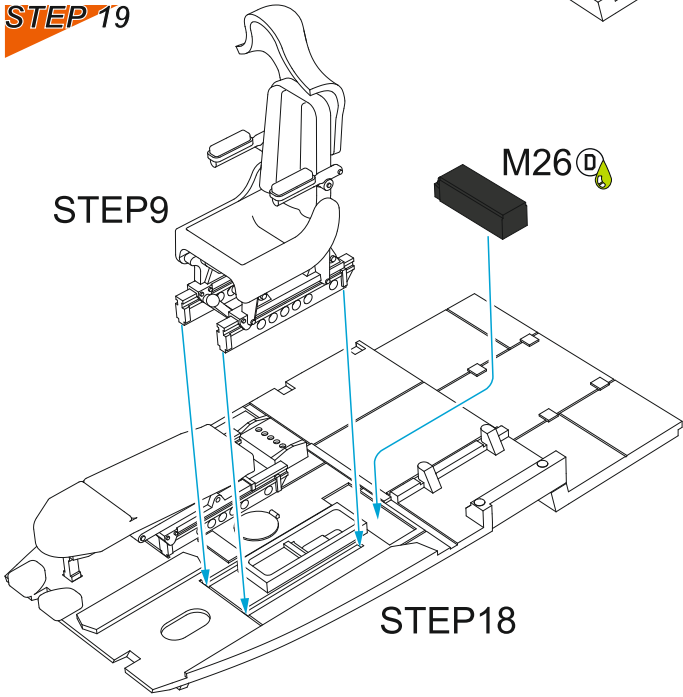

STEP 20

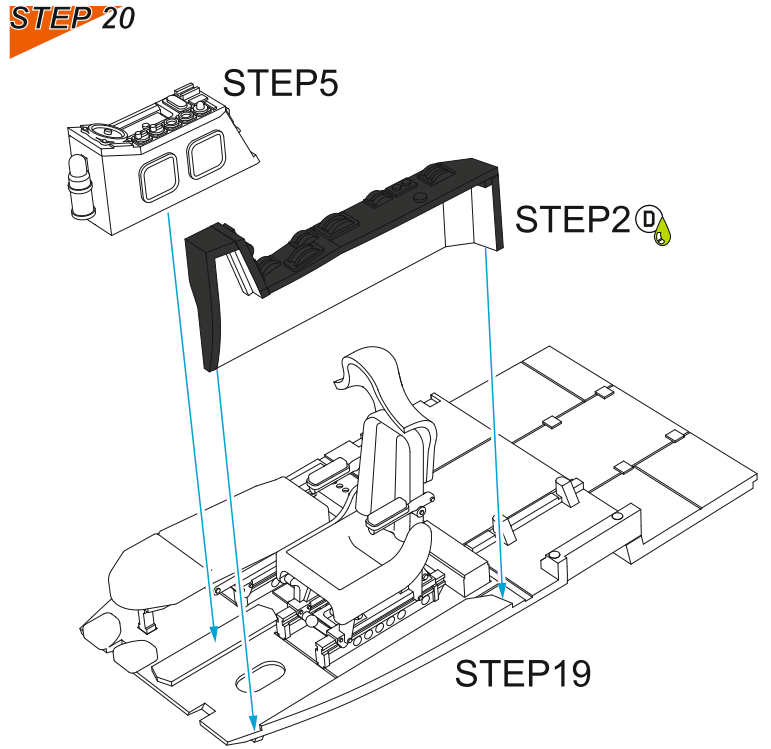

STEP 22

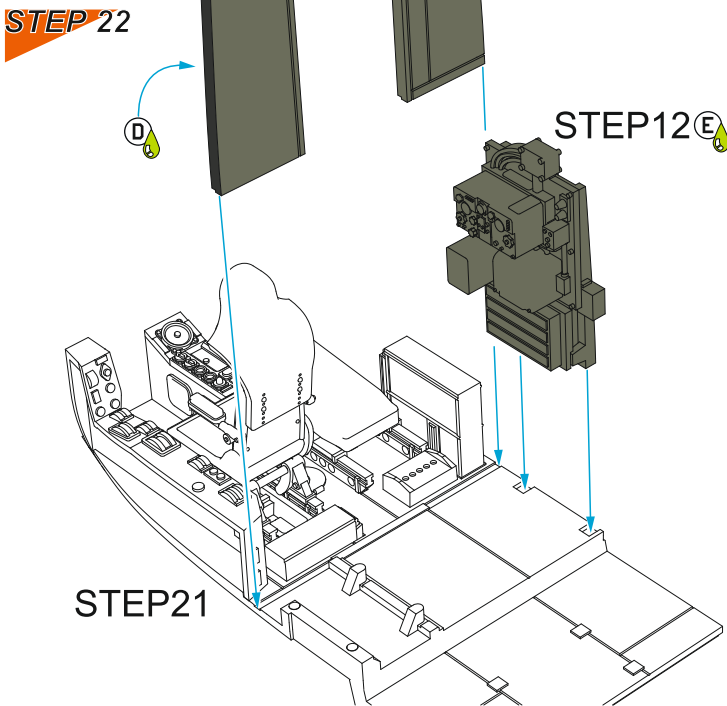

STEP 21

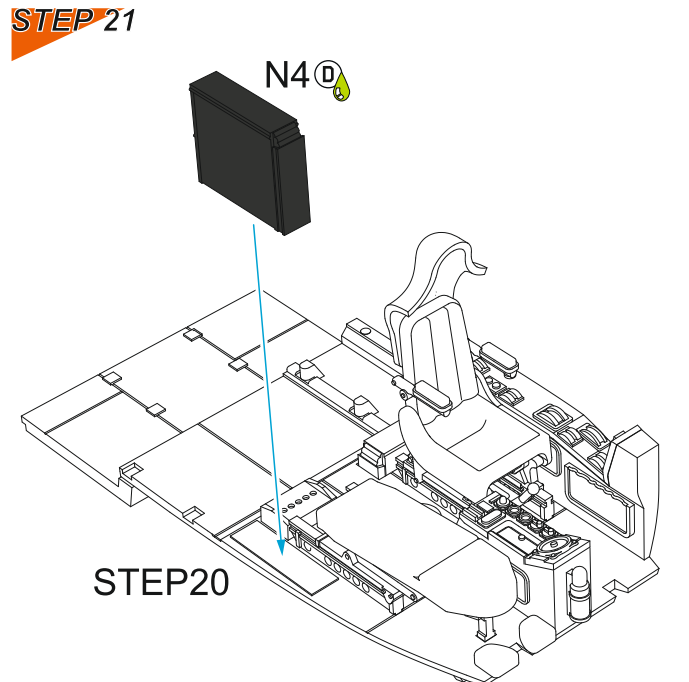

STEP 23

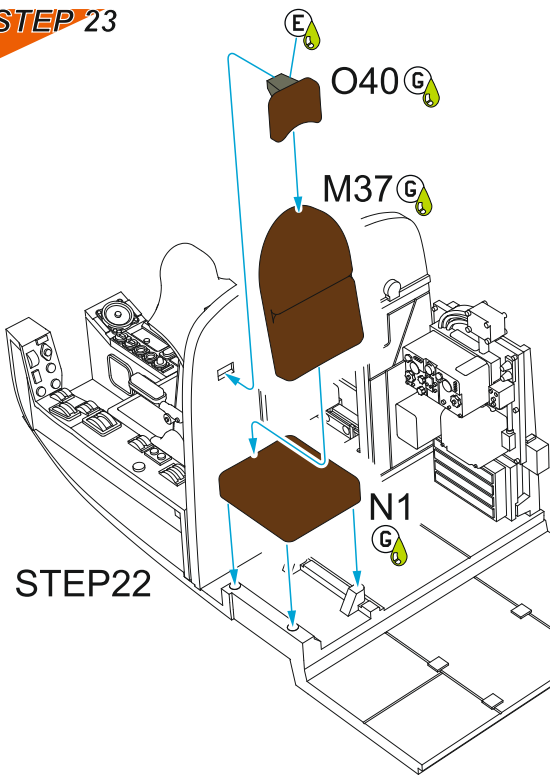

STEP 24

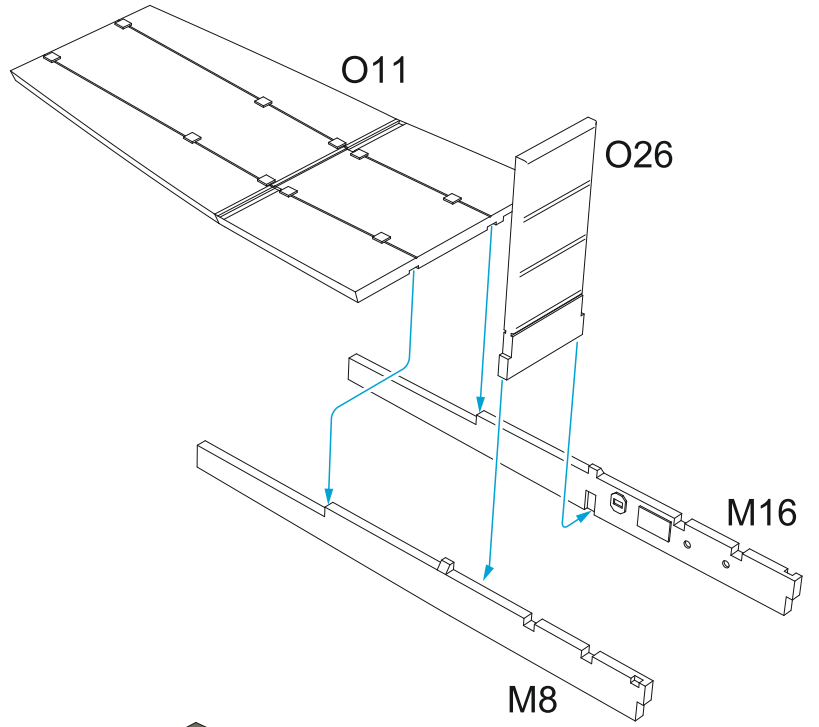

STEP 25

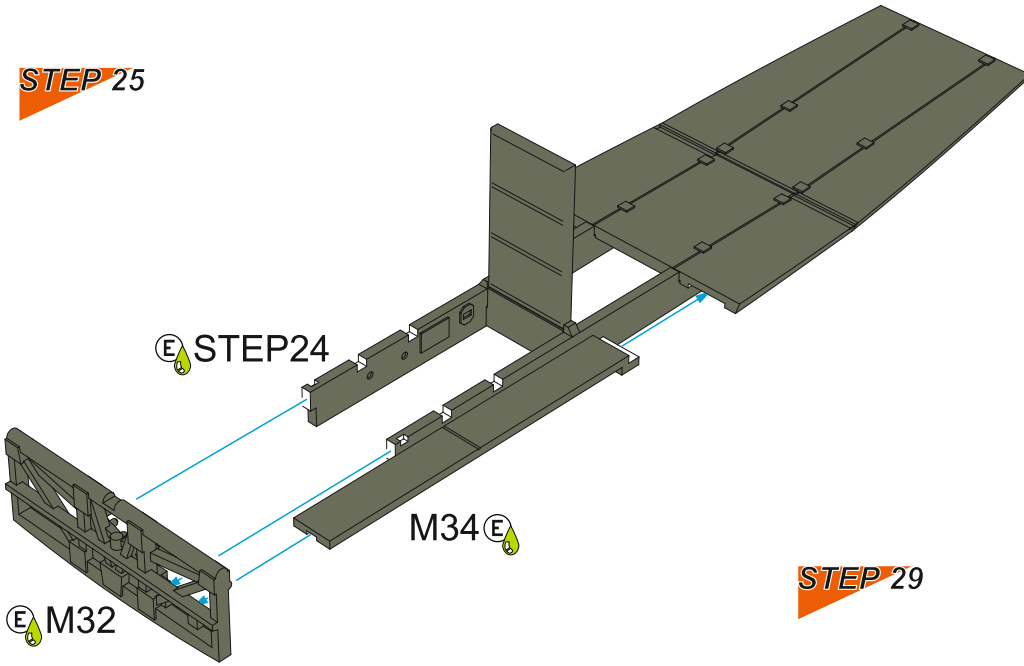

STEP 26

8x

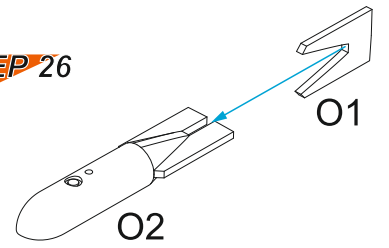

STEP 29

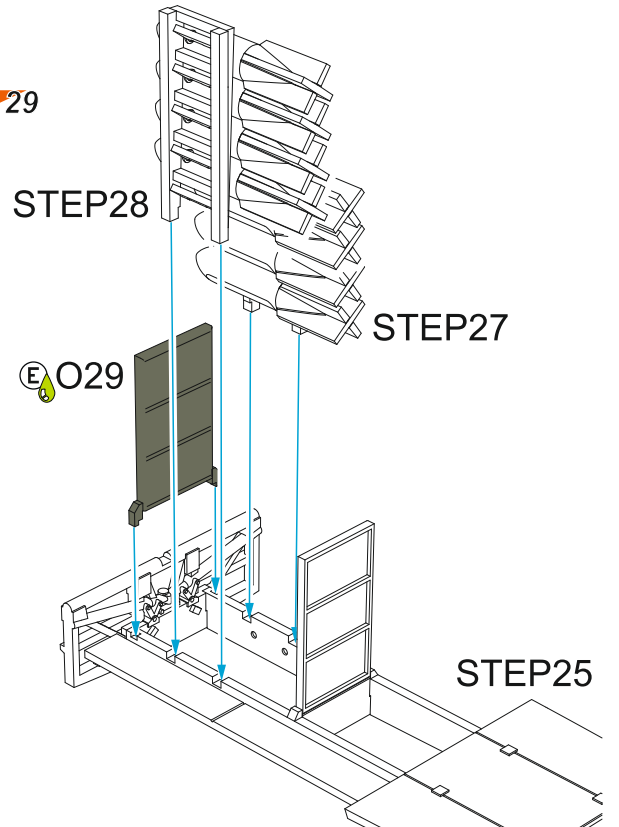

STEP 27

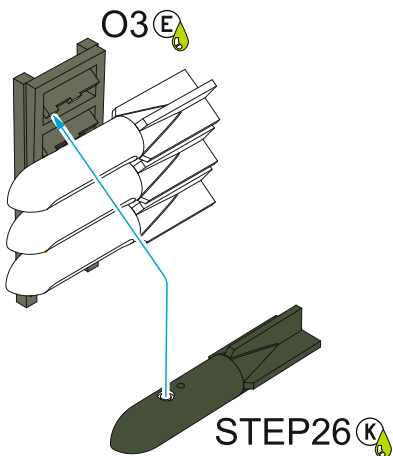

STEP 28

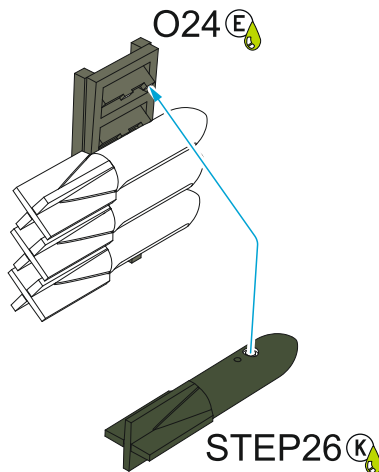

STEP 30

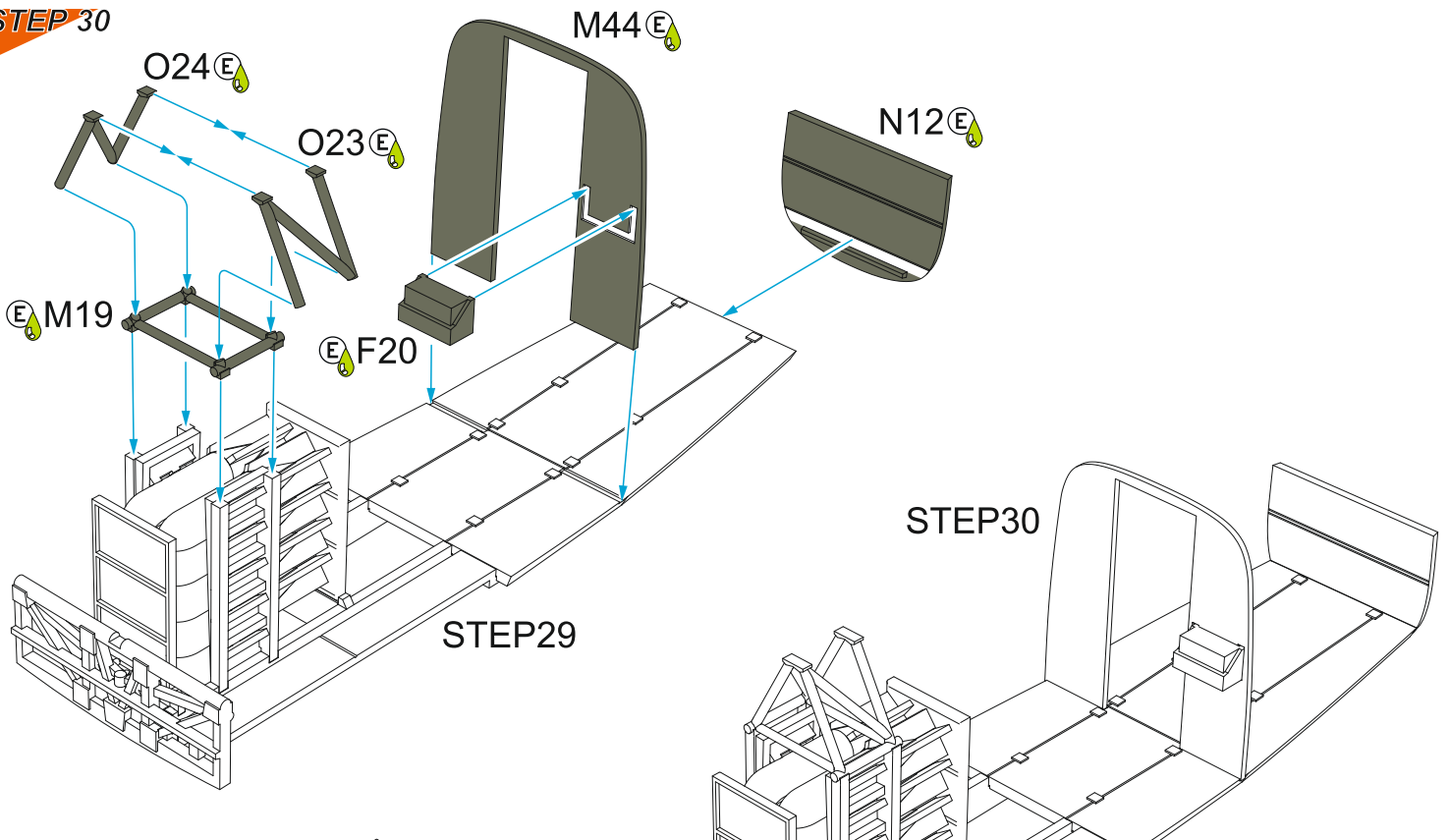

STEP 31

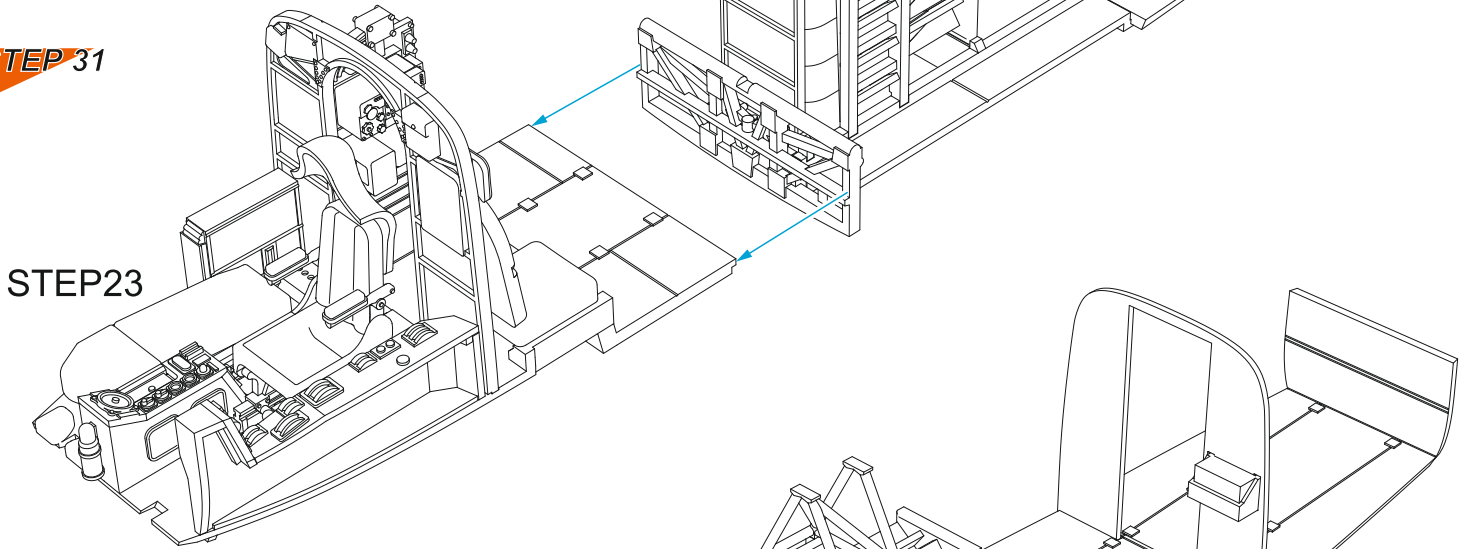

STEP 32

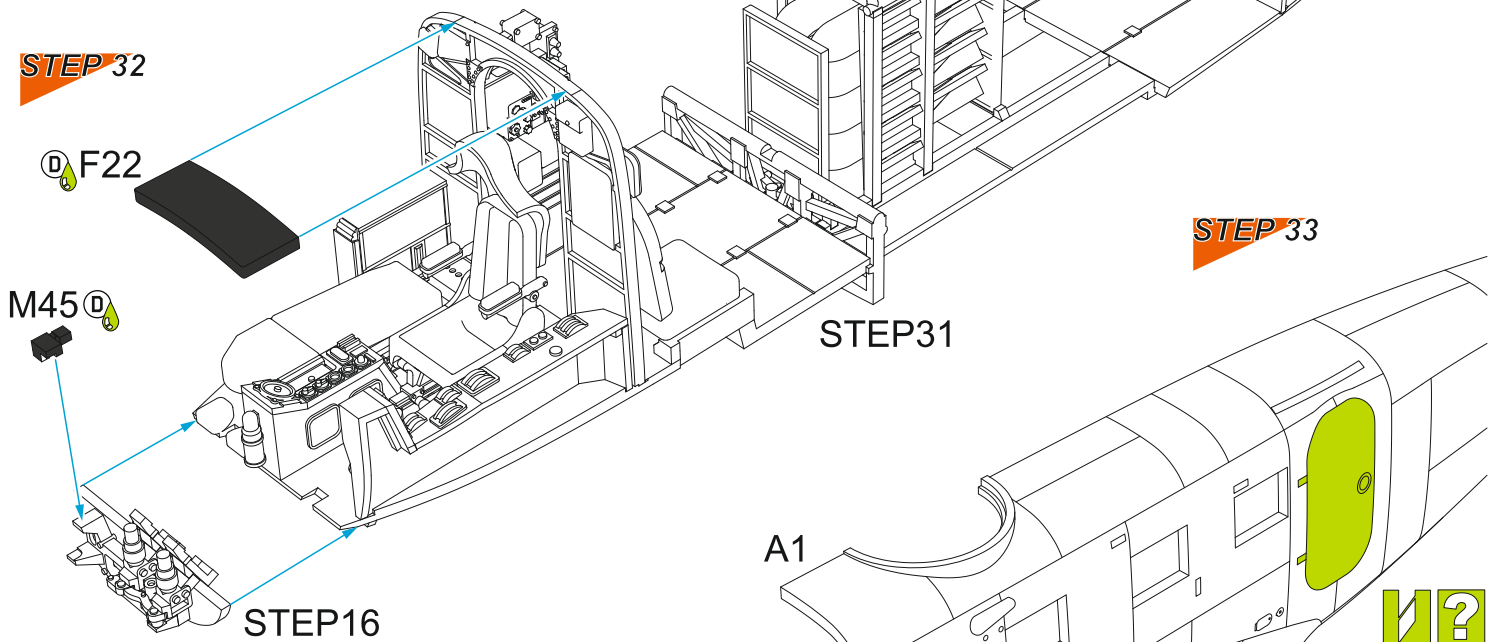

A1



STEP 34



STEP33/ A1

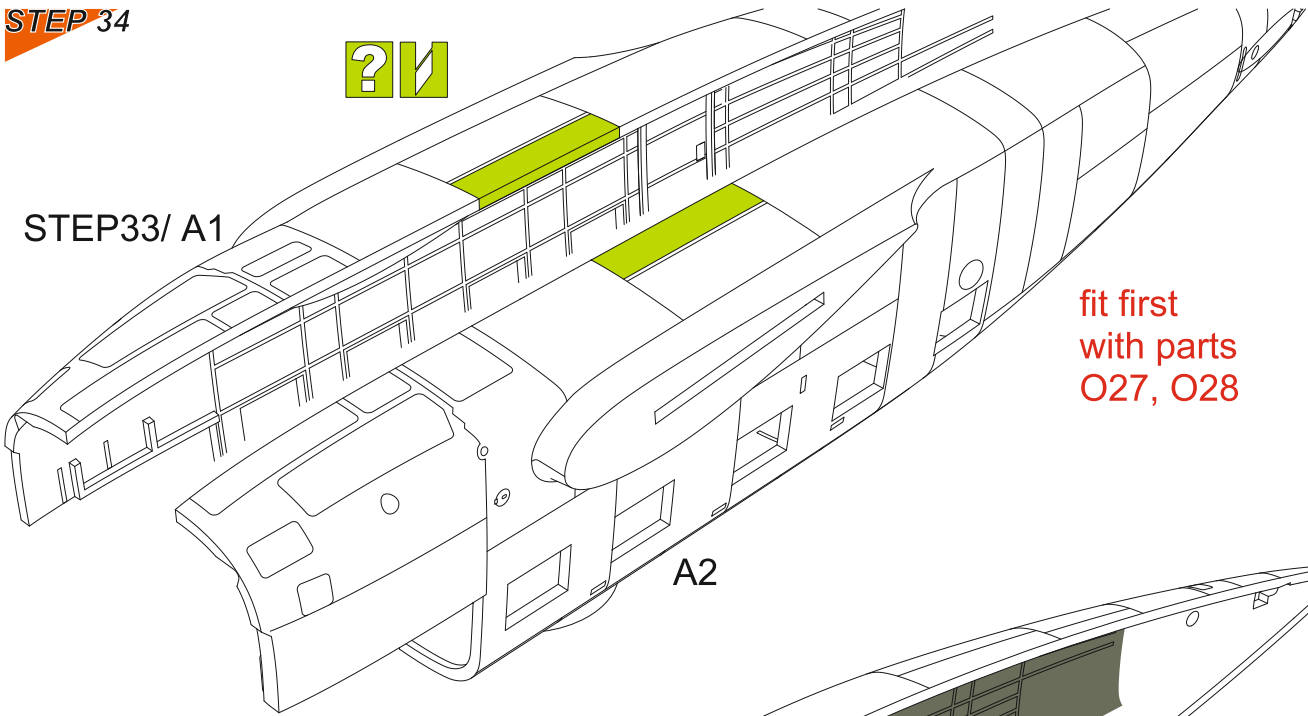

fit first
with parts
O27, O28

A2

STEP 35

STEP34/ A2

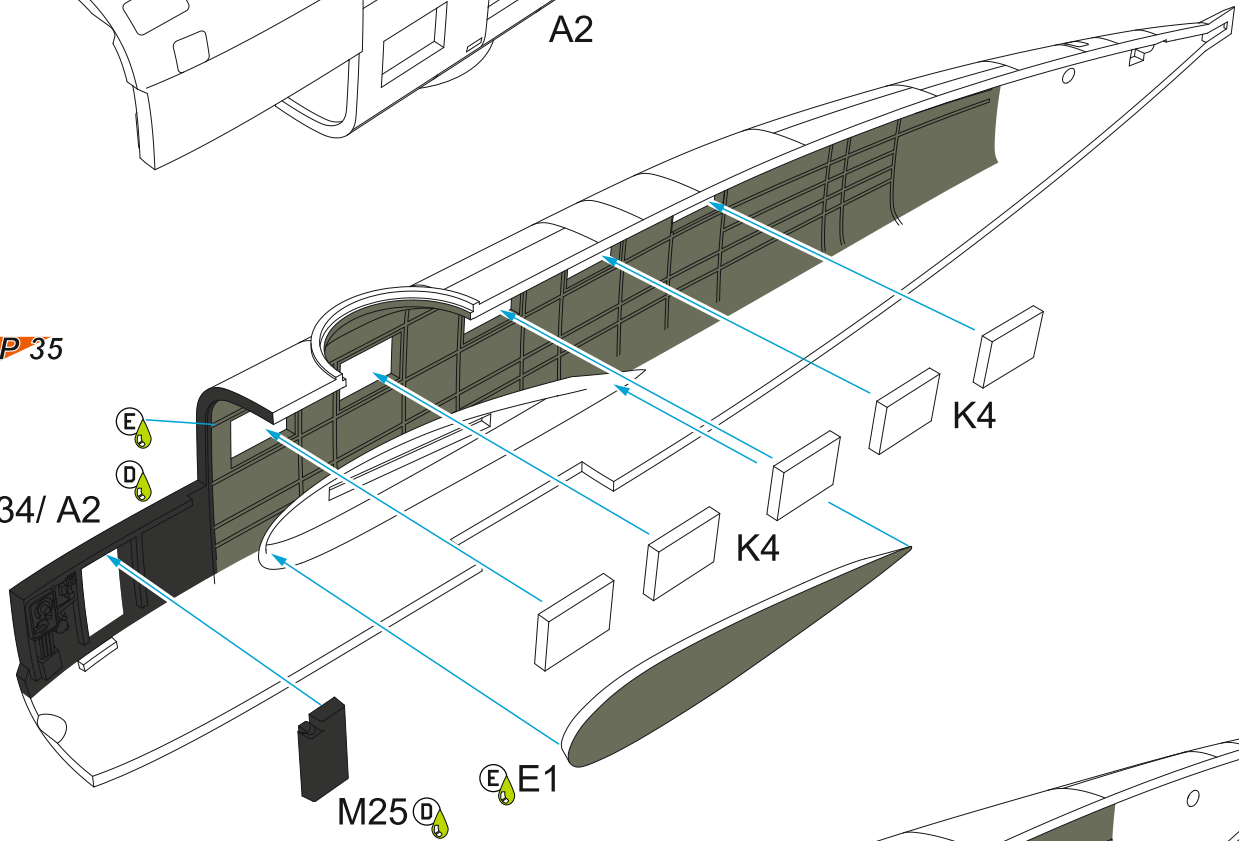

STEP 36

STEP34/ A1

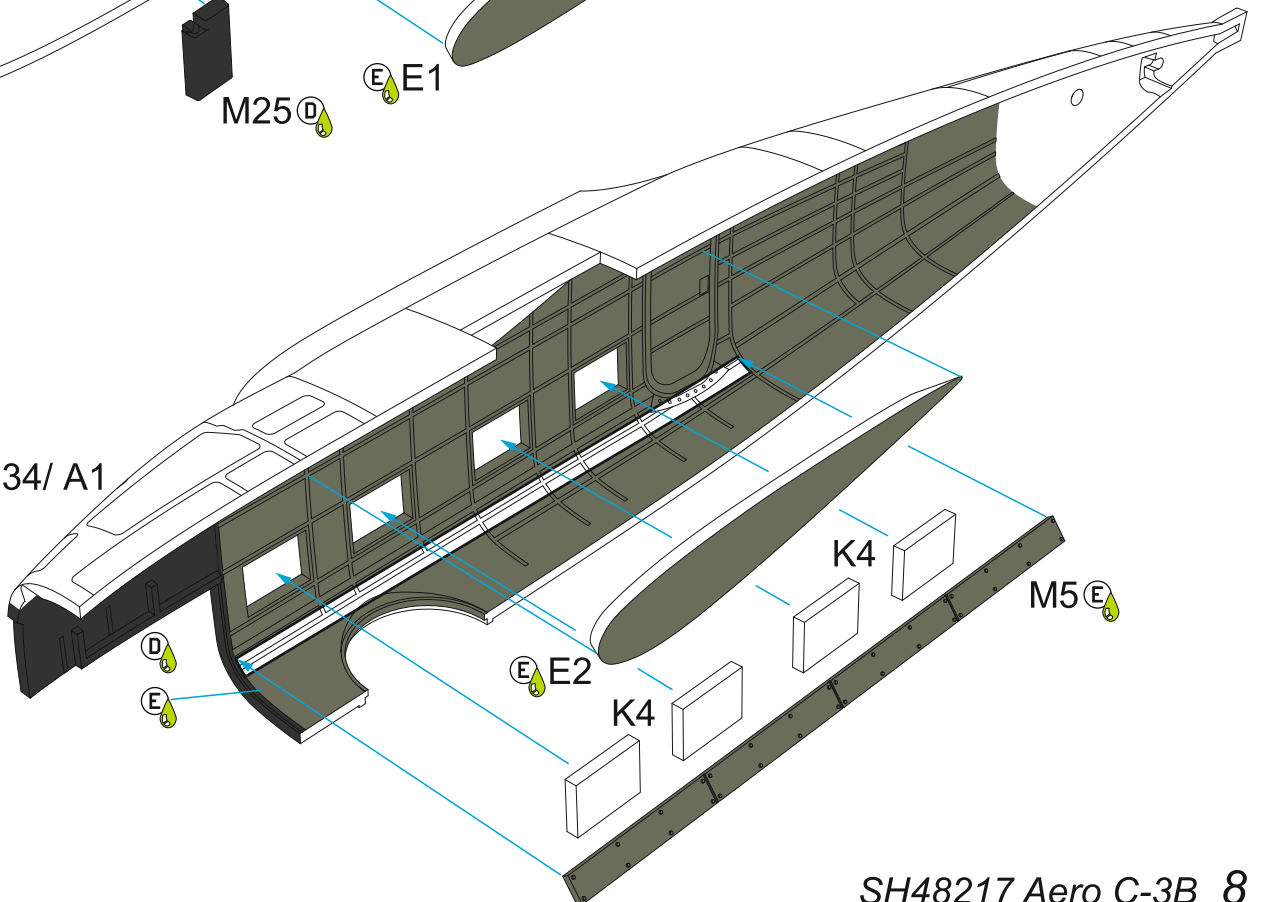

STEP 37

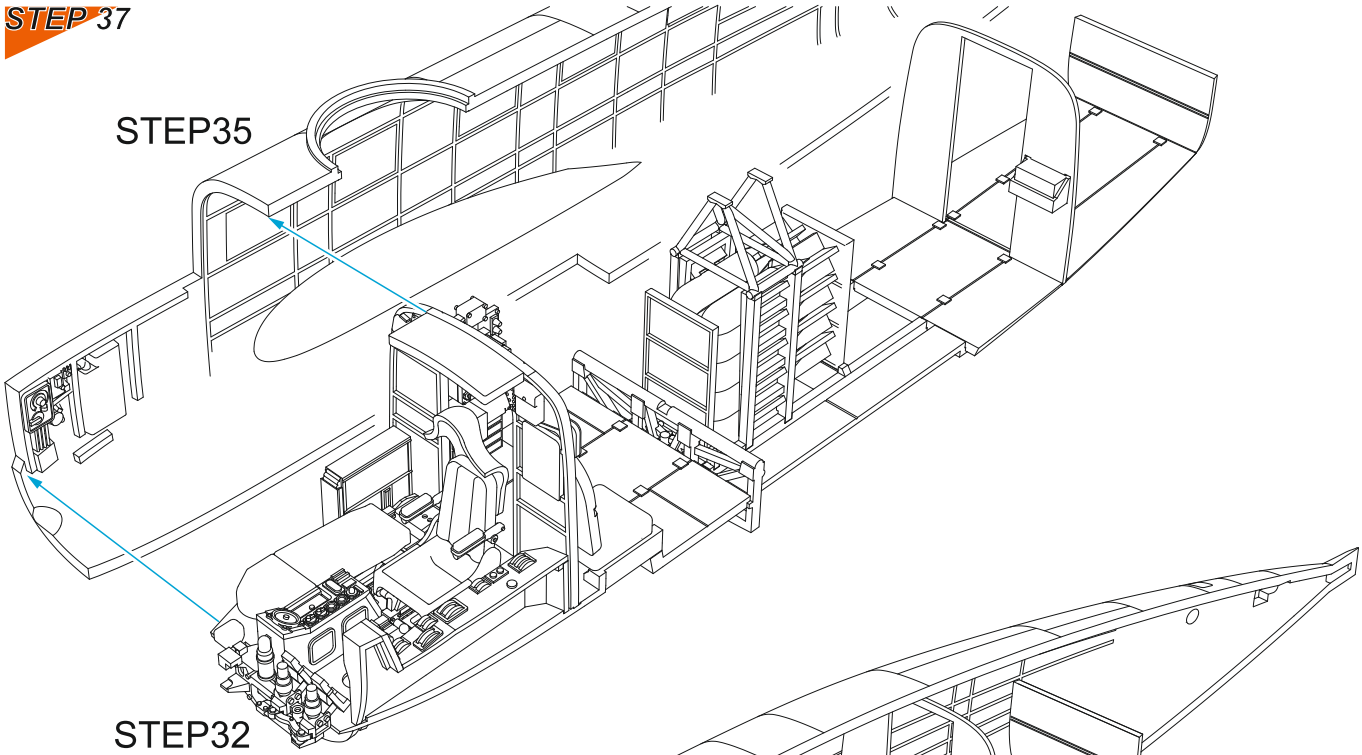

STEP 38

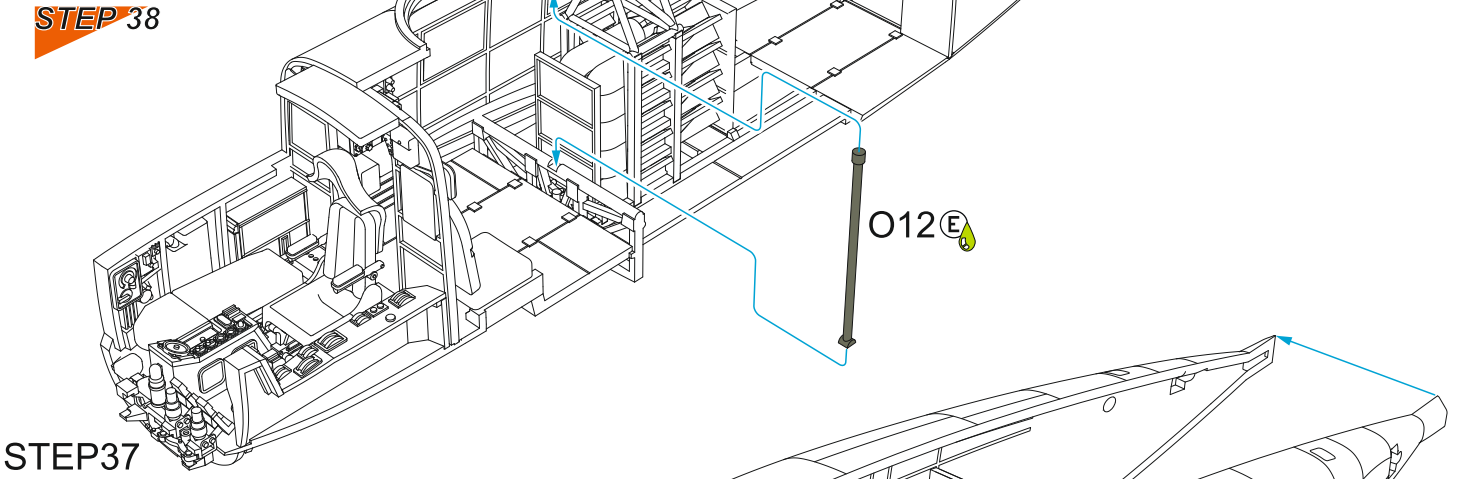

STEP 39

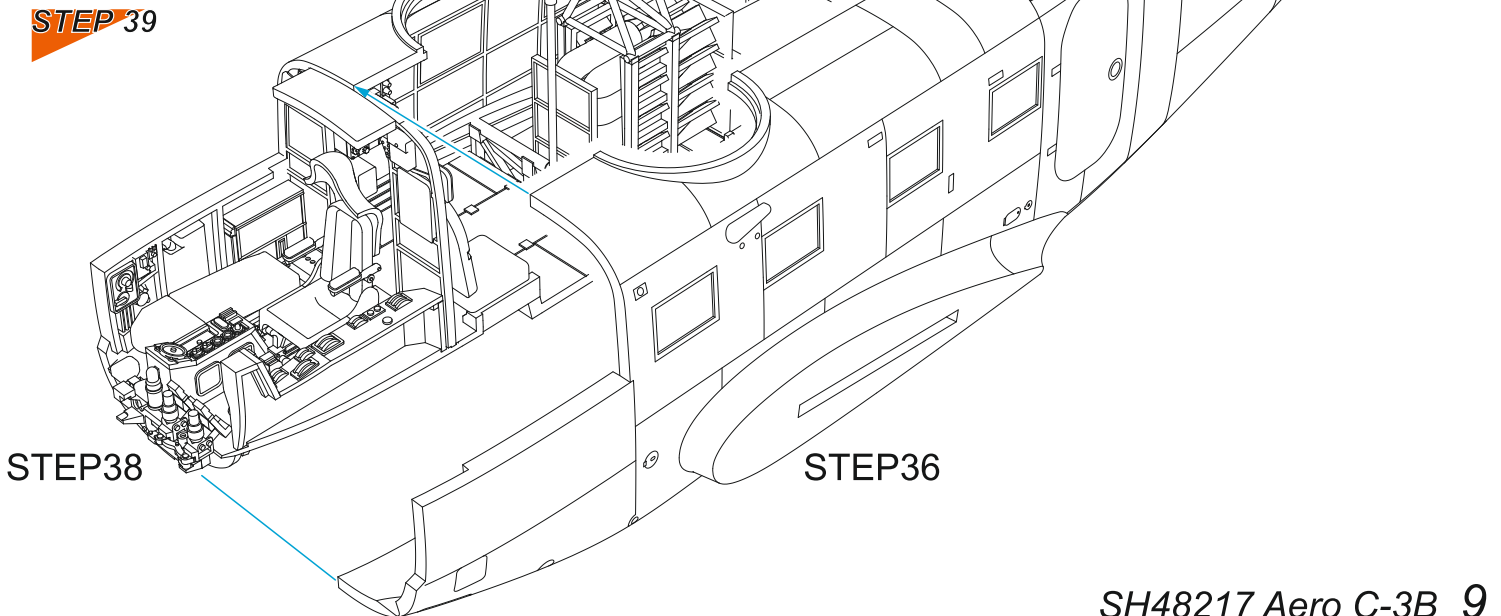

STEP 40

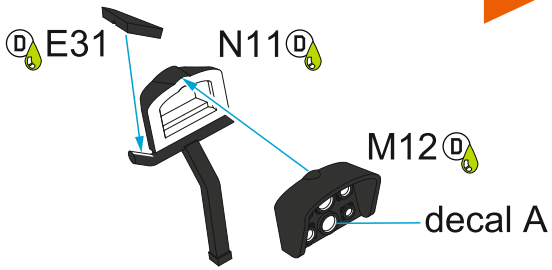

STEP 41

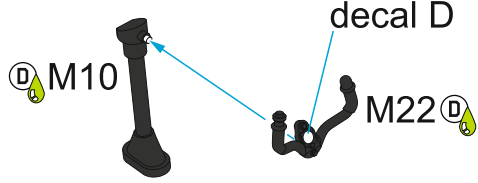

STEP 42

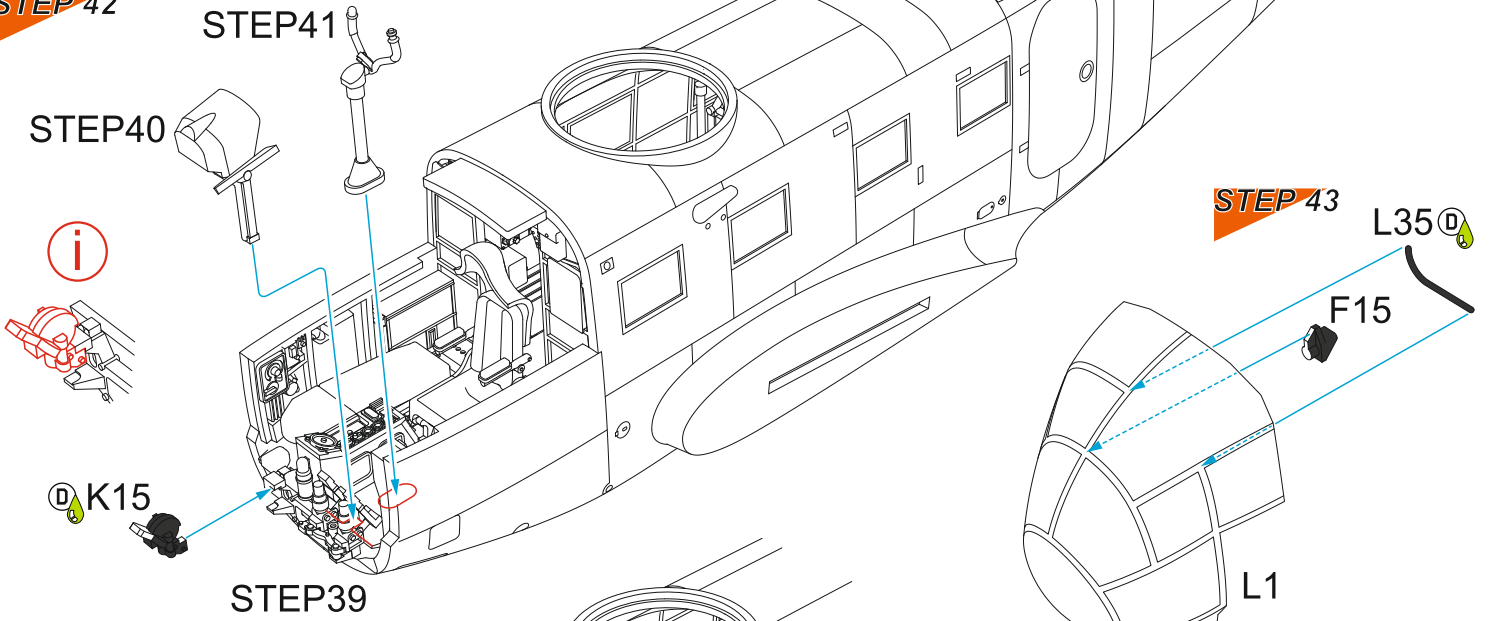

STEP 43

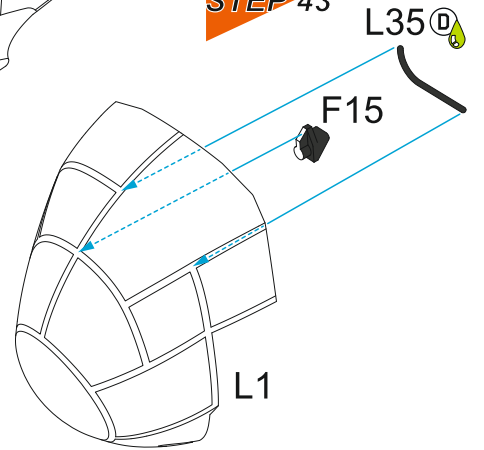

STEP 45

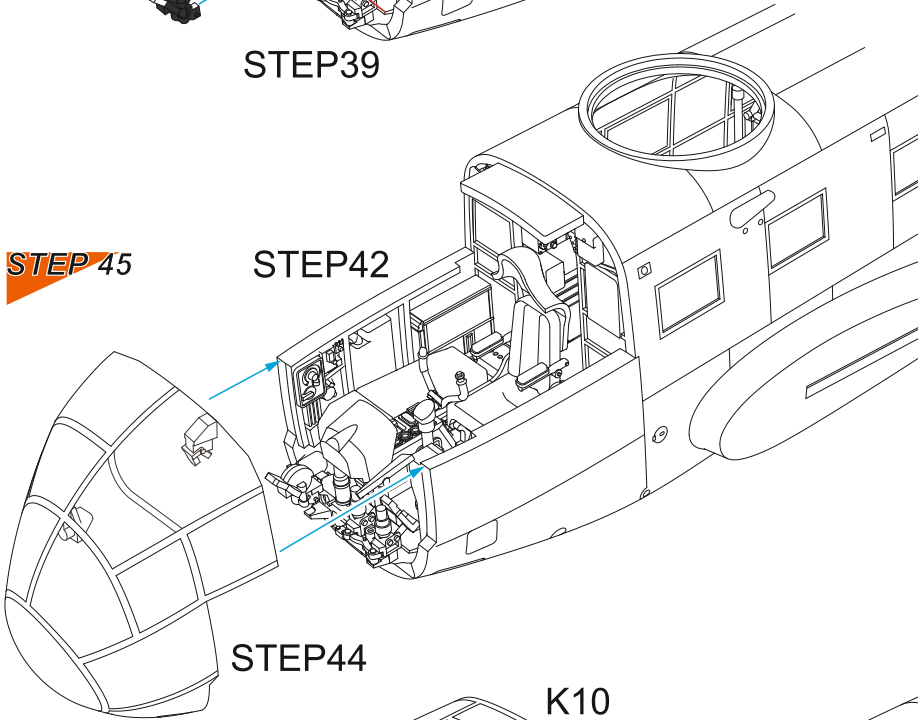

STEP 44

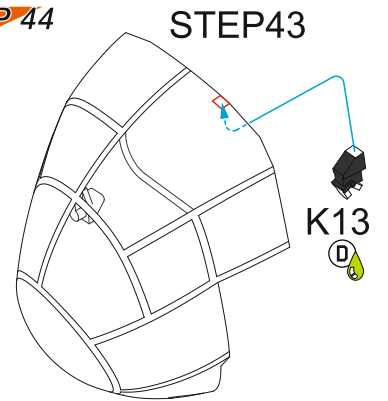

STEP 46

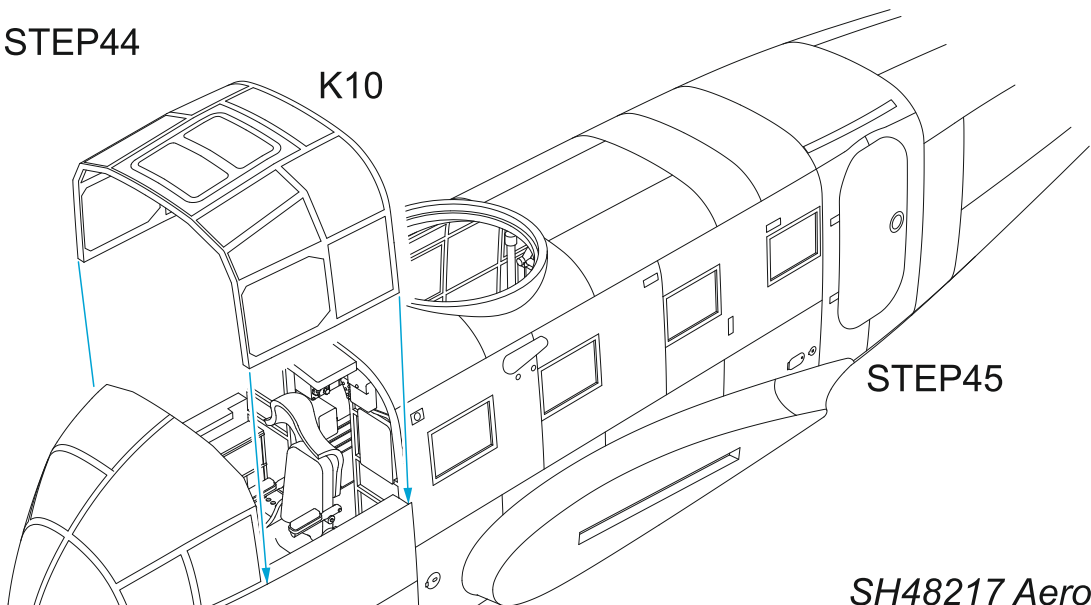

STEP 47

E C6/ B2 opposite

E E26/ E25 opposite

Dry fit first

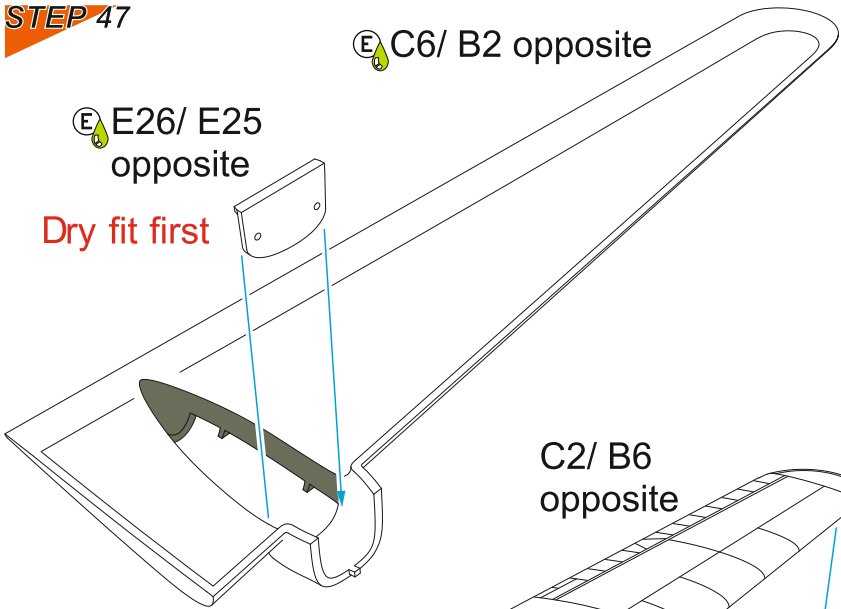

C2/ B6 opposite

STEP 49

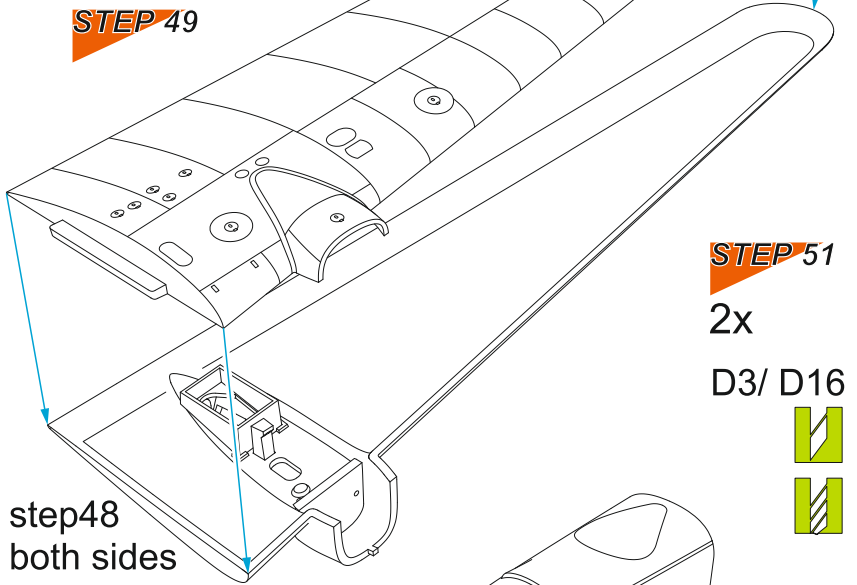

step48 both sides

STEP 51

2x

D3/ D16



STEP 53

2x

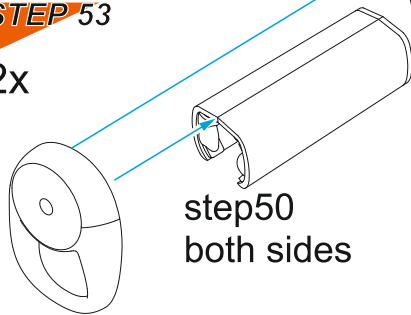

step50 both sides

step51 both sides

STEP 54

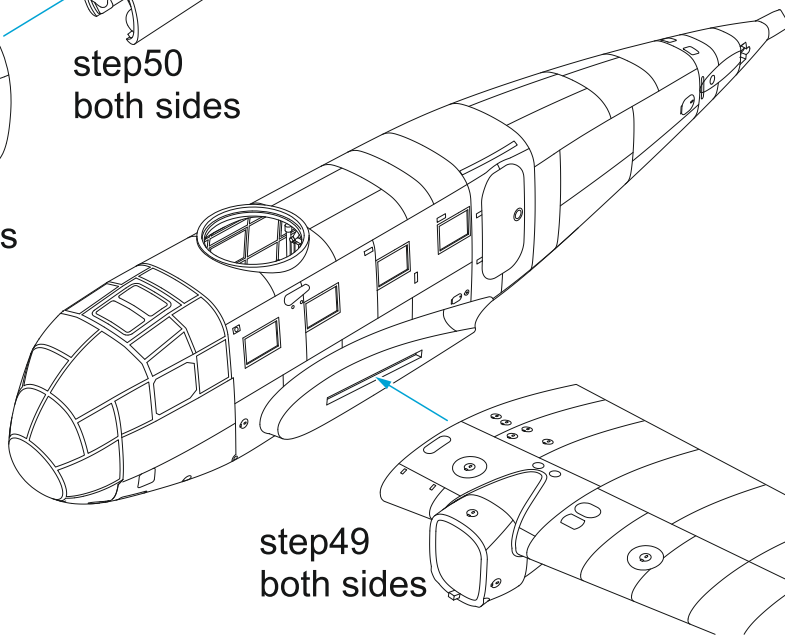

step49 both sides

STEP 48

E18/ E16 opposite E

E1/ E2 opposite

E19/ E15 opposite

E E5/ E30 opposite

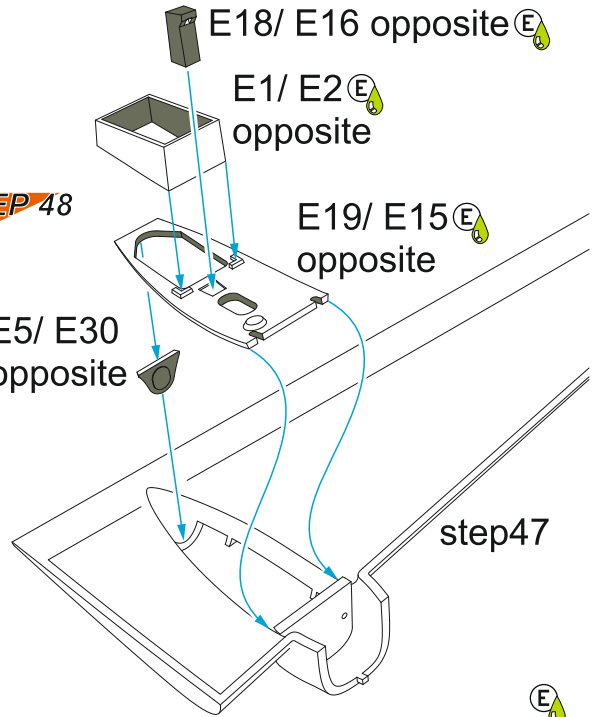

step47

STEP 50

F23/ F24

F25/ F26

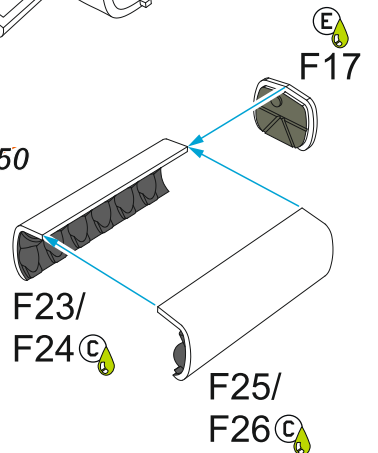

STEP 52

D8/ D11

D9/ D10

F D1/ D2

F D17/ D18

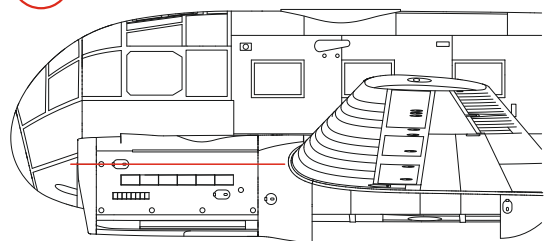
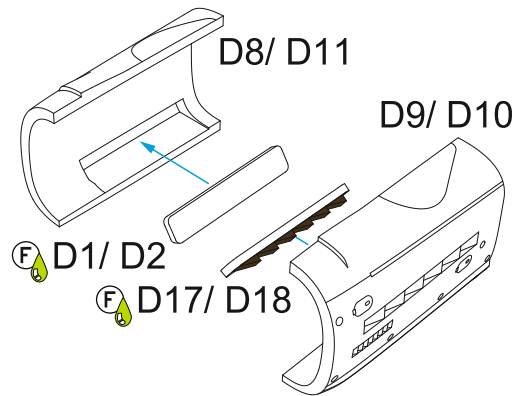

STEP 55

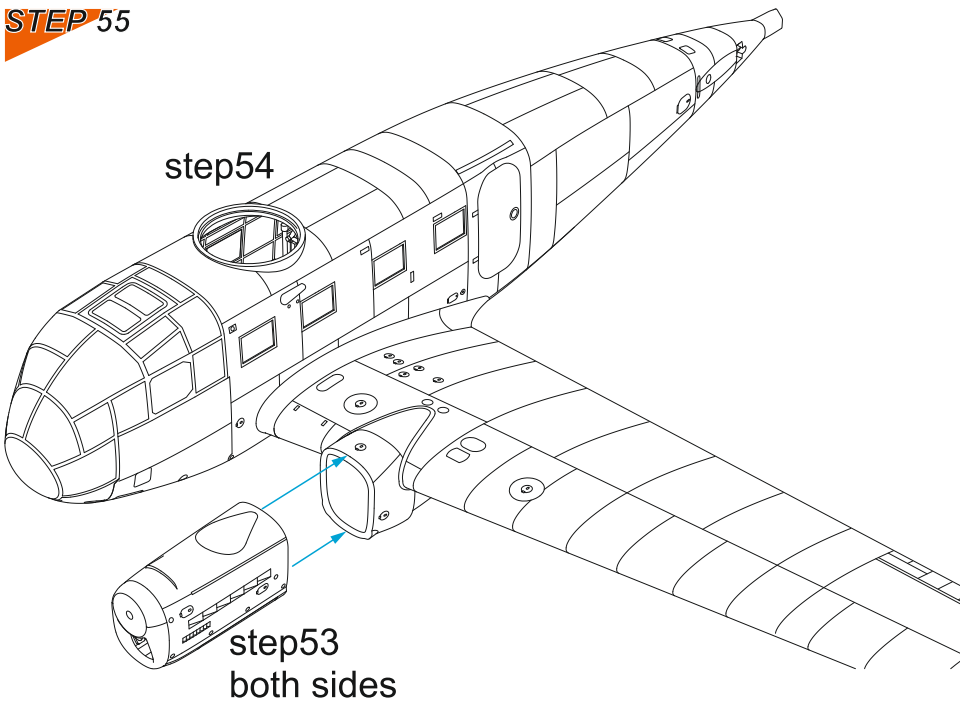

STEP 56

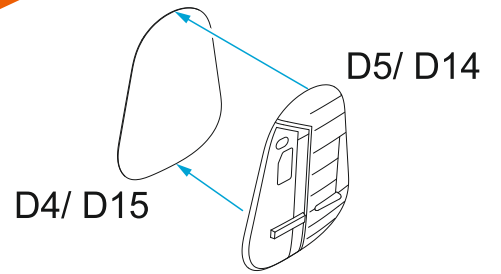

STEP 57

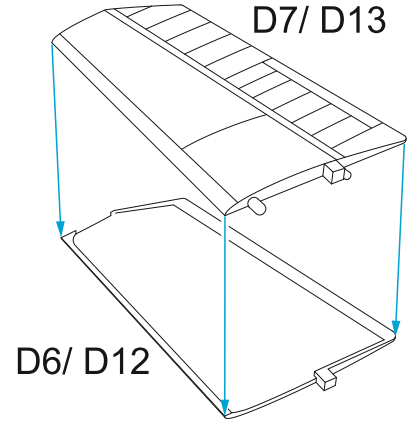

STEP 58

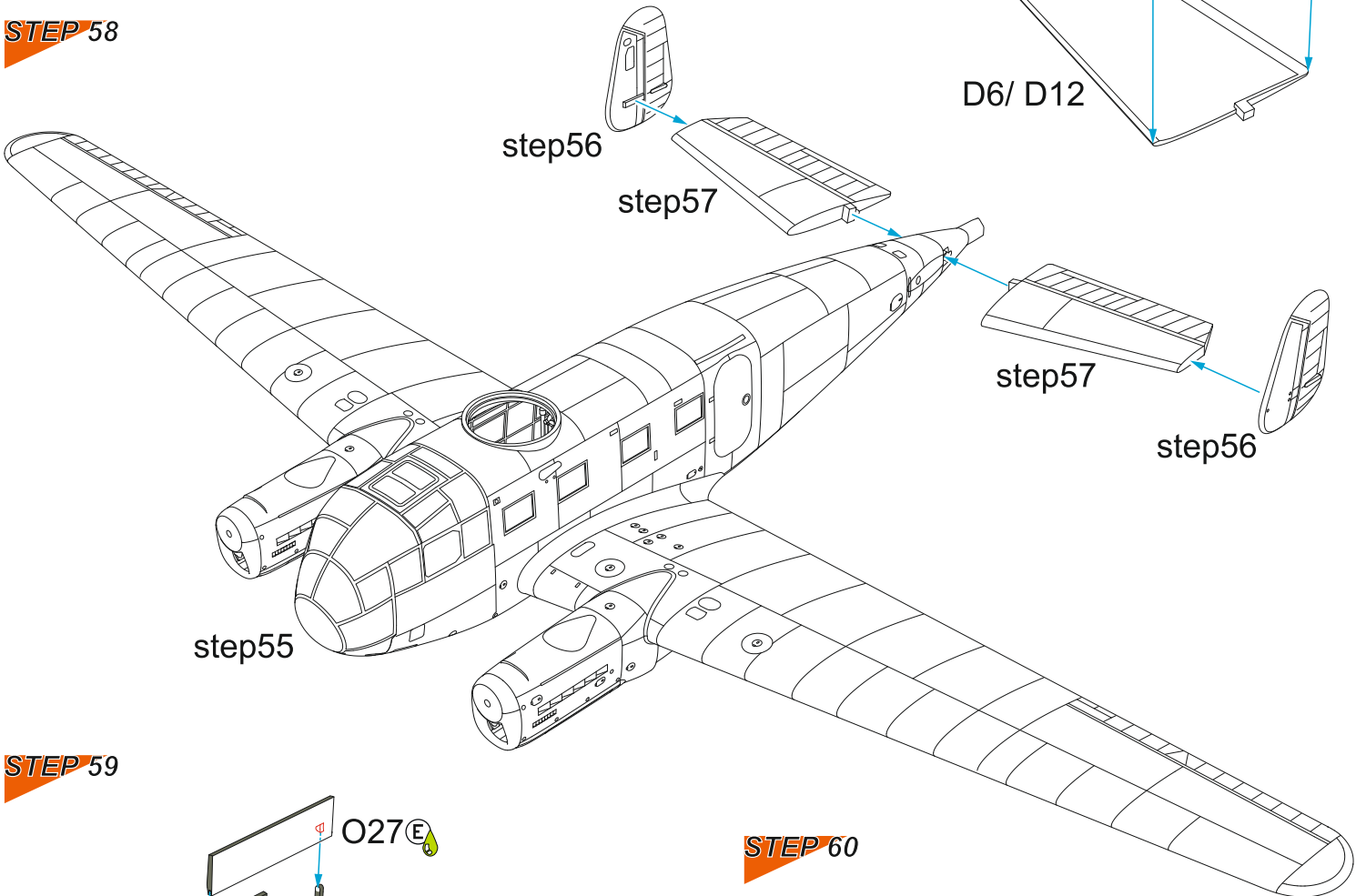

STEP 59

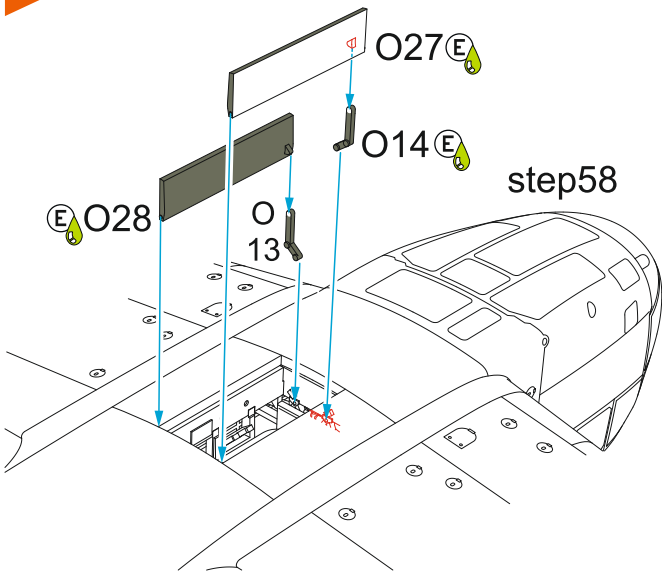

STEP 60

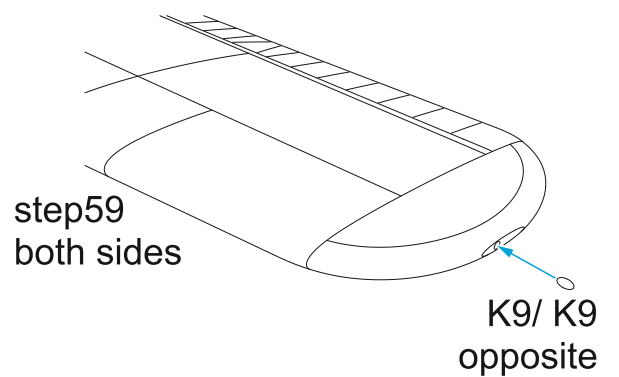

STEP 61

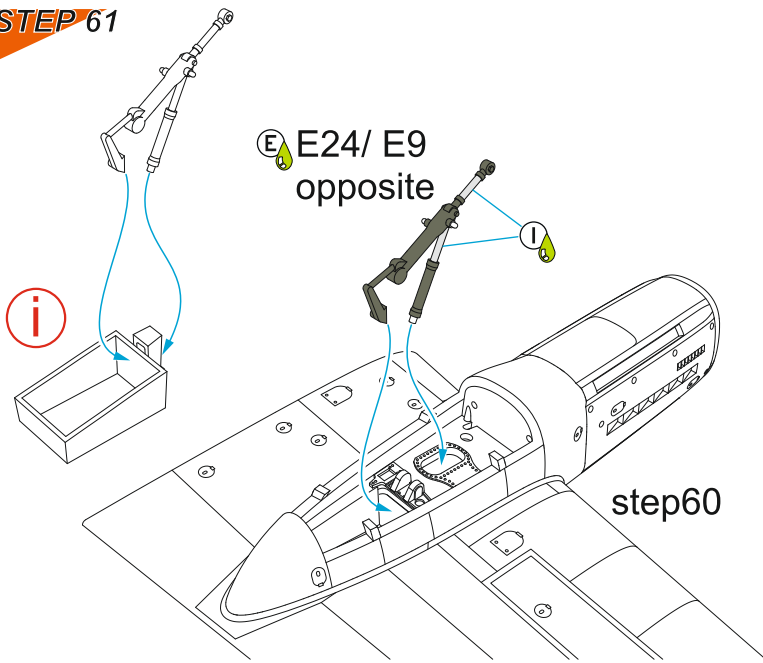

STEP 62

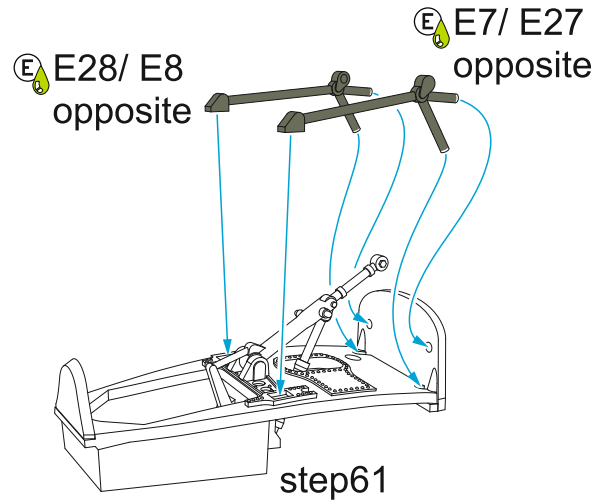

STEP 63

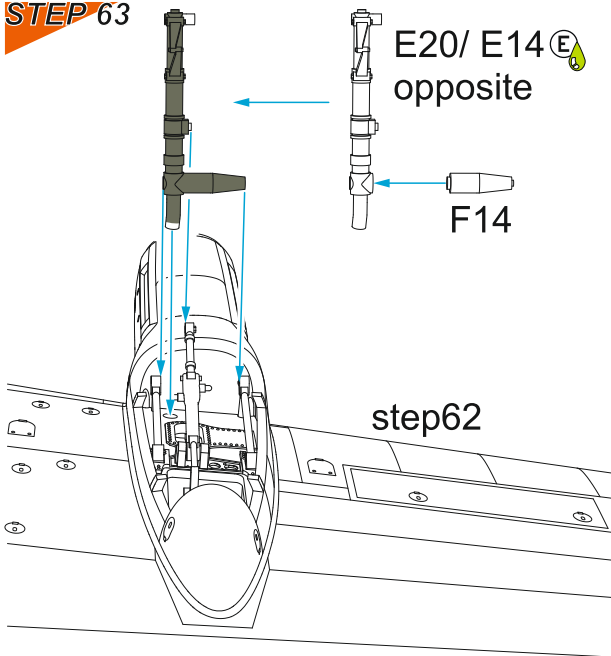

STEP 64

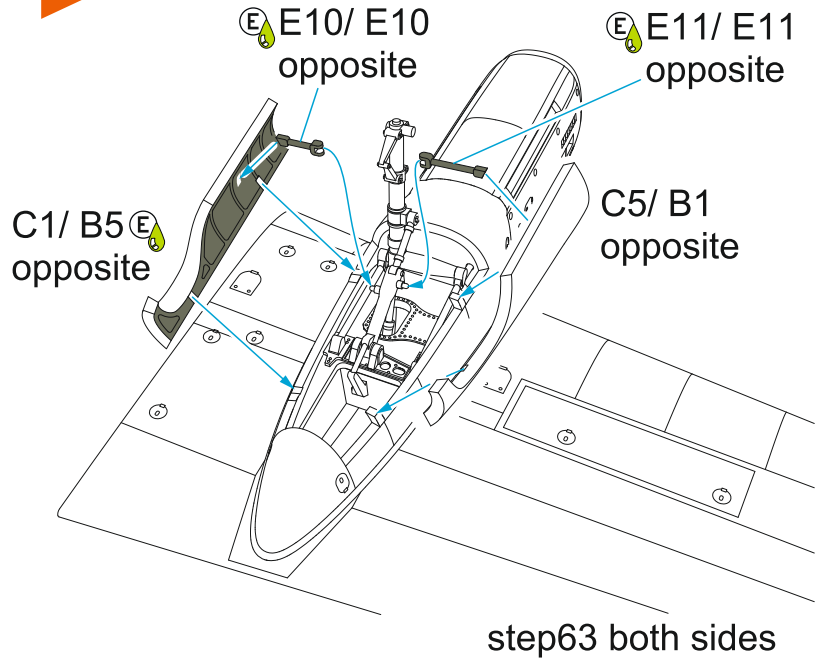

STEP 65

STEP 66

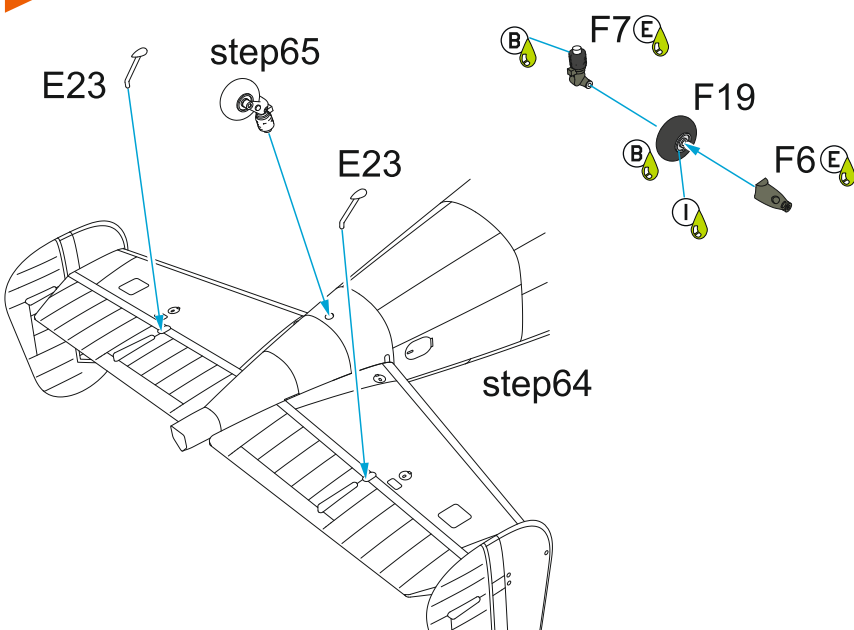

STEP 67

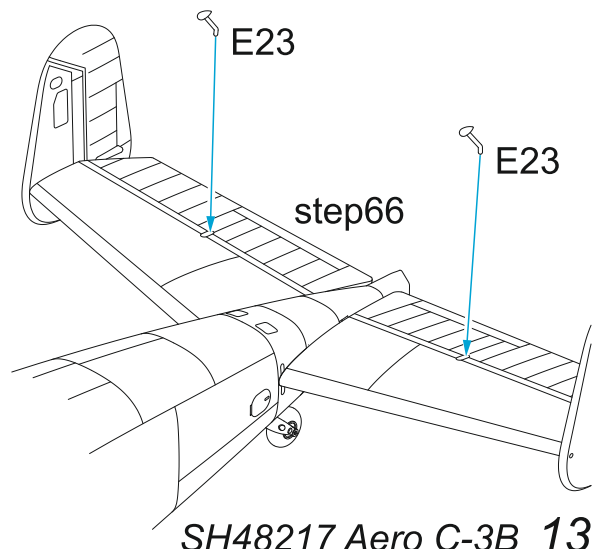

STEP 68

2x

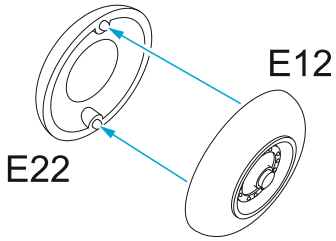

STEP 69

step67

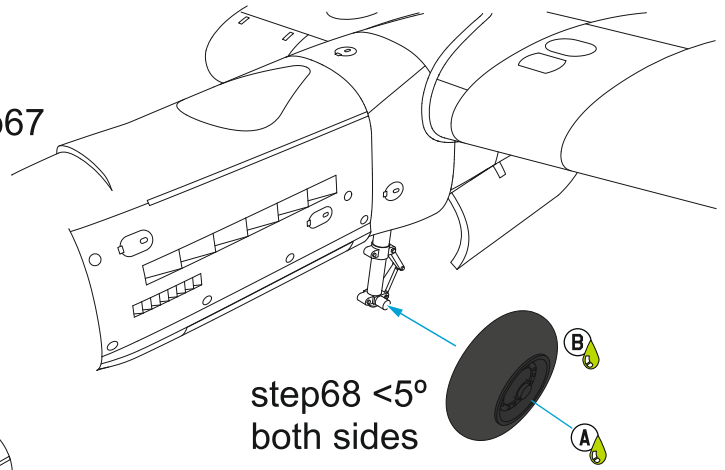

STEP 70

step69
both sides

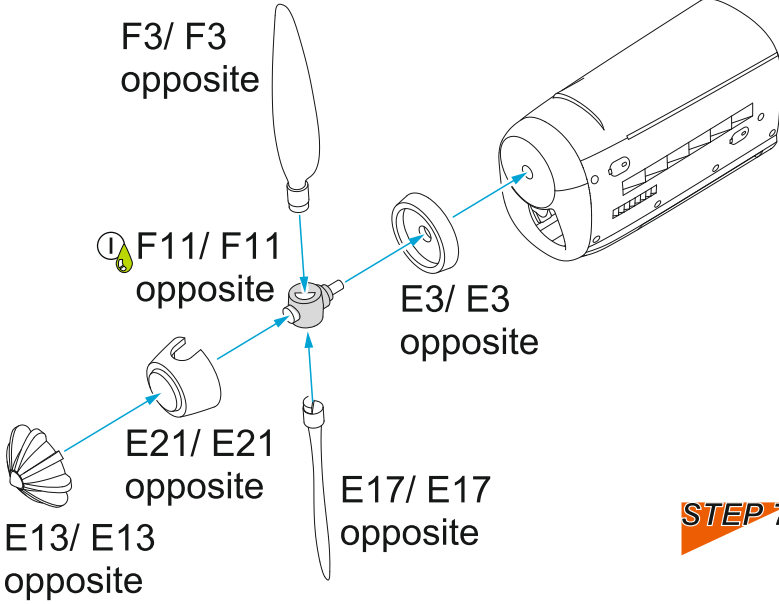

Scheme A, C - STEP 71 to STEP 80

STEP 71

STEP 72

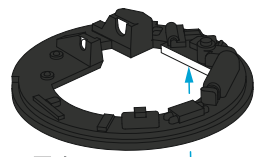
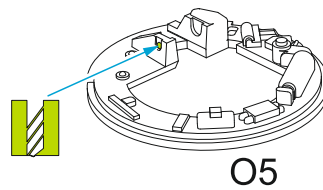

step71

M23

STEP 73

M20

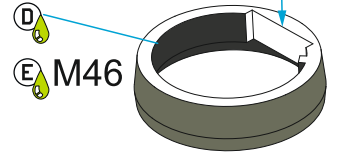

STEP 74

STEP 75

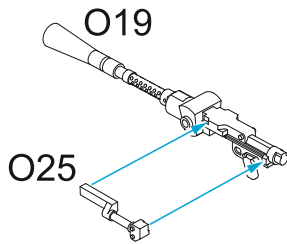
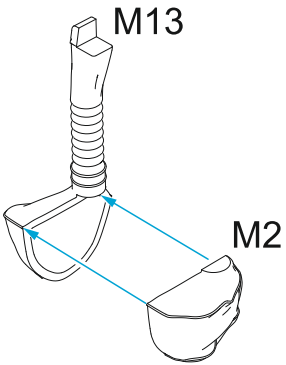

step72

STEP 78

M18

step77

STEP 76

STEP 77

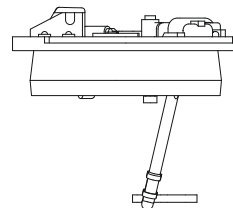
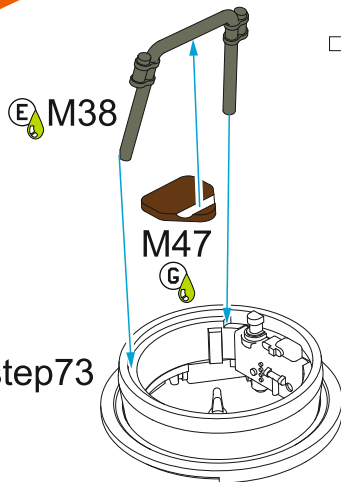
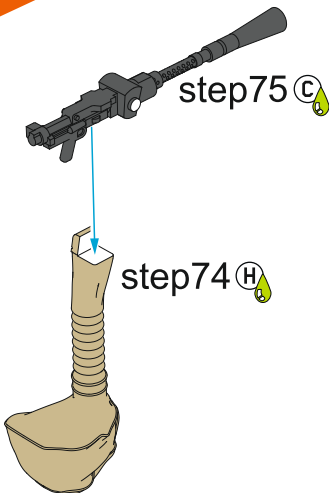

step76



STEP 79

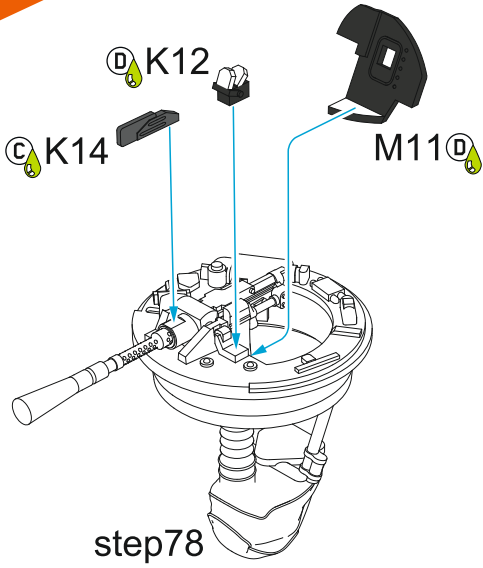

STEP 80

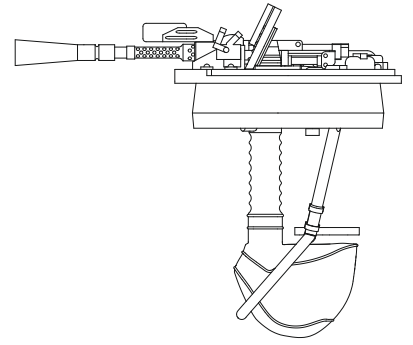
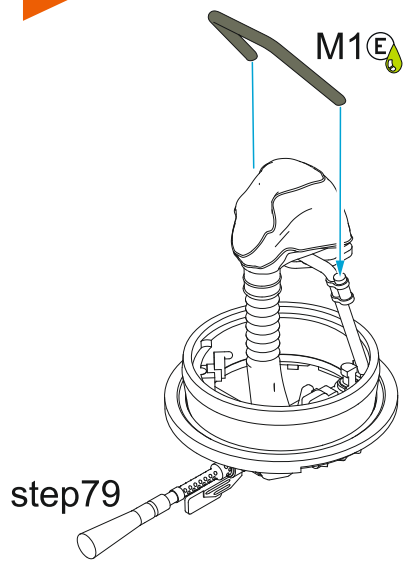

STEP 81

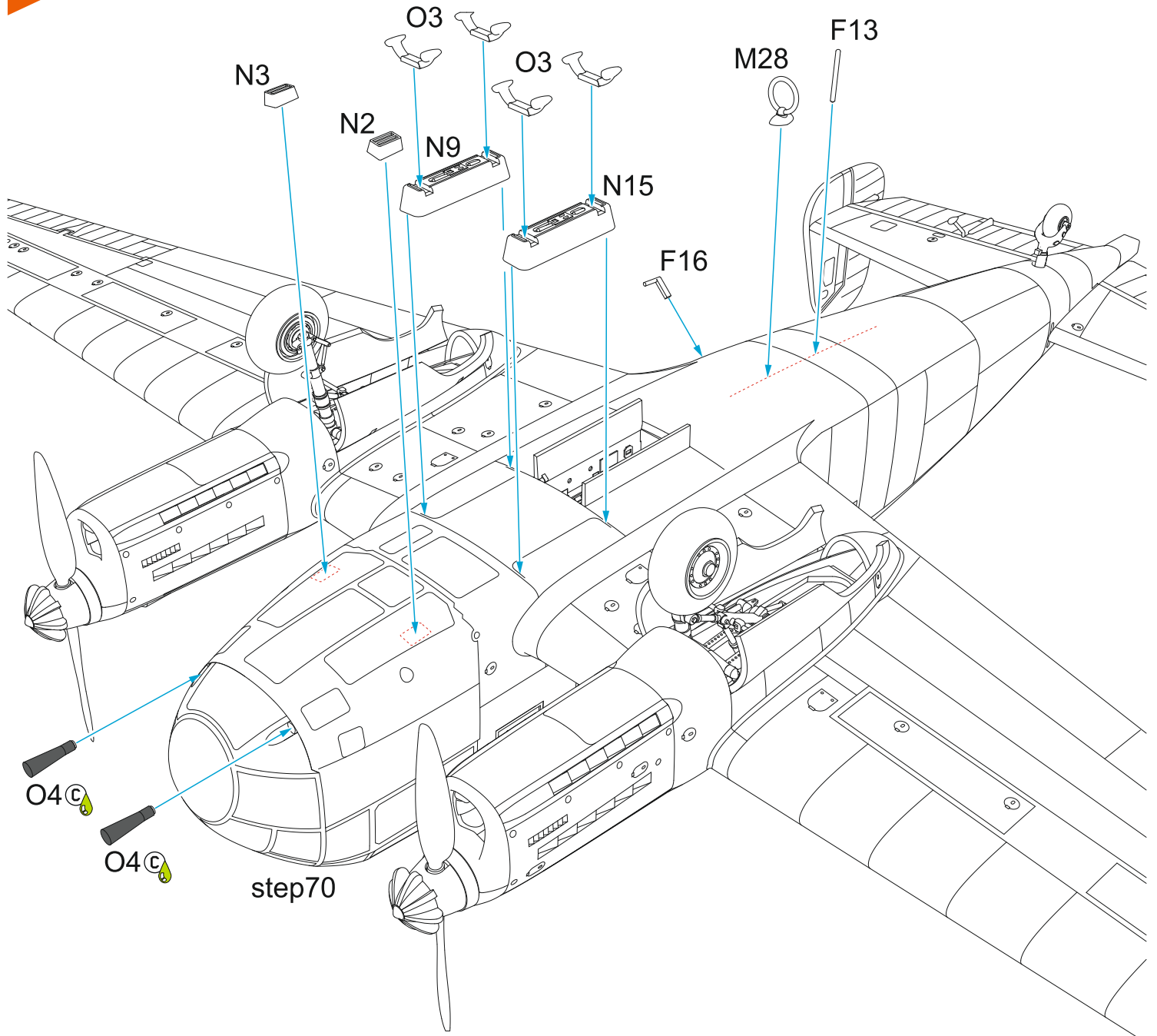

STEP 82

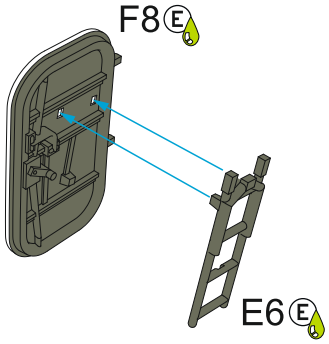

STEP 83

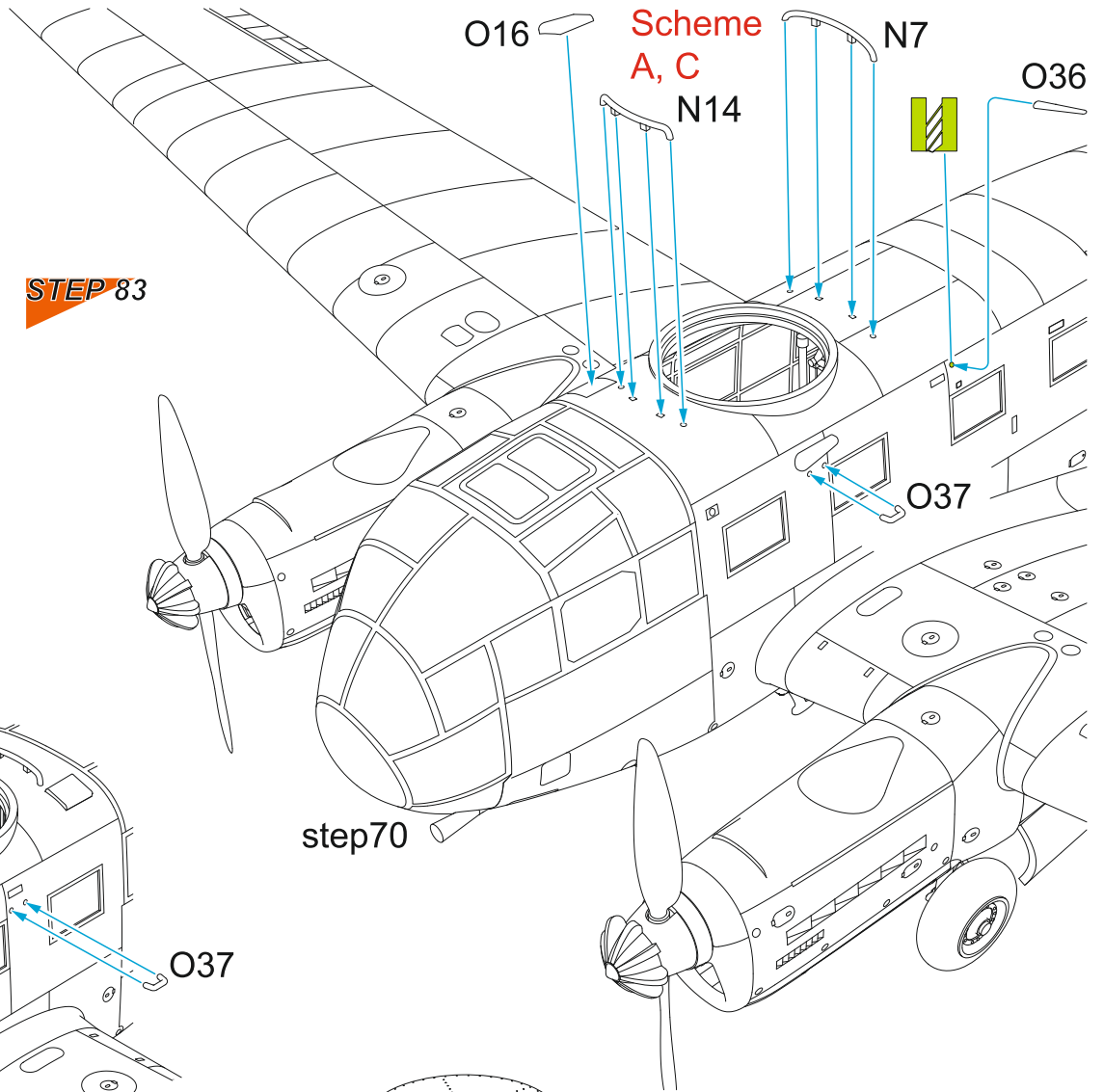

STEP 84

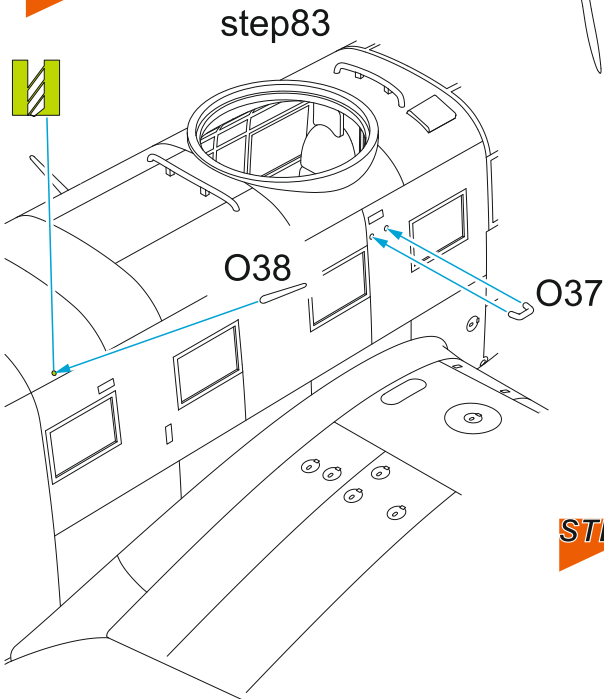

step70

STEP 85

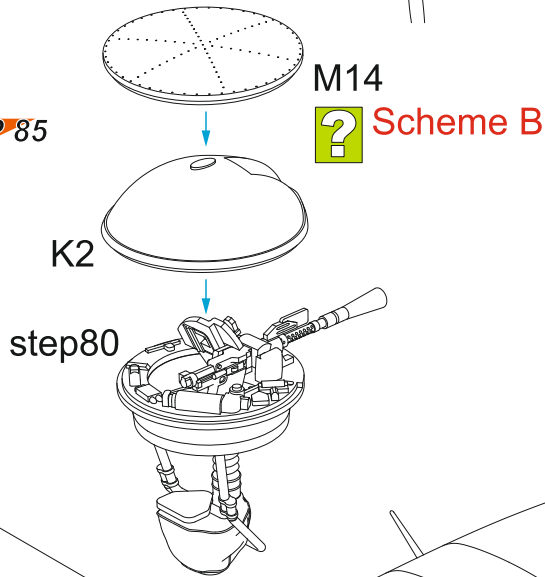

step84

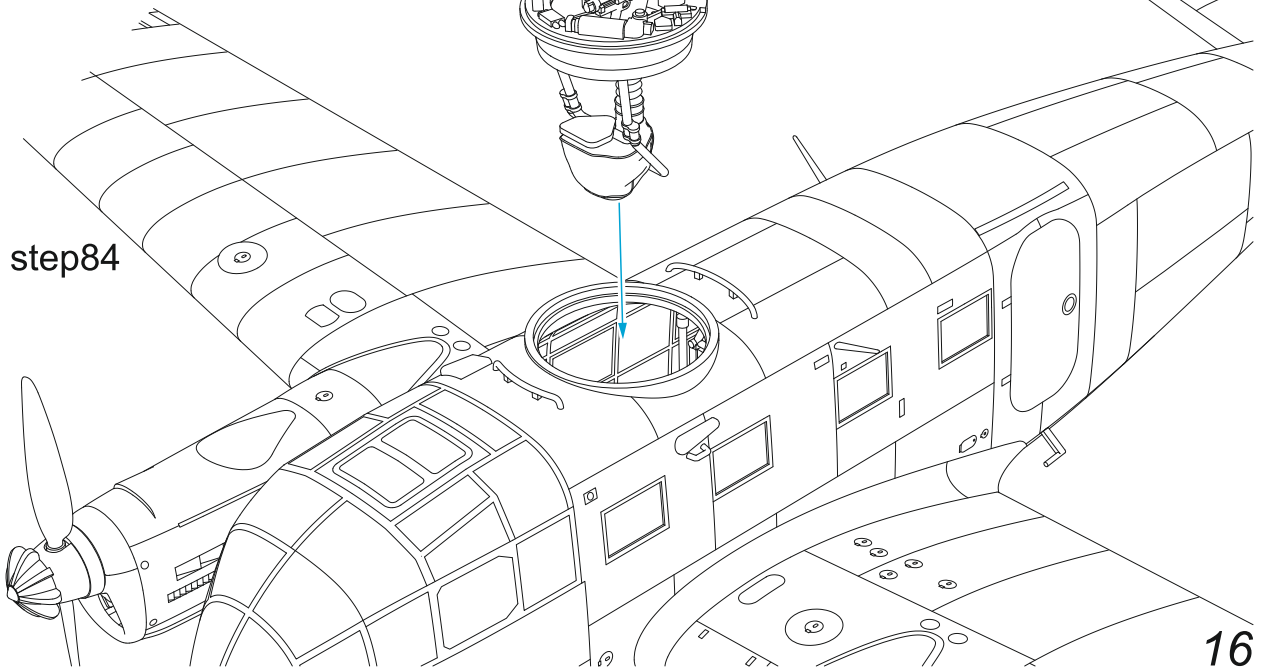

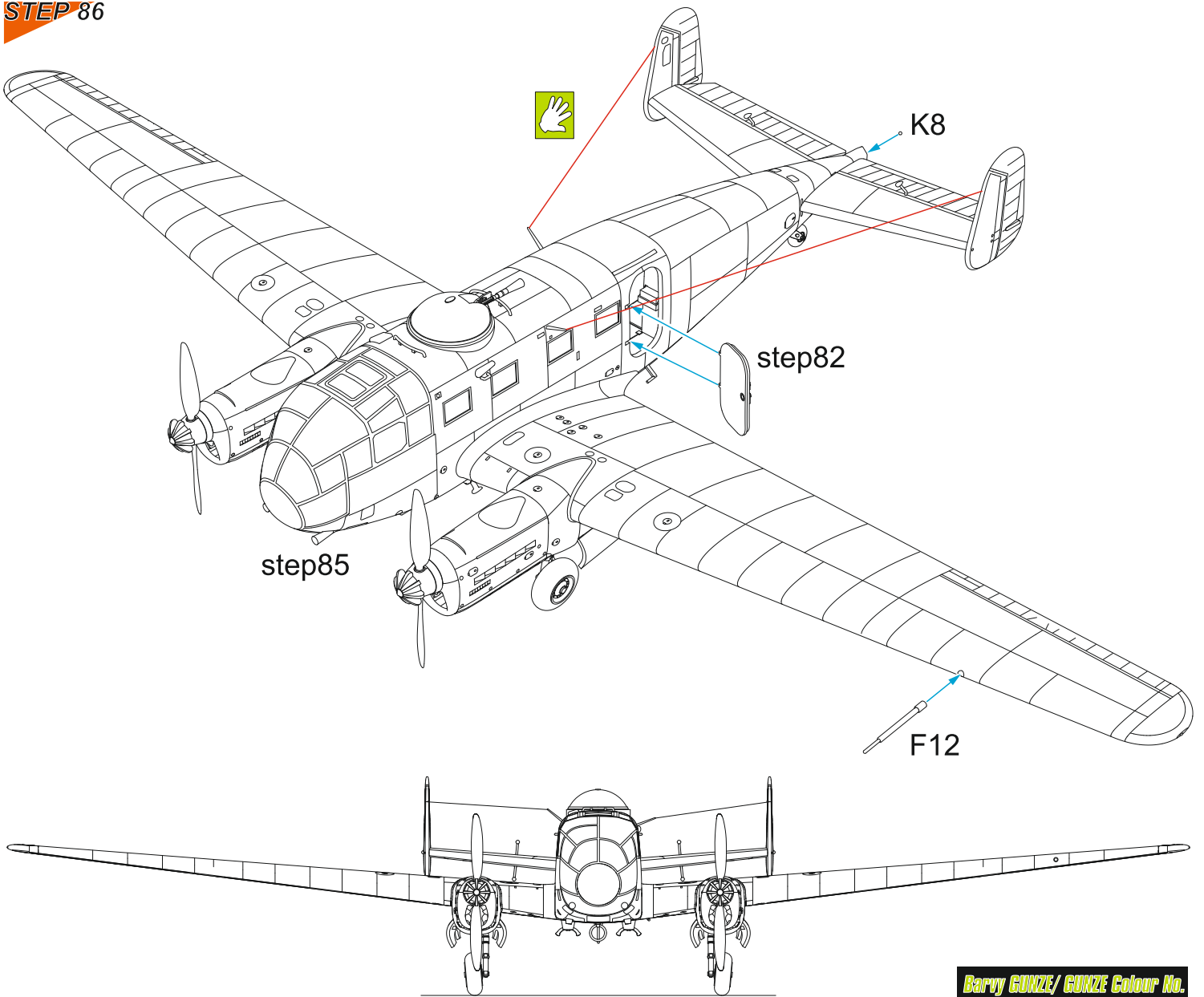

Barry GUNZE / GUNZE Colour No.

A Černá/ Black	H12/ C33	E Šedá 02/ Grey 02	H70/ C60	I Hliníková/ Aluminium	H8/ C8
B Barva pneu/ Tire Black	H77/ C137	F Opálený kov/ Burnt Iron	H76/ C61	J Mosaz/ Brass	MC219
C Tmavý kov/ Gun Metal	H28/ C78	G Barva kůže/ Leather	H17/ C29	K Tm. zelená 71/ D. Green 71	H64/ C17
D Černošedá 66/ Black Grey 66	C116	H Pískově žlutá/ Sand Yellow	H66/ C119	L Červená/ Red	H3/ C3

SYMBOLS

MOŽNOST VOLBY OPTIONAL NACH BELIEBEN OPTION	POUŽIT KYANOAKRYLÁTOVÉ LEPIDLO INSTANT CYANOACRYLATE GLUE ZYANOAKRYLATKLEBER COLLE CYANOACRYLAT	OHNOUT BEND BIEGEN COURBER	ZHOTOVIT NOVÉ SCRATCH BUILD FERTIGSTELLEN ACHEVER	ŘEZAT/VRTAT CUT OFF/DRILL ENTFERNEN DETACHER	GSI A colour code	NATŘÍT COLOUR FARBEN PEINDRE
--	--	-------------------------------------	--	---	-----------------------------	---------------------------------------

1/48 CMK sets for Siebel Si 204/Aero C-3

 F48357 Mechanic (Engine Repair)	 F48358 Airman (Cleaning Canopy Glazing)	 F48359 Rigger (Prop Maintenance)	 F48367 Luftwaffe WW2 / CS Post-War Aircraft Mechanic	 Q48352 Wheels	 Q48353 Pilots' Seats	 4386 Engine
				 Q48354 Prop Spinners	 4415 German WWII Aircraft Maintenance Toolbox	

Aero C-3B, V-15, vyr. číslo 401, Vědecký letecký ústav, Letňany, 1947. V březnu 1947 tento letoun operoval z letiště Malacky – Nový Dvůr. Zúčastnil se bombardování ledových bariér, které zatarasily říční koryto na Dunaji pod Bratislavou. Úspěšná akce tehdy zachránila Bratislavu před katastrofálními povodněmi. Letoun V-15 pilotoval major Jiří Maňák, DFC, vynikající československý stíhací a útočný pilot. Za války mimo jiné velel No.198 Sqn. RAF, operující na Typhoonech.

Aero C-3B, V-15, c/n 401, Aeronautical Research Centre, Letnany, 1947. In March 1947, this aeroplane was being operated from Malacky – Novy Dvor airfield to take part in the bombing of ice barriers blocking the River Danube running through Bratislava, saving the city from catastrophic floods. Aircraft V-15 was flown by Maj. Jiri Manak, DFC, an excellent Czechoslovak fighter and attack pilot who had been the CO of Typhoon-equipped No. 198 sqn RAF during the war.

Camo A

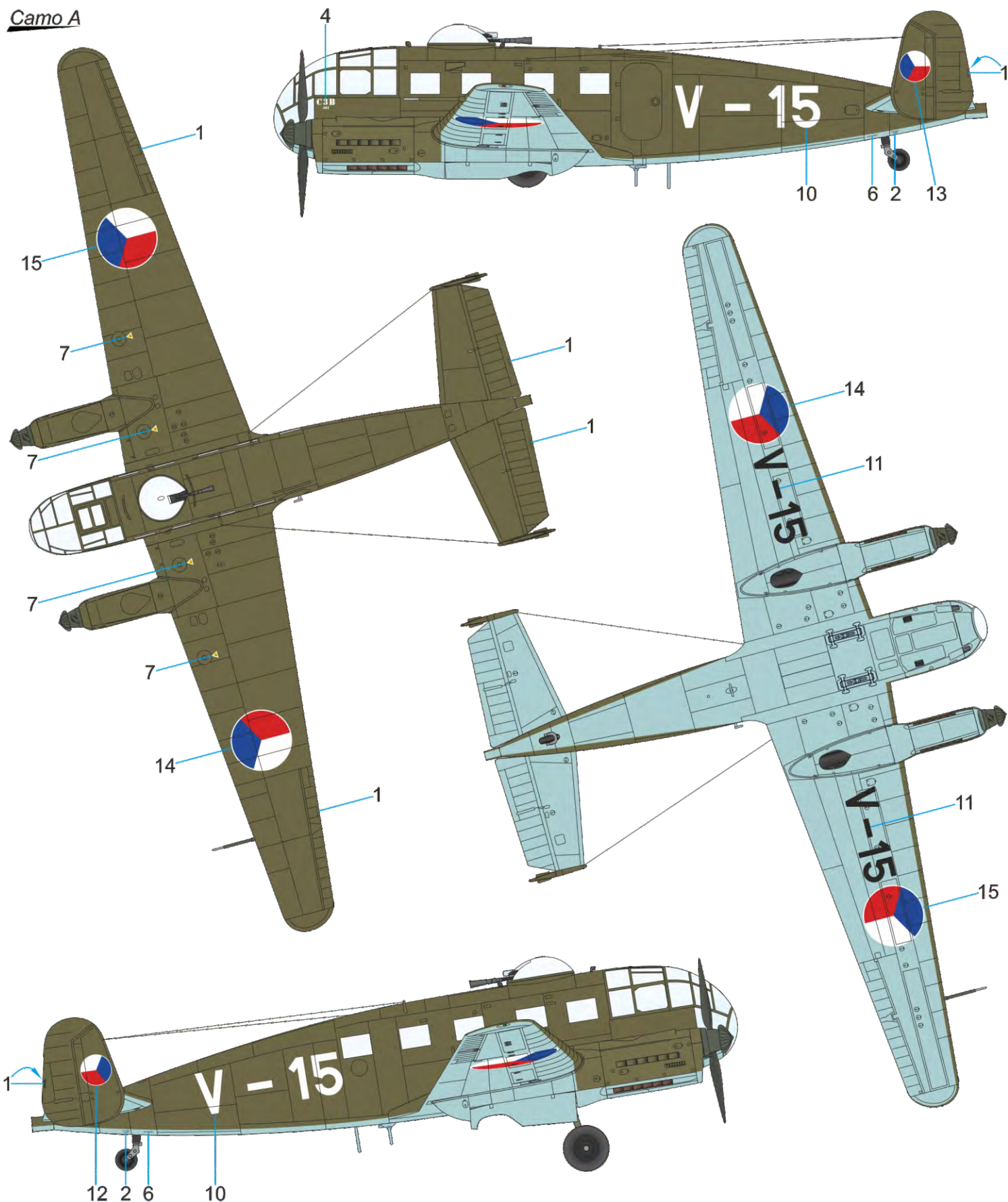

Black Green
Schwarzgrün
Černozelená
H65/C18/RLM70

Green Khaki
MNO 2036
Small Khaki Avion
H303/C303

Light Blue
Hellblau
Světle modrá
H67/C115/RLM65



Aero C-3B, A-360, výr. číslo 413, 3. výcviková letka, výcviková perut LVA, Hradec Králové, 1947. A-360 neměl prosklenou střeleckou věž, základna věže byla zaplechována. I tento letoun byl v březnu 1947 přesunut na letiště Malacky – Nový Dvůr a zúčastnil se bombardování ledových bariér. Při tom jej nejčastěji pilotoval šéft let. Rudolf Haering, DFM. Tento bývalý pilot Wellingtonů a Liberatorů No.311 Sqn. RAF měl, podobně jako J. Maňák, těžký osud po komunistickém převratu v únoru 1948. Oba byli vězněni a po propuštění mohli pracovat jen v manuálních profesích.

Aero C-3B, A-360, c/n 413, 3rd Training Flight, Training Squadron of the Air Force Academy, Hradec Kralove, 1947. Aeroplane A-360 was not fitted with the glazed gun turret, the base of which was only covered with sheet metal. A-360 was also redeployed to Malacky – Novy Dvor to battle the ice barriers, in which missions it was most often flown by Staff Capt. Rudolf Haering, DFM, a pilot who had during the war years flown Wellingtons and Liberators of No.311 sqn RAF. Both Haering and Manak had particularly tough fates in Czechoslovakia following the February 1948 communist coup, were imprisoned and when eventually released, were only allowed manual jobs.

Camo B

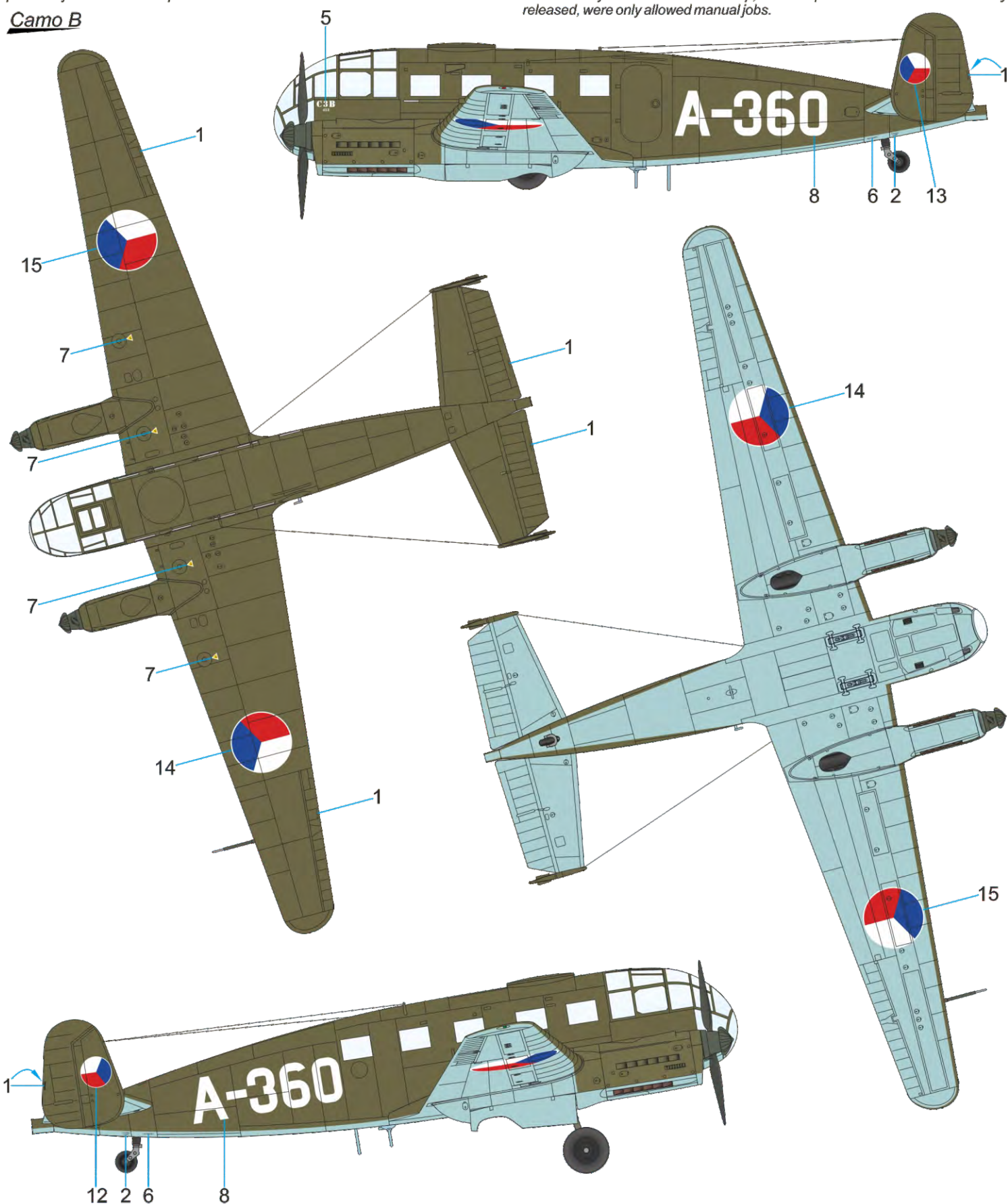

Black Green
Schwarzgrün
Černozelená
H65/C18/RLM70



Green Khaki
MNO 2036
Smalt Khaki Avion
H303/C303



Light Blue
Hellblau
Světle modrá
H67/C115/RLM65



Aero C-3B, PU-18, 1. letka, Letecký pluk 41 'T.G. Masaryk', Boží Dar – Milovice, jaro 1949. V roce 1950 byl pluk přechíslován na LP 47 a čestné pojmenování, upomínající prvního československého presidenta, bylo komunistickým velením armády zrušeno.

Aero C-3B, PU-18, 1st Flight, No. 41 'T.G. Masaryk' Air Regiment, Bozi Dar – Milovice, Spring 1949. In 1950 the regiment was renumbered LP 47 and its honorary title removed by the communist-led army command to no longer commemorate Tomas Garrigue Masaryk, the first president of independent Czechoslovakia.

Camo C

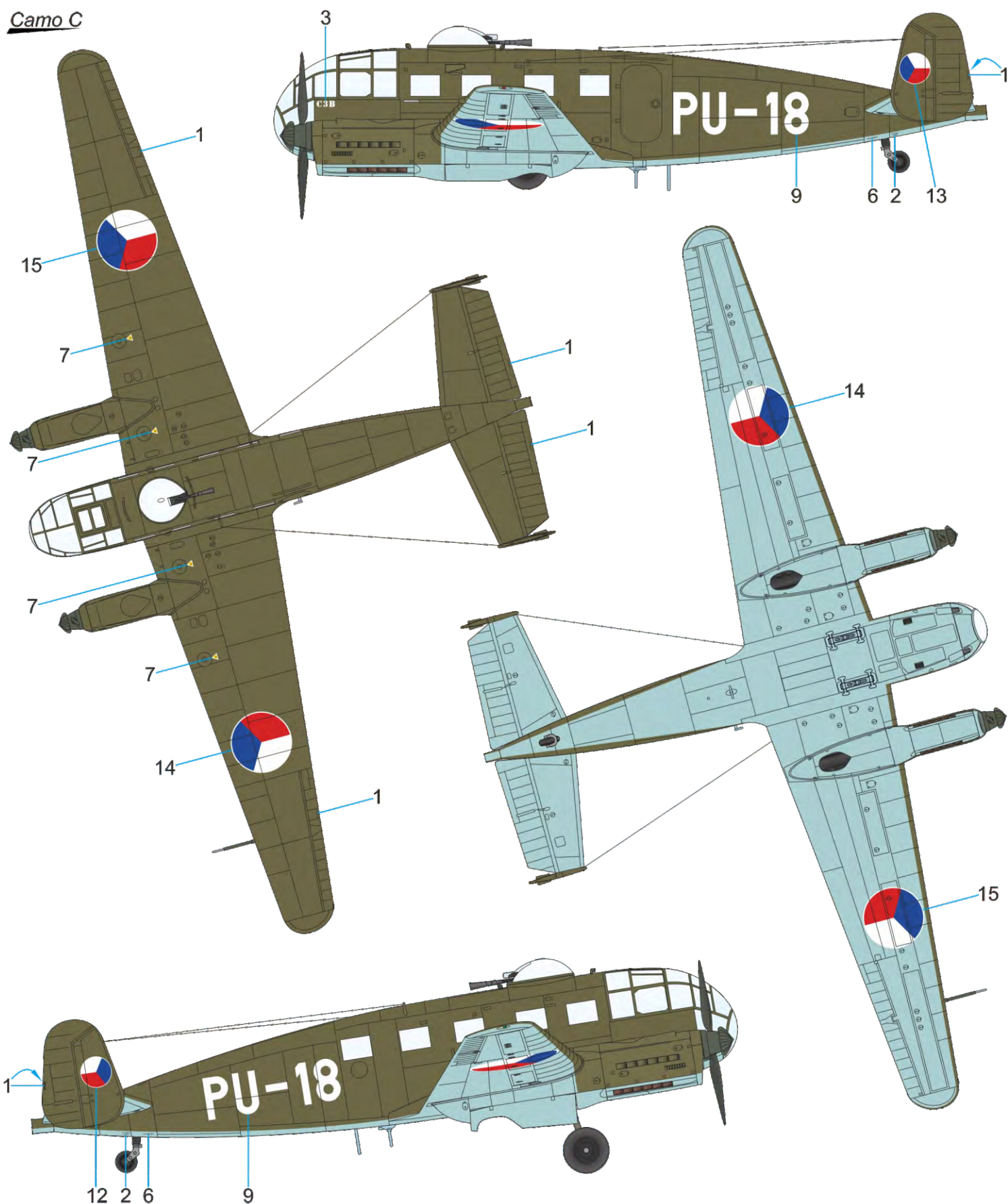

Black Green
Schwarzgrün
Černozelená
H65/C18/RLM70



Green Khaki
MNO 2036
Smalt Khaki Avion
H303/C303



Light Blue
Hellblau
Světle modrá
H67/C115/RLM65

