

SN72001

U-BOOT TYP XXIII

1/72

GB

U-Boot type XXIII

In 1944 the Kriegsmarine's submarines were in serious crisis. The sporadic successes were redeemed by serious losses. The answer to the Allied anti-submarine actions was partly the mounting of the Radar device and Schnorchels on current submarine types but also development of the new submarine types. Except the experimental types the development was focused on oceanic type XXI and coastal type XXIII. Unlike the XXI the XXIII was used operationally and it has several combat successes. Only one of 118 deployed type XXI submarines went on the combat mission but prior to the end of the war it didn't record any score.

Type XXIII submarines were produced in Deutsche Werft in Hamburg and Germania Werft in Kiel. Even that the production fell behind thanks to Allied bombardment still 59 submarines were completed and handed over. At the end of the war another 38 submarines type XXIII were in a state of deliver. The biggest problem at the end of the war was the crew training. Six type XXIII submarines set sail onto combat mission. The first one was U 2324 with commander Lt. Von Rapprad cleared the harbour on January 29th, 1945 (6 months after hand over to Kriegsmarine). It unsuccessfully shot two torpedoes in the Firth of Forth bay on the Allied convoy on February 18th 1945. U 2322 under command of 1st Lt. Heckel put out on February 6th and U 2321 under command of 1st Lt. Barschkis put out on February 12th. On February 25th the U 2322 sank British Egholm ship. On the next mission the U 2324 sank Monarch ship on April 16th and the U 2329 (1st Lt. Schlott) damaged Norwegian Sverre Helmersen ship on April 23rd. U 2336 under command of 1st Lt. Klusmeier put out from Kristiansand on May 1st 1945. It hadn't catch the order to terminate all combat actions from May 4th and sank Norwegian Sneland I and British Avondale Park ships in Firth of Forth bay on May 7th 1945. It came back to Kiel on May 14th. It was the last German submarine's victory in the Second World War. Another submarine, the U 2326 (1st Lt. Jobst) also hadn't catch the order to terminate all combat actions but till May 10th hadn't spot any prey and returned back. During the combat missions none type XXIII submarine was sunk by the Allies.

Technical data:

Displacement (Sfcd/Submerged in tons): 234/ 258, Dimensions: 34,7 x 3m, Armament: 2 torpedoes, Crew: 14.

CZ

U Boot typ XXIII

V roce 1944 se ponorky Kriegsmarine dostaly do vážné krize. Ojedinelé úspěchy byly vykoupeny vážnými ztrátami. Odpovědí na úspěchy protiponorkových opatření spojenců bylo jednak použití radaru a snorchelu na stávajících ponorkách, jednak vývoj nových typů ponorek. Mimo pokusných typů se vývoj soustředil na oceánský typ XXI a pobřežní typ XXIII. Na rozdíl od typu XXI se pobřežní typ XXIII dočkal nasazení a může se pochlubit i bojovými úspěchy (na bojovou plavbu vyplula pouze jedna ponorka typu XXI ze 118 převzatých kusů, ale před ukončením bojů nedosáhla úspěchu).

Výroba ponorek typ XXIII probíhala v loděnicích Deutsche Werft v Hamburku a v Germania Werft v Kielu. Výroba se opožďovala, hlavně díky bombardování, přesto se podařilo postavit a předat 59 kusů a v době ukončení války bylo v fázi předávání dalších 38 kusů ponorek typ XXIII. Největším problémem byl ale na konci války výcvik posádek. Na bojové plavby se vydalo 6 ponorek typu XXIII. Jako první vyplula U 2324 pod velením kapitán poručíka von Rapprada 29.1. 1945 (6 měsíců po předání Kriegsmarine). V operační oblasti zálivu Firth of Forth odpálila 18.2. 1945 bezúspěšně obě torpéda na spojenecký konvoj. 6.2. 1945 vyplula U 2322 (npor Heckel) a 12.2.1945 U 2321 (npor Barschkis). U 2322 potopila 25.2. 1945 britskou loď Egholm. U 2324 potopila při další plavbě 16.4. loď Monarch a U 2329 (npor. Schlott) poškodila 23.4. norskou loď Sverre Helmersen. 1.5.1945 vyplula z Kristiansandu ponorka U 2336 pod vedením npor. Klusmeiera. Nezachytila rozkaz k ukončení bojových akcí vydaný 4.5. 1945 a dne 7.5. 1945 potopila v zálivu Firth of Forth norskou Sneland I a britskou Avondale Park. Vrátila se 14.5. do Kielu. Šlo o poslední úspěch německé ponorky za druhé světové války. Další ponorka U 2326 (npor. Jobst), také nezachytila rozkaz k ukončení bojových operací, do 10.5.1945 však nenarazila na kořist a vrátila se zpět. Při bojových akcích nebyla spojenci potopena ani jedna ponorka typu XXIII.

Technická data:

Výtlak nad hladinou: 234 t, výtlak pod hladinou: 258 t, rozměry: 34,7 x 3 m, výzbroj: 2x torpeda, posádka: 14 mužů

PARTS - DÍLY

A

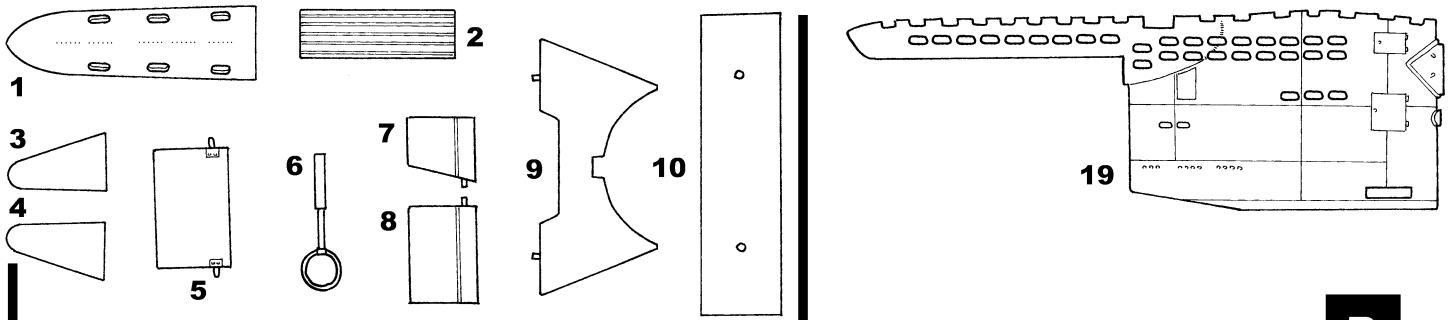
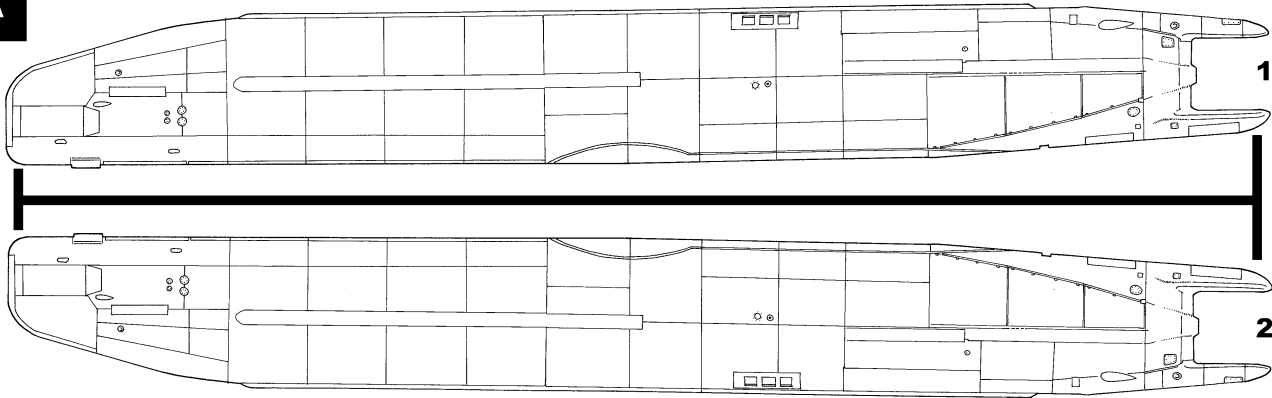

B

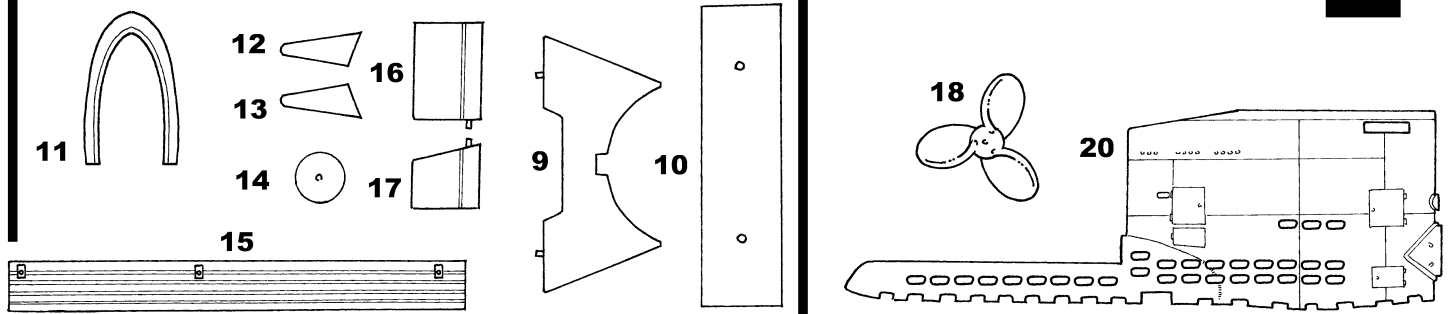

POLYURETHAN PARTS (PUR)



PHOTO-ETCHED PARTS (PP)

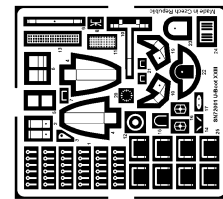
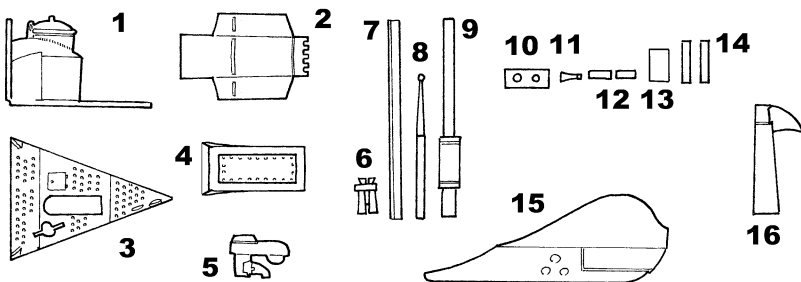

FILM (F)



Volba
Optional
Nach beliebigen
Option



Odstranit
Remove
Entfernen
Detacher



Lepidlo na kov
Glue for metal
Metallkleber
Cole a metal



Obtisk
Decal
Abziehbilder
Decalque



Barva
Color
Farben
Peindre



Clear fix



Hobby Color / Mr. Color

1/1 Bílá
White

10/10 Měď
Copper

37/43 Dřevo
Wood

21/69 Špinavě bílá
Off White

2/2 Černá
Black

325/325 Šedá
Grey

90/47 Červená
Red

8/8 Stříbrná
Silver

25/34 Modrá
Blue

301/301 Tmavě šedá
Dark Grey

ASSEMBLY - SESTAVA

1

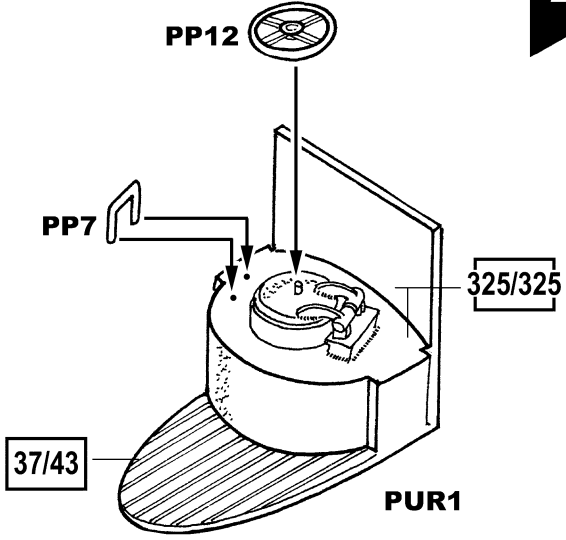

2

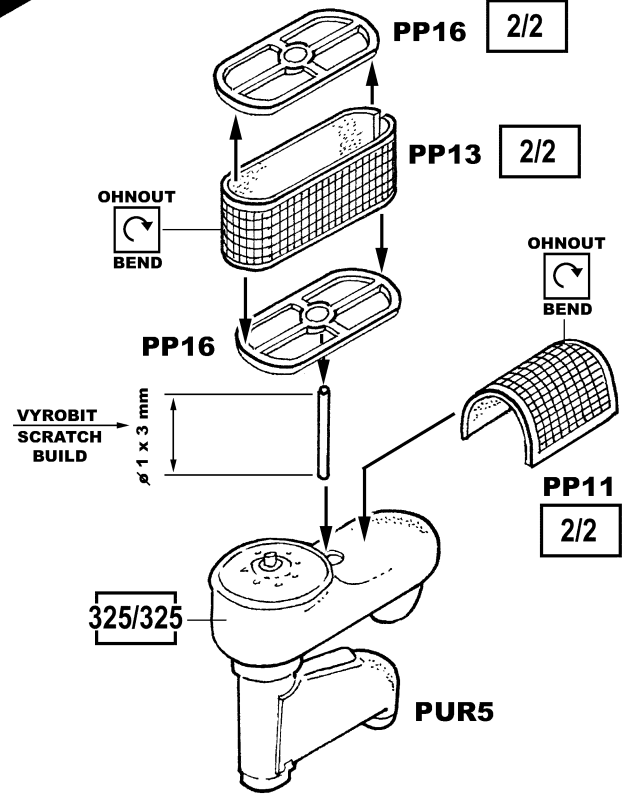

3

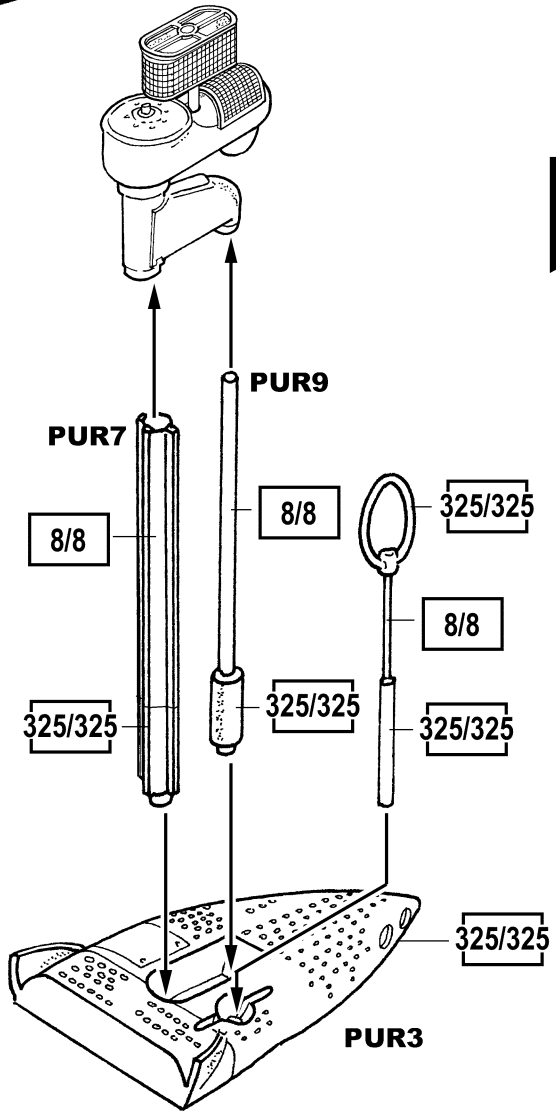

4

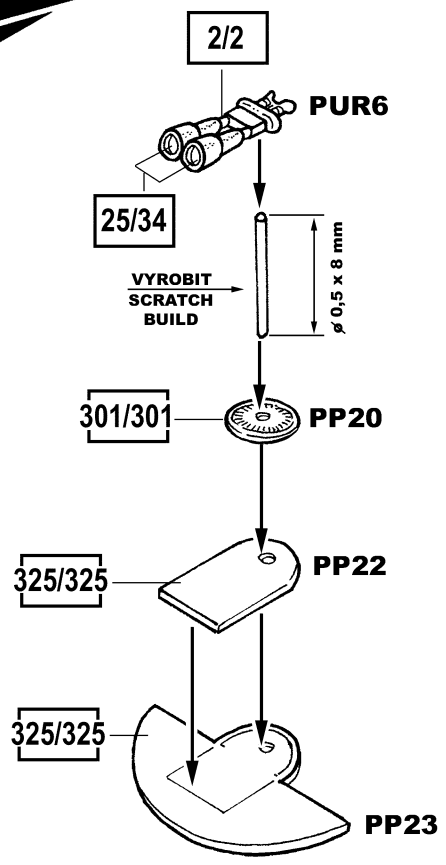

ASSEMBLY - SESTAVA

5

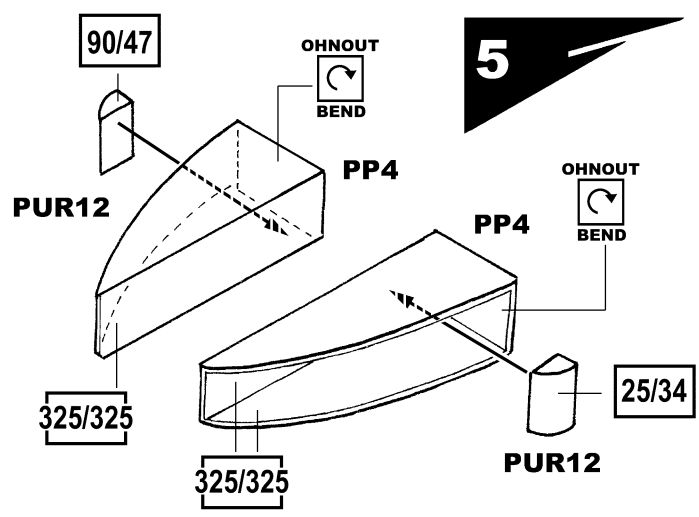

6

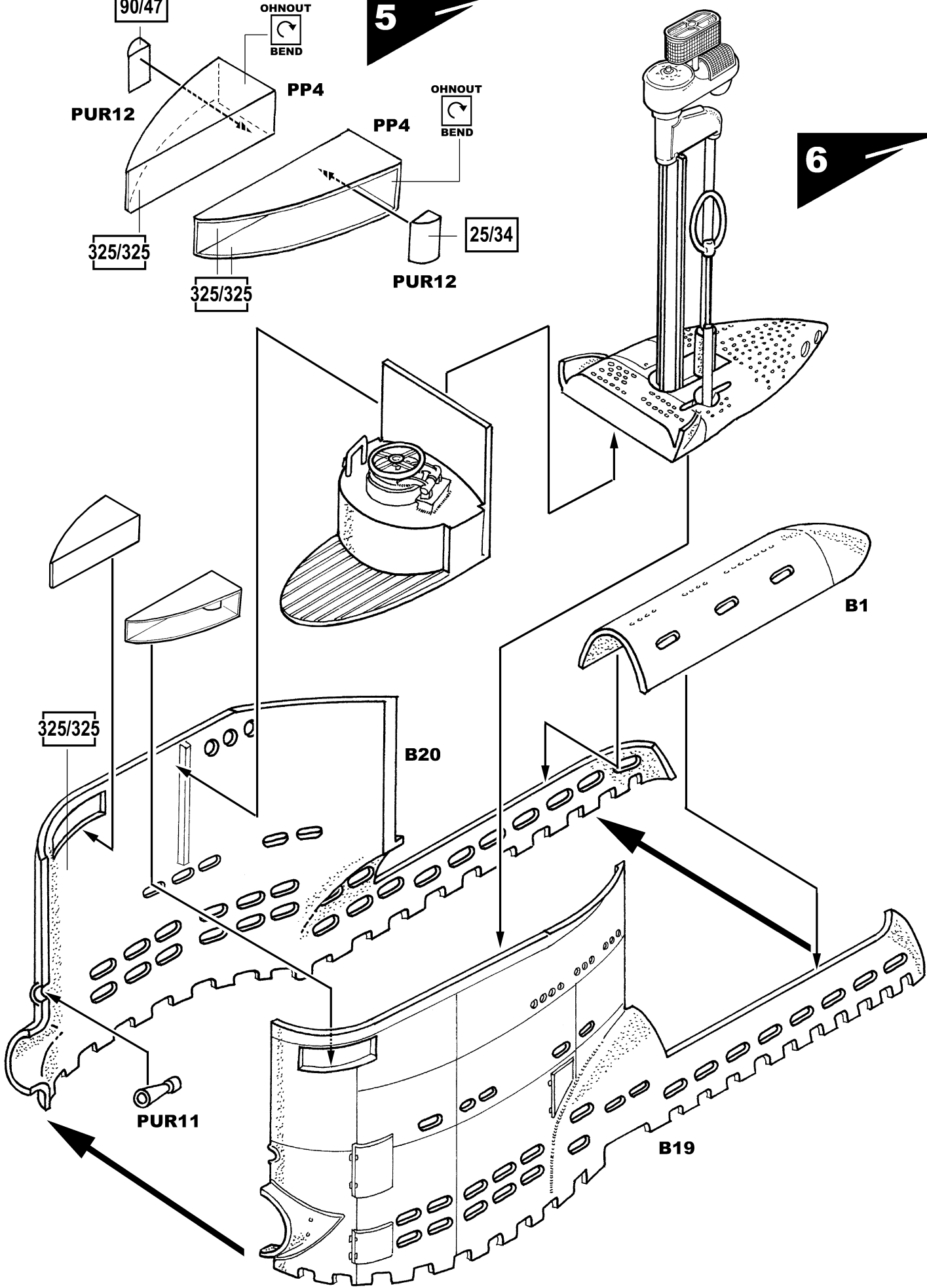

ASSEMBLY - SESTAVA

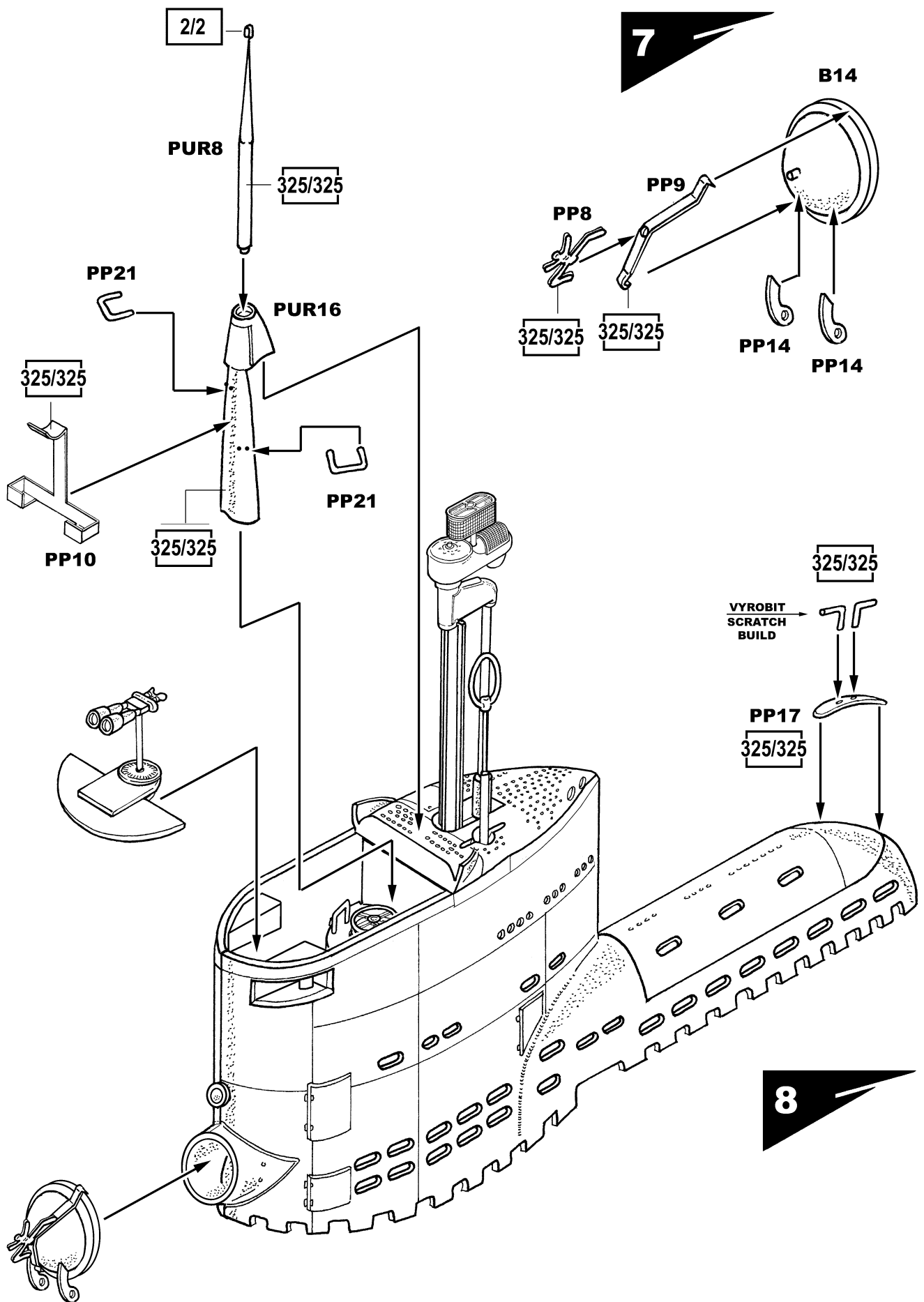

ASSEMBLY - SESTAVA

9

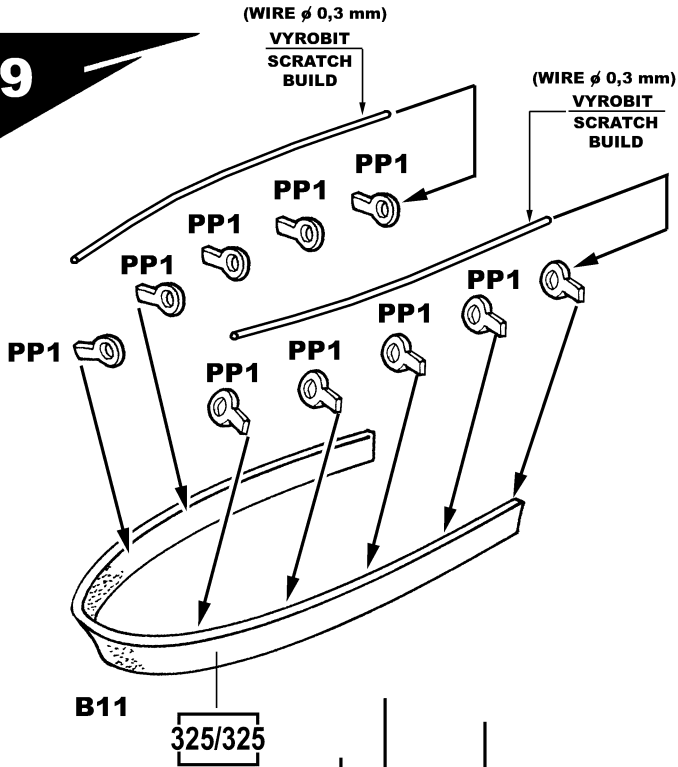

10

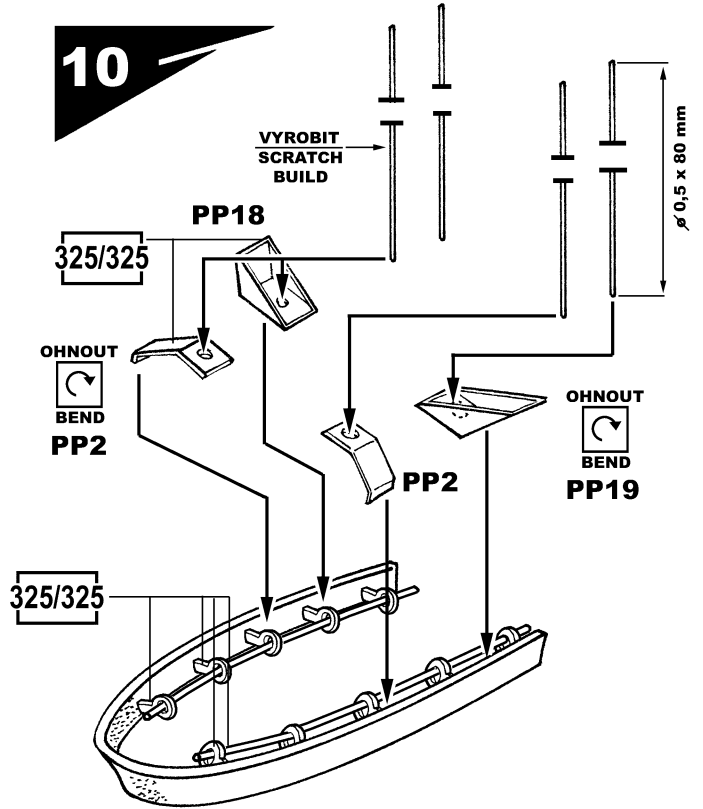

11

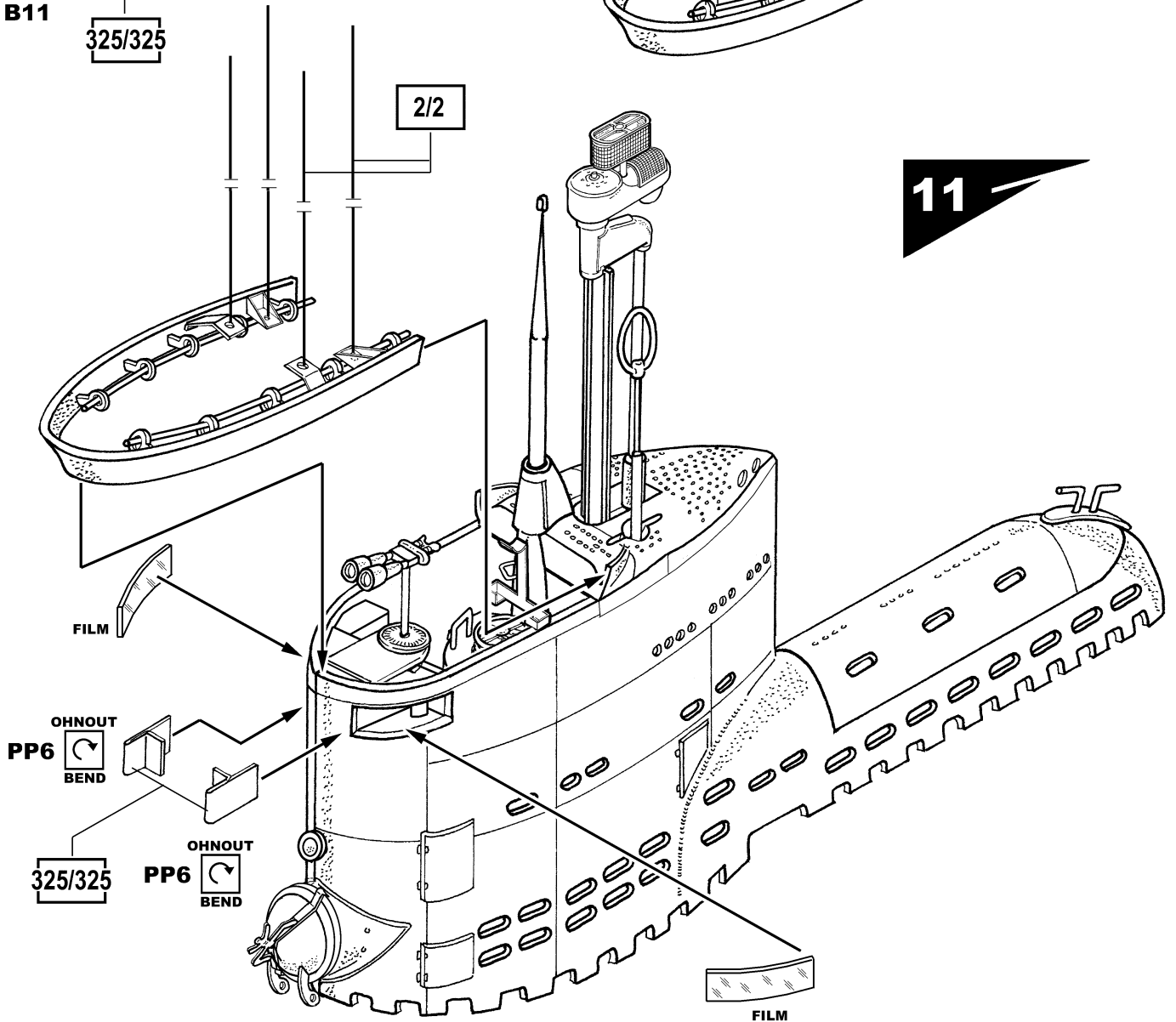

14

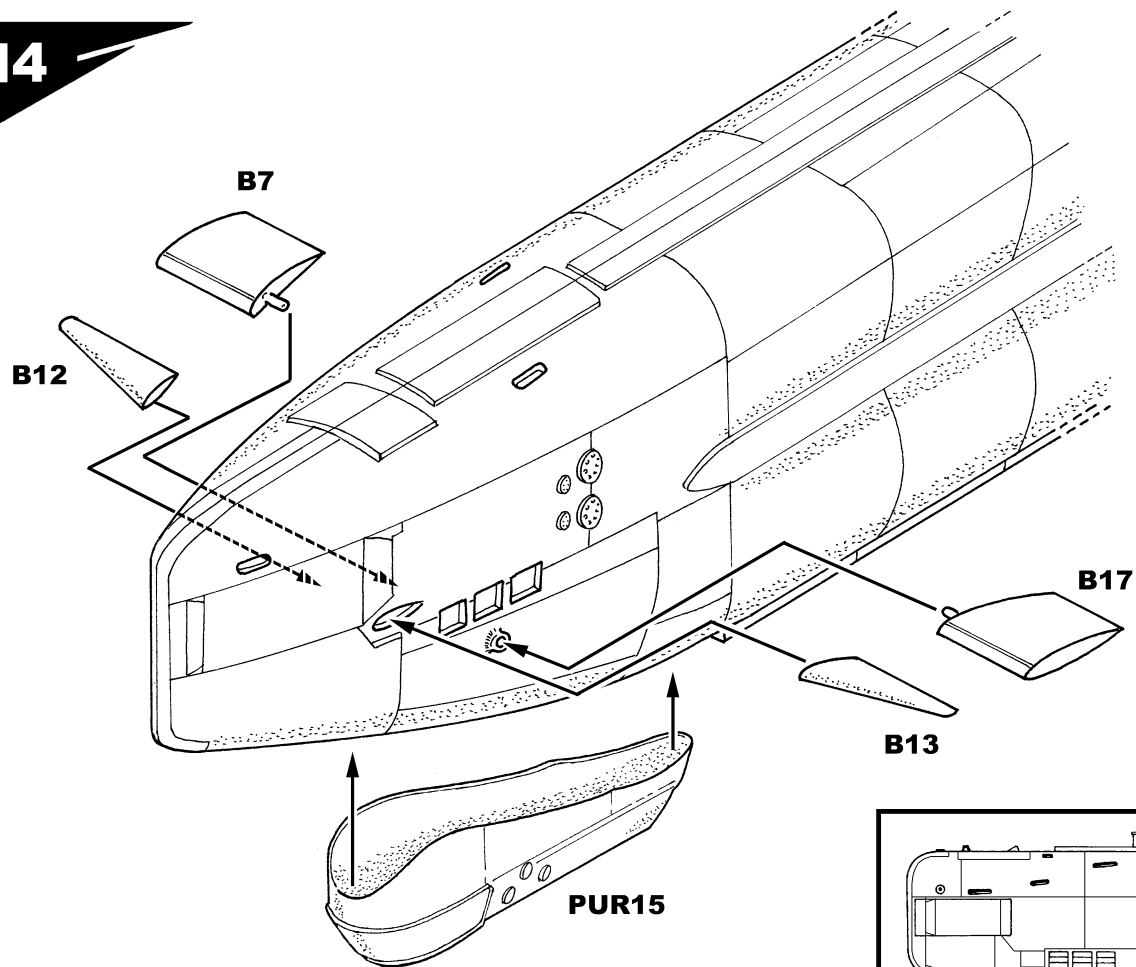

info

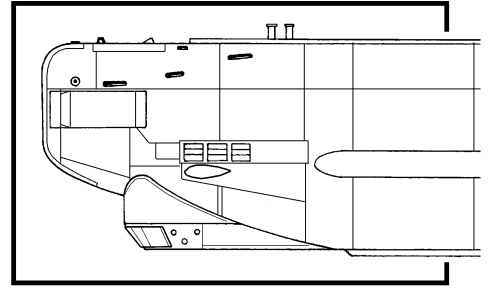

15

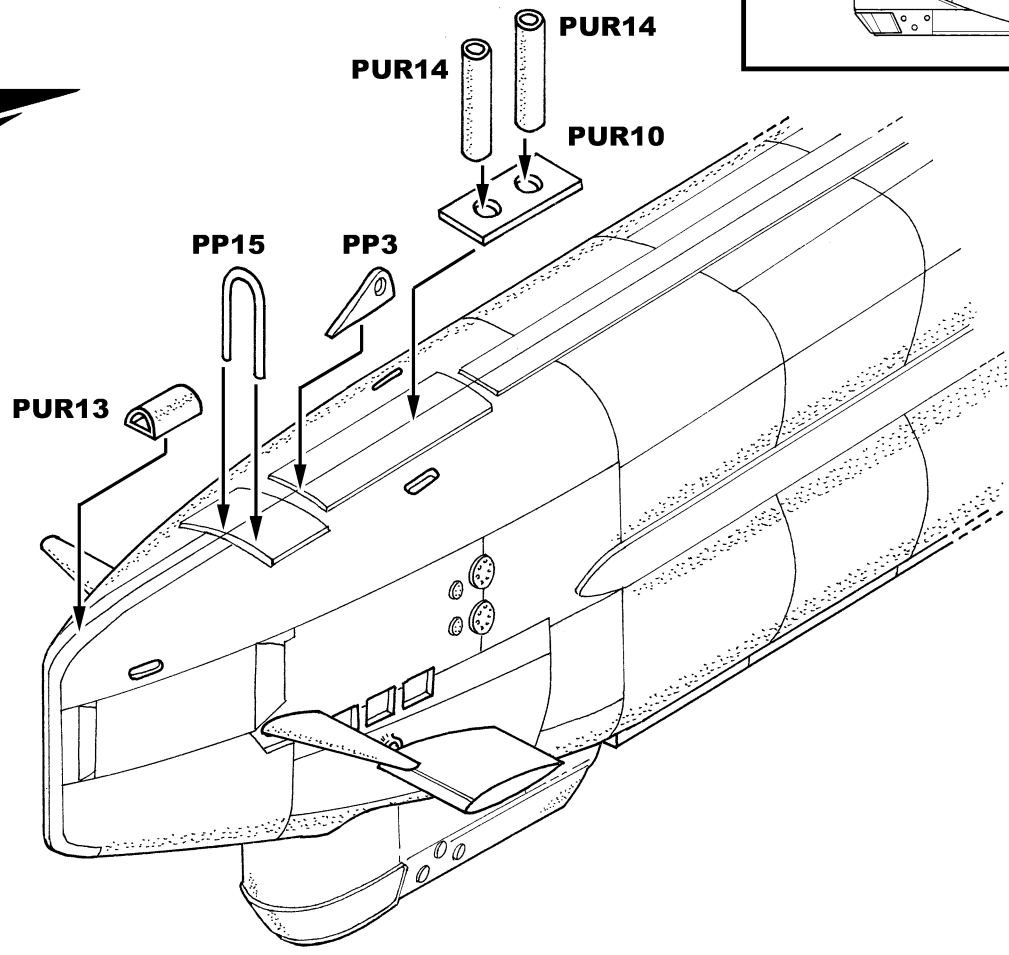

ASSEMBLY - SESTAVA

16

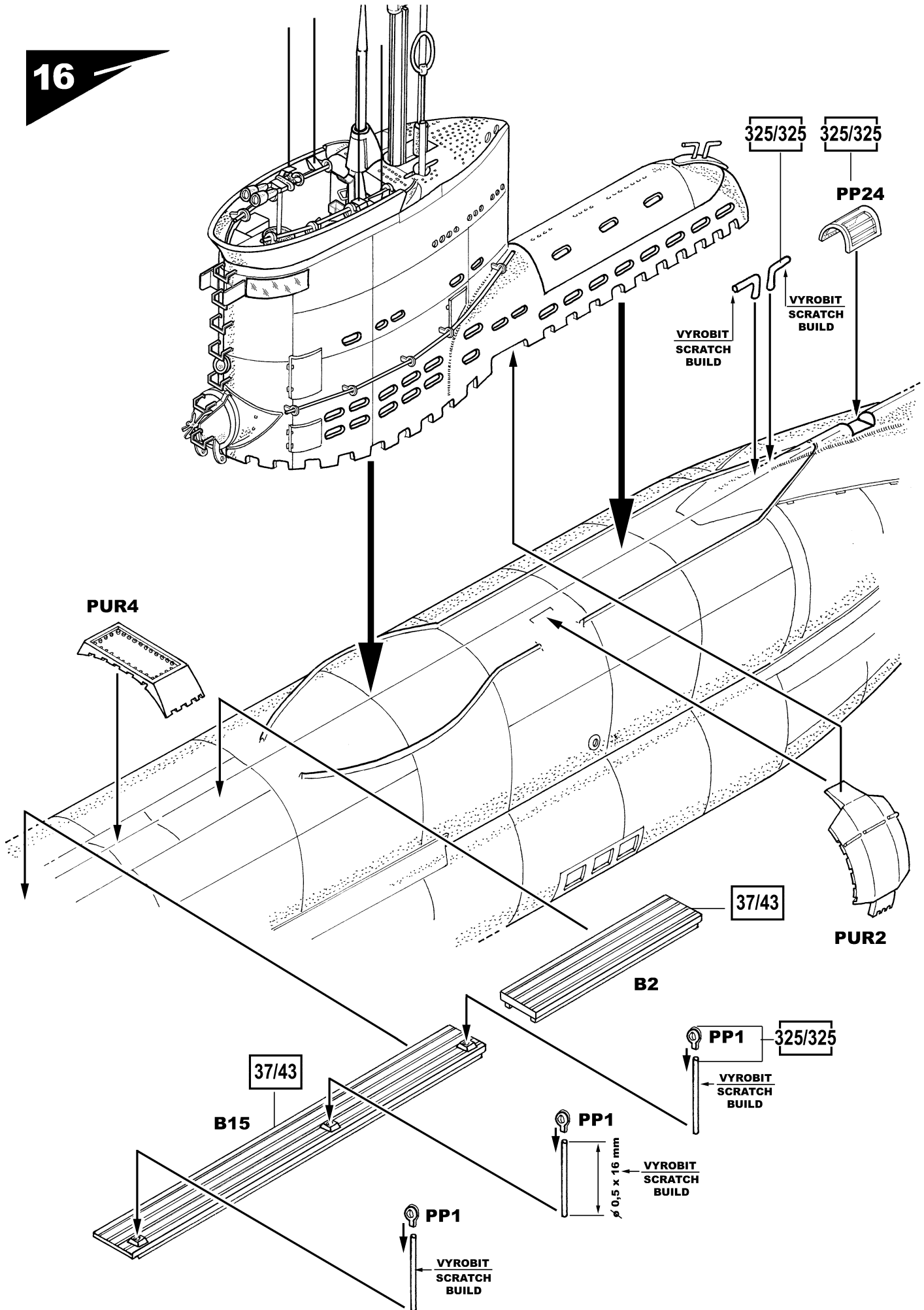

17

?

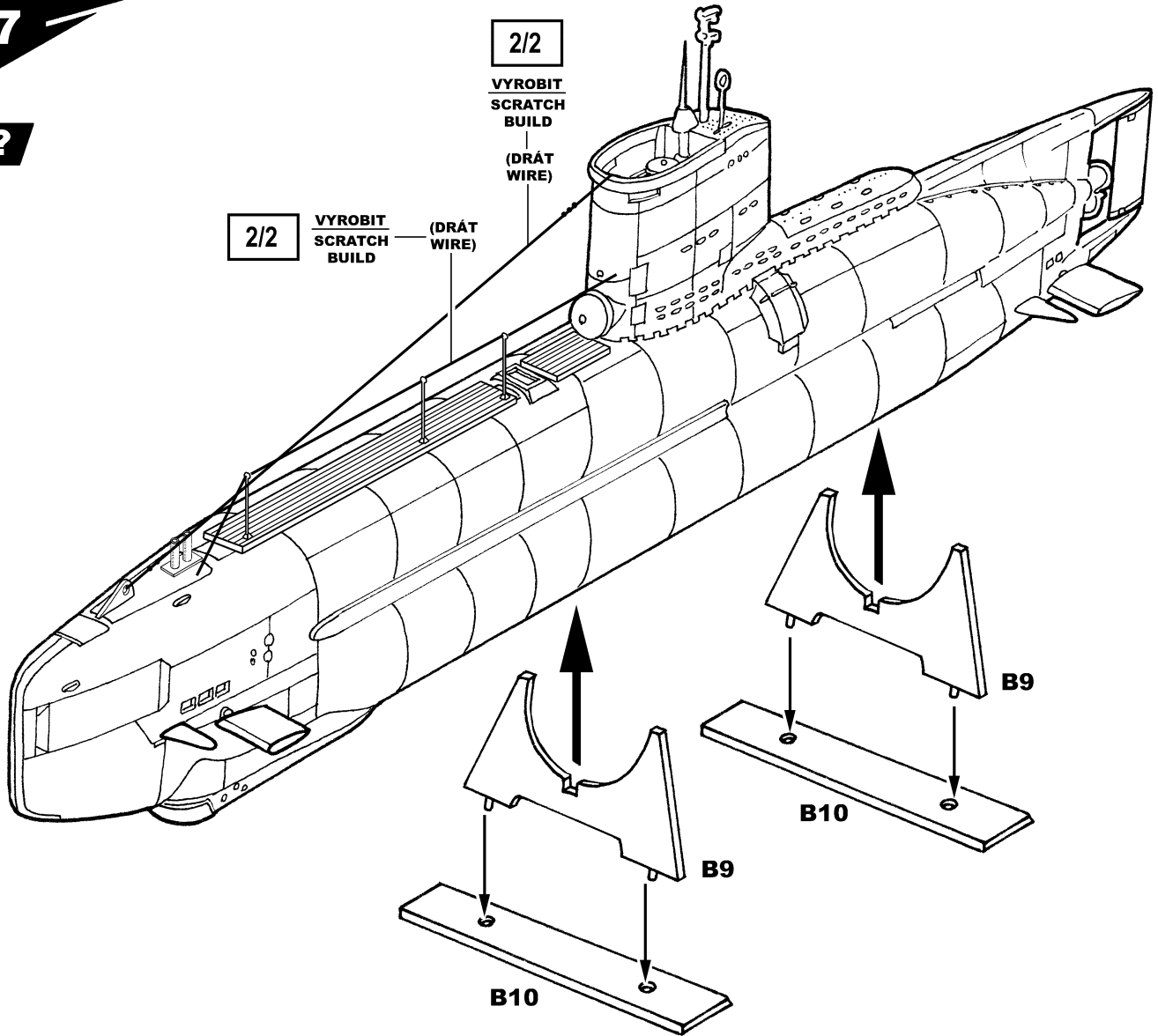

info

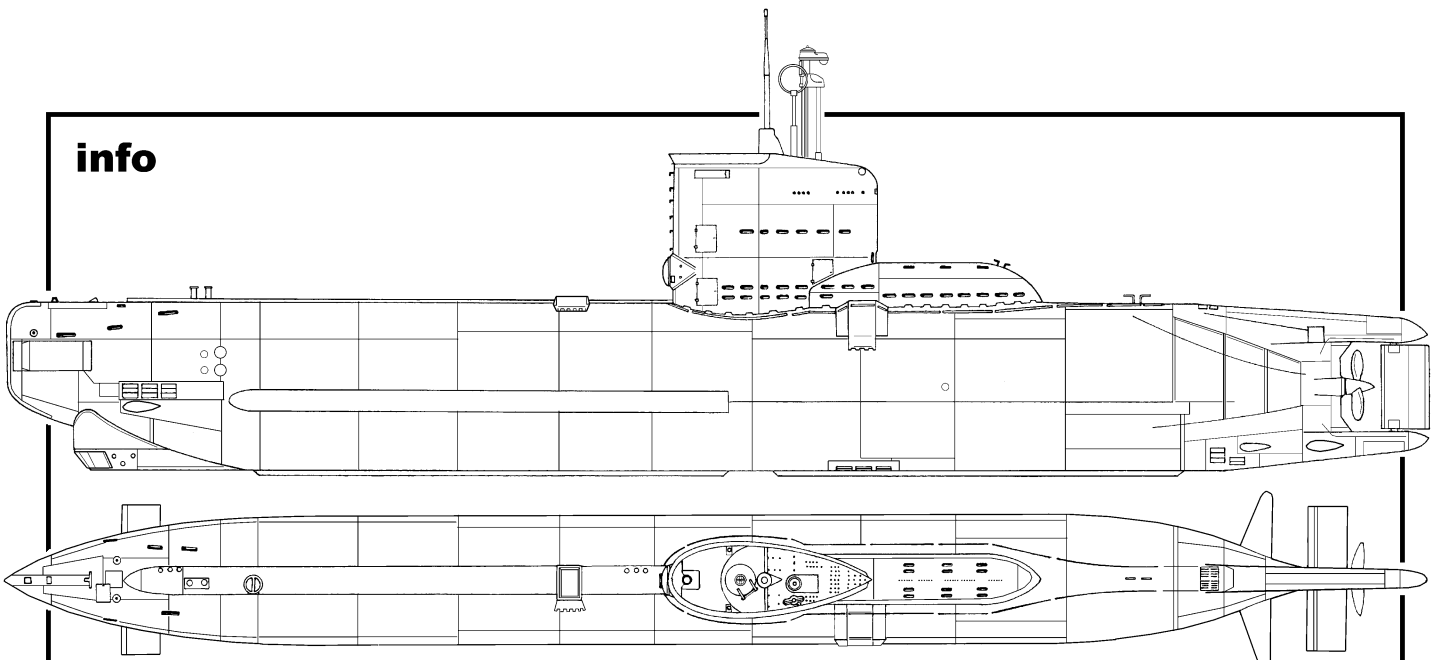

DRAWINGS.MA

CAMOUFLAGE and MARKING - ZBARVENÍ a OZNAČOVÁNÍ



U-Boot typ XXIII, U 2321, velitel npor. Barschkis, květen 1945
U-Boot typ XXIII, U 2321, shipmaster first-lieutenant Barschkis, May 1945

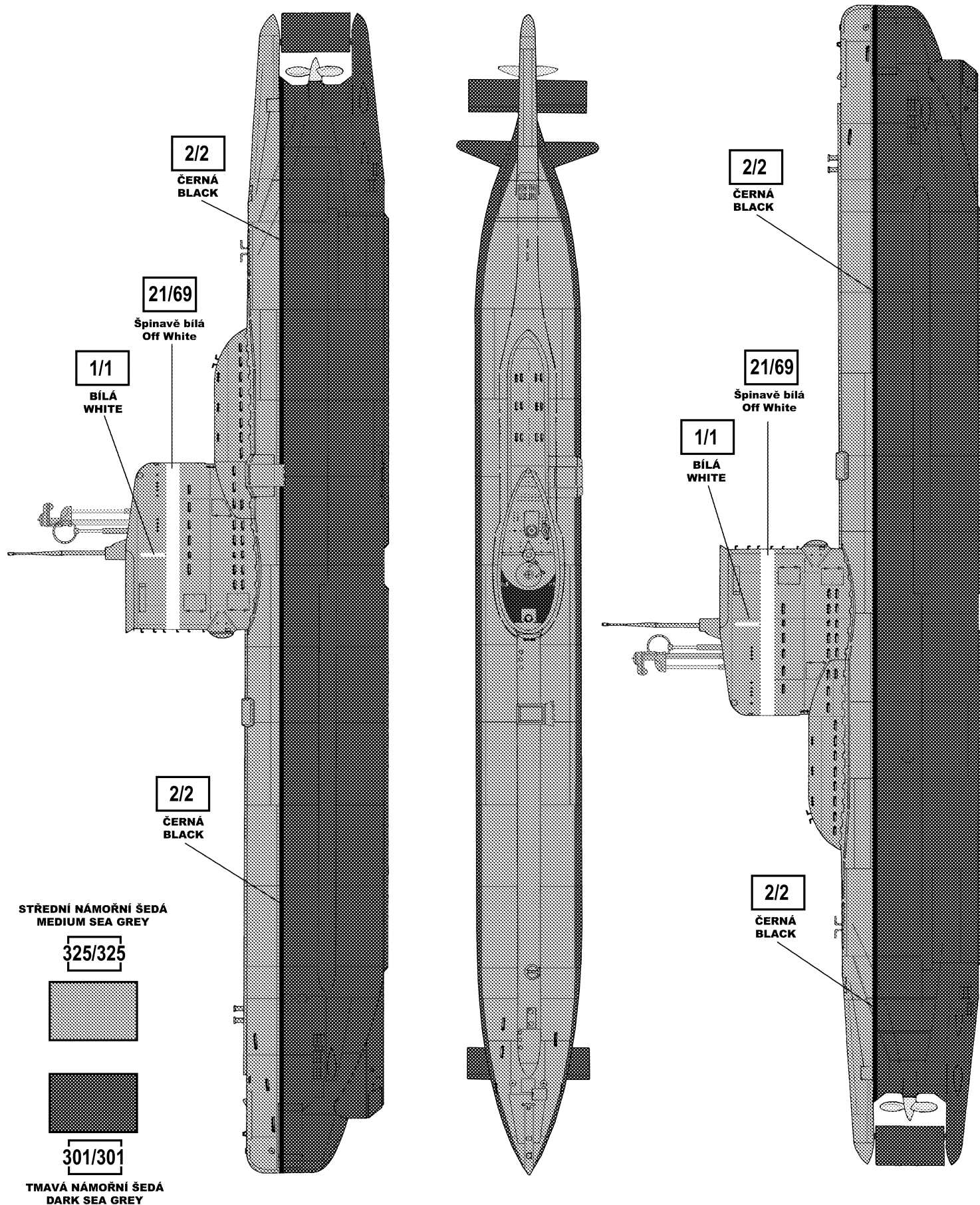

ZBARVENÍ a OZNAČOVÁNÍ

CAMOUFLAGE and MARKING - TARNUNG und KENNUNG - CAMOUFLAGE et DESIGNATION



U-BOOT TYPE "XXIII" - U 2332

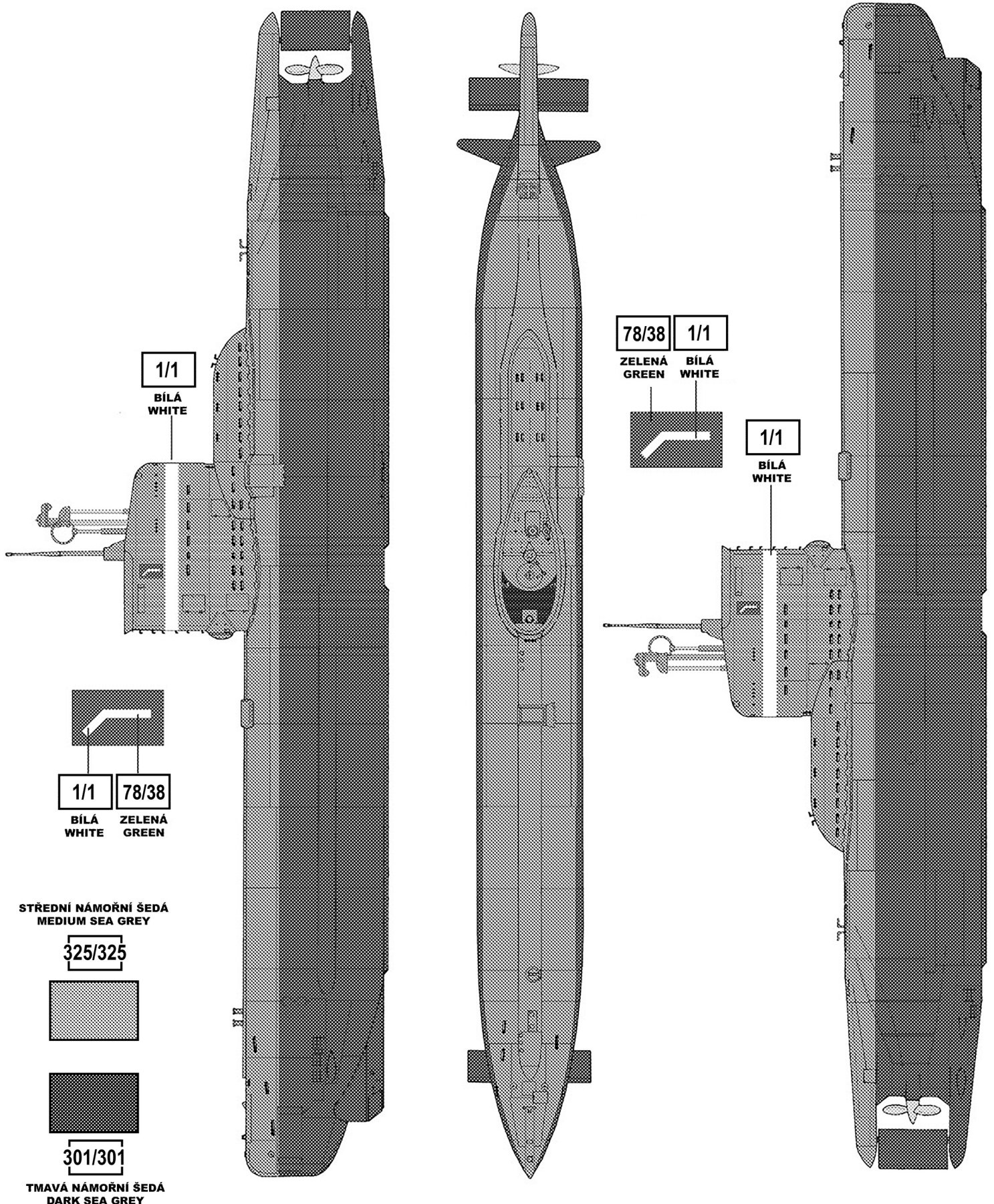

1/1
BÍLÁ
WHITE

78/38 1/1
ZELENÁ BÍLÁ
GREEN WHITE

1/1
BÍLÁ
WHITE



1/1 78/38
BÍLÁ ZELENÁ
WHITE GREEN

STŘEDNÍ NÁMOŘNÍ ŠEDÁ
MEDIUM SEA GREY

325/325



301/301

TMAVÁ NÁMOŘNÍ ŠEDÁ
DARK SEA GREY

ZBARVENÍ a OZNAČOVÁNÍ

CAMOUFLAGE and MARKING - TARNUNG und KENNUNG - CAMOUFLAGE et DESIGNATION



U-BOOT TYPE "XXIII" - U 2332

