

## 3,7 cm KPÚV typ M vz.37/ 3,7 cm PAK (t)

### NÁVOD / INSTRUCTIONS

**CZ – Historie** Plzeňské Škodovy závody byly tradičním dodavatelem děl již od dob Rakouska-Uherska. Na tuto tradici navázala Škodovka po vzniku republiky Československé a stala se jedním z hlavních dodavatelů výzbroje nové československé armády. Zároveň byla i velkým exportérem zbraní do celého světa. Vývojové oddělení Škodových závodů navrhlo ve třicátých letech minulého století moderní protitankový kanón A3 ráže 37 mm. Ten byl přijat do výzbroje čs. armády pod označením 3,7 cm KPÚV vz.34 (**K**anón **P**roti **Ú**točné **V**ozbě). Škodováci ale neusli na vavřínech a vyvinuli modernizovanou variantu označenou A4. Při zkušebních střelbách kanón A4 dosáhl vynikajících výkonů a značně překonal 3,7 cm KPÚV vz.34. Nový kanón ale používal odlišné střelivo proti již zavedenému 3,7 cm KPÚV vz.34. Proto musel být upraven závěr nového kanónu pro použití jak nového střeliva i střeliva pro 3,7 cm KPÚV vz.34. Pak již nic nebránilo zavedení kanónu A4 do výzbroje. Čs. armáda jej zavedla pod označením 3,7 cm KPÚV vz.37. V té době to byl nejlepší kanón své kategorie na světě. Sériové 3,7 cm KPÚV vz.37 pro čs. armádu byly dodávány v provedení pro pěchotní jednotky s loukoťovými koly jako typ P, pro jezdeckto byl určen typ J s diskovými koly s pneumatikami a novou jezdeckou kolesnou. Typ M taktéž s diskovými koly s pneumatikami byl určen pro motorizovanou přepravu. Kanóny A4 byly také exportovány, mimo jiné do Jugoslávie, Bulharska a Maďarska. V roce 1938 bylo na obranu Československa připraveno skoro tisíc 3,7 cm KPÚV vz.34 a 3,7 cm KPÚV vz.37, z toho 390 ks bylo 3,7 cm KPÚV vz.37 P a 300 ks 3,7 cm KPÚV vz.37 M. 3,7 cm KPÚV vz.37 dokázal prostřelit pancíře všech tehdejších tanků Wehrmachtu. V boji je ale nakonec nasadil právě Wehrmacht. Do výzbroje německé armády, která zjistila, že 3,7 cm KPÚV vz.37 je kvalitnější než německé kanóny stejné ráže, byl zařazen jako 3,7 cm PAK 37(t). Jak jsou účinné, zjistili ke své škodě vojáci Polska, Belgie, Lucemburska, Nizozemí a Francie. Teprve útok na Sovětský svaz odsunul tyto kanóny do druhé linie, proti pancířům nových sovětských středních a těžkých tanků byly kanony ráže 37 mm neúčinné. Ve výzbroji ale zůstaly prakticky do konce války. Dalším uživatelem byla armáda Slovenského štátu, který vznikl na troskách Československa. I Slovenský štát nasadil 3,7 cm KPÚV vz.37 při útoku na Sovětský svaz, s podobnými problémy jako Wehrmacht.

**CZ – Historie** The Skoda Works in Pilsen had been a traditional gun manufacturer and supplier already since the times of the Austro-Hungarian Empire, and after the independent Czechoslovak Republic was established in 1918, the company continued in this tradition and became one of the major armament suppliers for the new Czechoslovak Army and also exported large numbers of weapons world wide. In the 1930s, the Skoda development department came up with a design for a modern 37mm A3 anti-tank gun, which was later accepted by the Army and used under designation 3,7cm KPUV vz.34, (KPUV standing for **K**anón **P**roti **Ú**točné **V**ozbe, or Anti-Tank Gun). The Skoda design team did not lie back on their laurels and developed a modernised type known as the A4 which gained excellent results while it was being tested and surpassed considerably the original 3,7cm KPUV gun. However, the new type used a different type of ammunition and therefore its breech had to be redesigned to be capable of using the earlier ammo as well. After that, nothing stood against the A4 gun being accepted by the Czechoslovak Army, which used it under 3,7cm KPUV vz.37 designation. At that time, this weapon was the world's best in its category. The production guns were supplied in several varieties, as Type P for infantry units (P=pěchota, or Infantry) with spoked wheels, for cavalry units as Type J (J for jezdeckto, Cavalry) with pneumatic wheels with standard discs and as Type M which could have been transported behind a motorised vehicles. The A4 guns were also exported to Yugoslavia, Bulgaria and Hungary, besides others. In 1938, nearly one thousand KPUV guns of both types were ready to defend Czechoslovakia, 390 of them were of vz.37 Type P and 300 of vz.37 Type M. The 3,7cm KPUV Gun vz.37 was capable to shoot through the armour of all Wehrmacht's tanks. However, in the end, these guns were first used in combat by the German Wehrmacht, which, having realised the Czechoslovak guns were superior to German ones, put them into service under 3,7cm PAK 37(t) designation. And, how effective these guns were, soldiers of Poland, France, Belgium, Luxembourg and the Netherlands found out to their detriment. In the end, only the attack against the Soviet Union made the 37mm guns obsolete as they were no longer effective against the new Soviet mid and heavy tank armours. Nevertheless, the guns remained on strenght almost until the end of the war. Amongst their users were also the army of the Slovak State, which had been built on the ruins of former Czechoslovakia, the Slovak Army deployed the 3,7cm guns also against the USSR, but with similar trouble as the Wehrmacht.

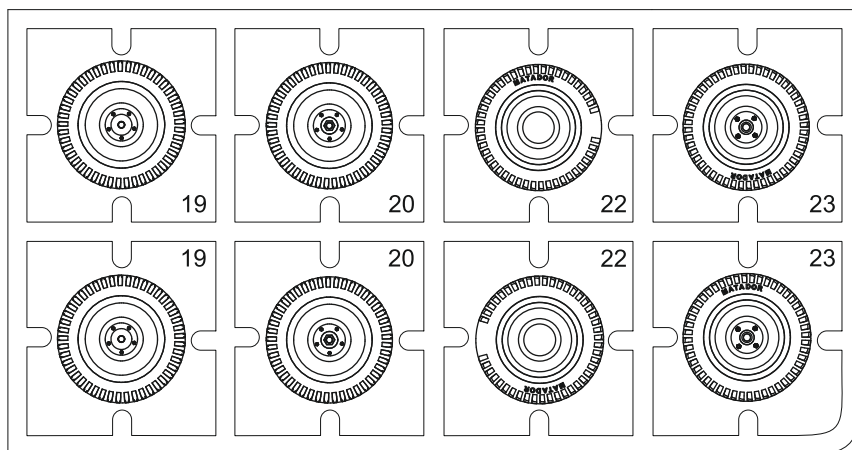
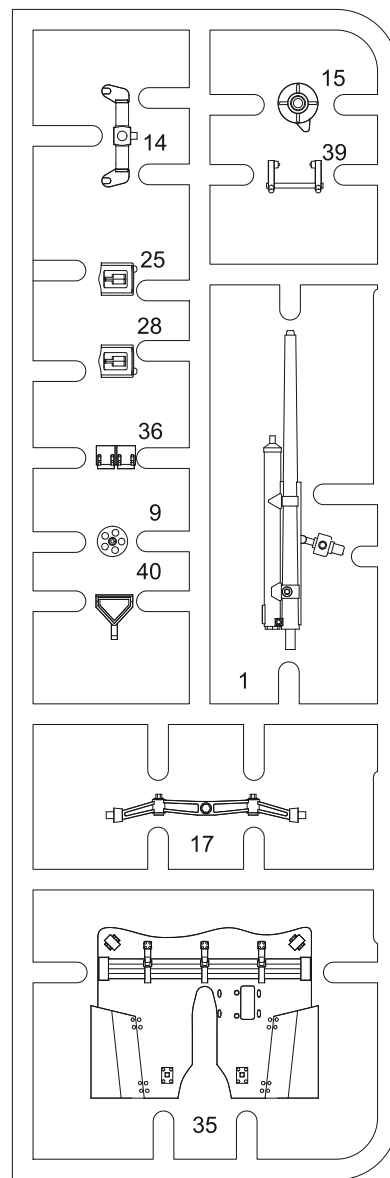
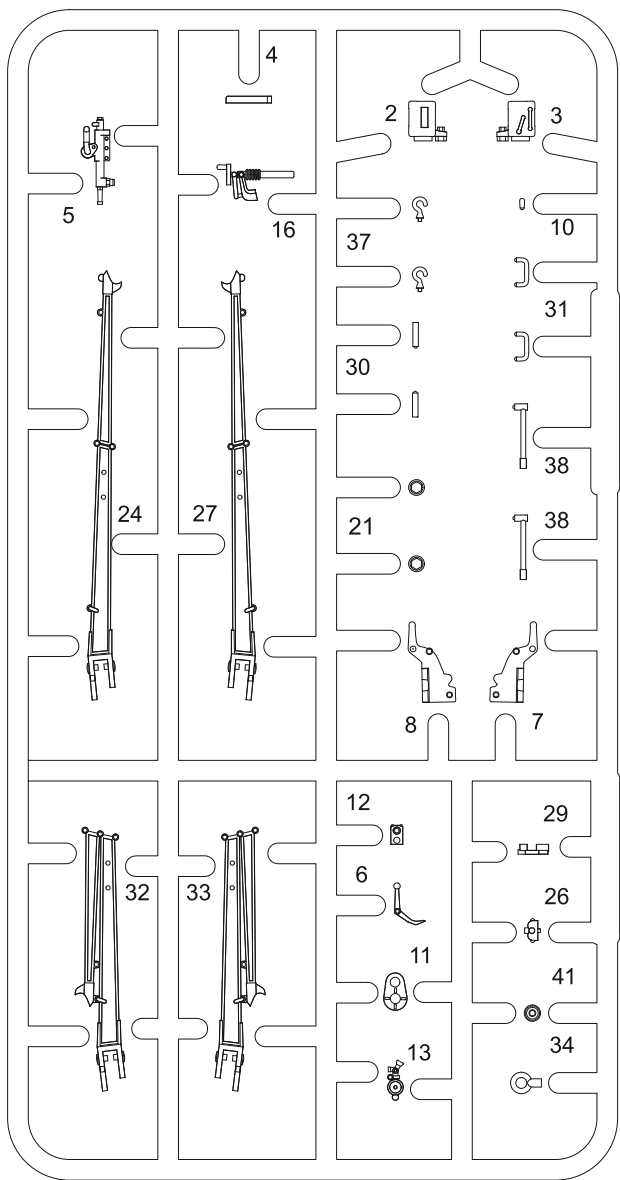

<b>A</b>	<i>Tmavá zemitá / Dark Earth</i>	<i>H72 / C22</i>	<b>Barvy GUNZE/ GUNZE Colour No.</b>	<b>E</b>	<i>Špinavě bílá / Off White</i>	<i>H21 / C69</i>
<b>B</b>	<i>Světle zelená / Bright Green</i>	<i>H26 / C66</i>		<b>F</b>	<i>Ocel / Steel</i>	<i>H18 / C28</i>
<b>C</b>	<i>Tmavě žlutá / Dark Yellow</i>	<i>H79 / C39</i>		<b>G</b>	<i>Barva pneu / Tire Black</i>	<i>H79 / C39</i>
<b>D</b>	<i>Polní šedá / Field Gray</i>	<i>H32 / C40</i>		<b>H</b>	<i>Červenohnědá / Red Brown</i>	<i>H47 / C41</i>

### SYMBOLS



MOŽNOST VOLBY  
OPTIONAL  
NACH BELIEBEN  
OPTION



POUŽÍT KYANOAKRYLÁTOVÉ LEPIDLO  
INSTANT CYANOACRYLATE GLUE  
ZYANOAKRYLÁTKLEBER  
COLLE CYANOACRYLAT



OHNOUT  
BEND  
BIEGEN  
COURBER



ZHOTOVIT NOVĚ  
SCRATCH BUILD  
FERTIGSTELLEN  
ACHEVER



ŘEZAT/VRTAT  
CUT OFF/DRILL  
ENTFERNEN  
DETACHER



GSI **A** NATŘÍT  
COLOUR  
FARBEN  
PEINDRE  
colour code

# 1a

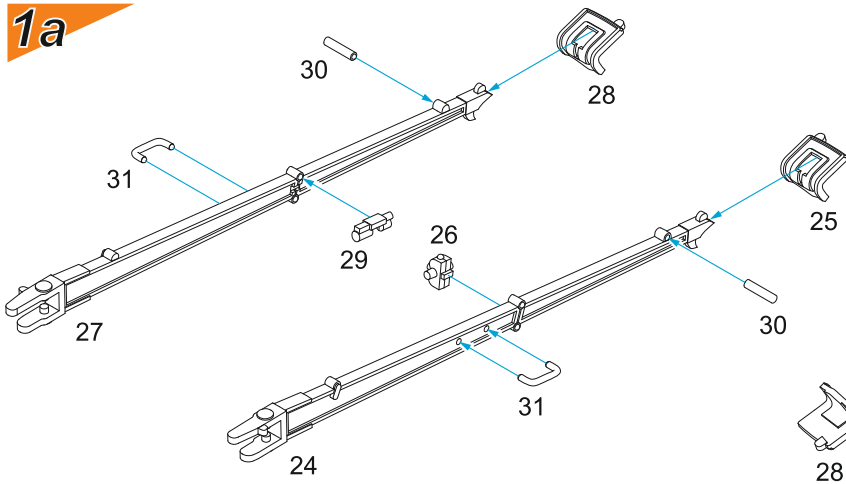

# 1b

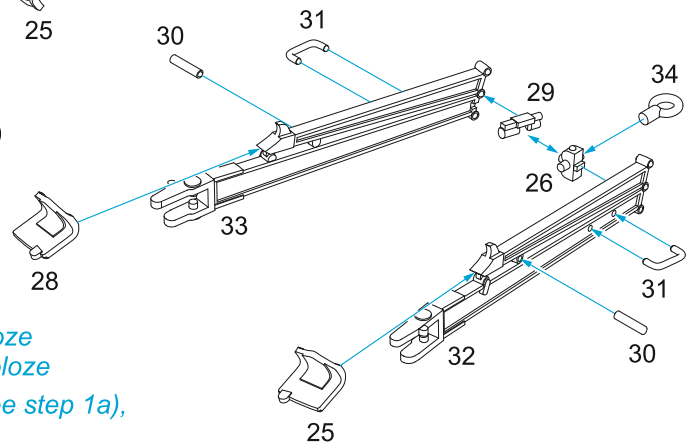

*V kroku 1a sestavíte lafetová ramena v palebné poloze*  
*V kroku 1b sestavíte lafetová ramena v trasportní poloze*  
**Note/ Pozn.** The carriage trails can be posed in firing position (see step 1a),  
 or in travelling position (see step 1b)

# 2a

## Step 1a

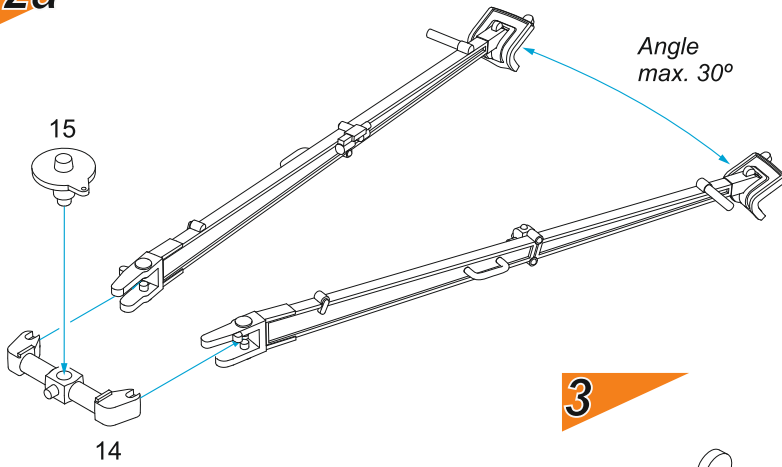

# 2b

## Step 1b

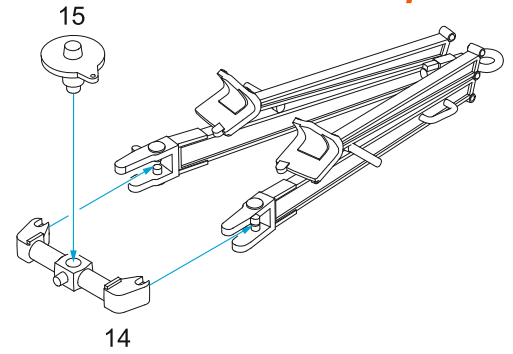

# 3

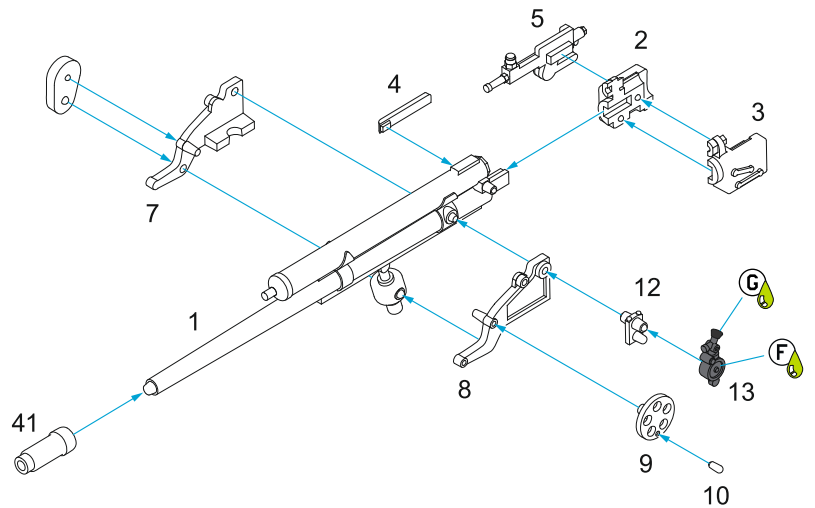

# 4

## Step 3

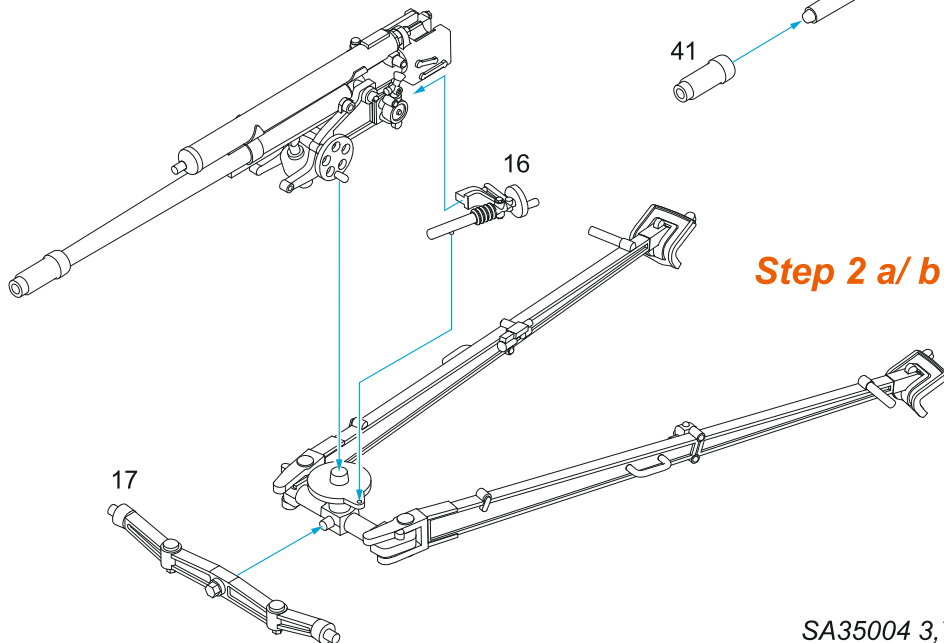

## Step 2 a/ b

5

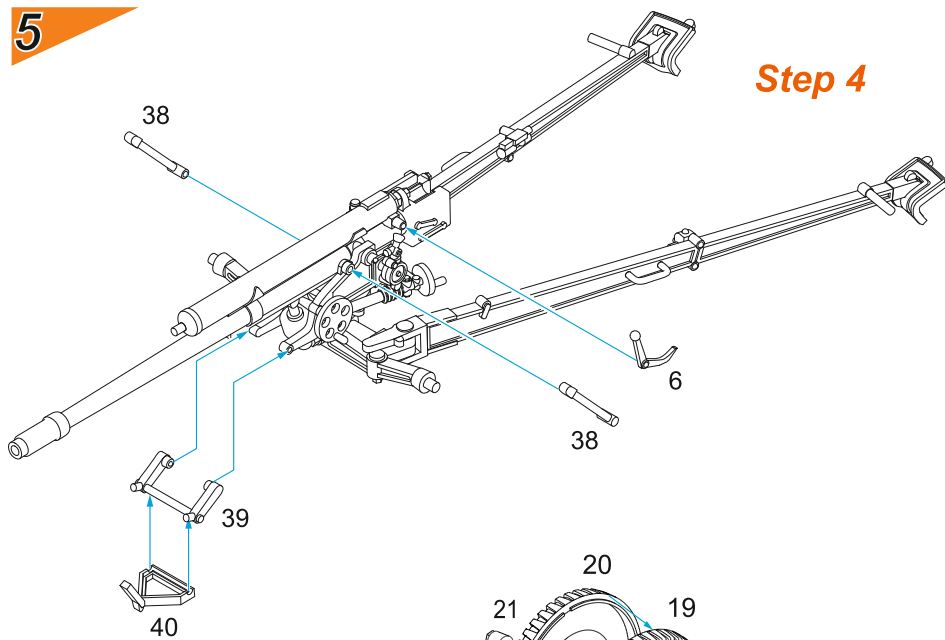

Step 4

6

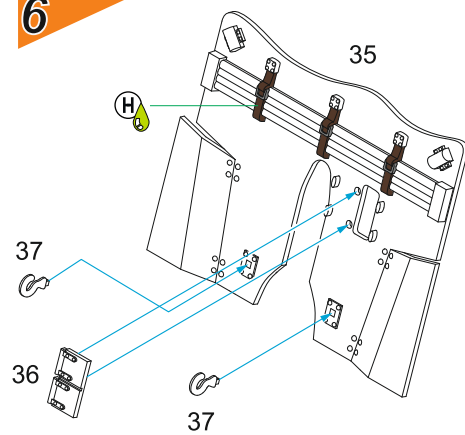

Step 6

7

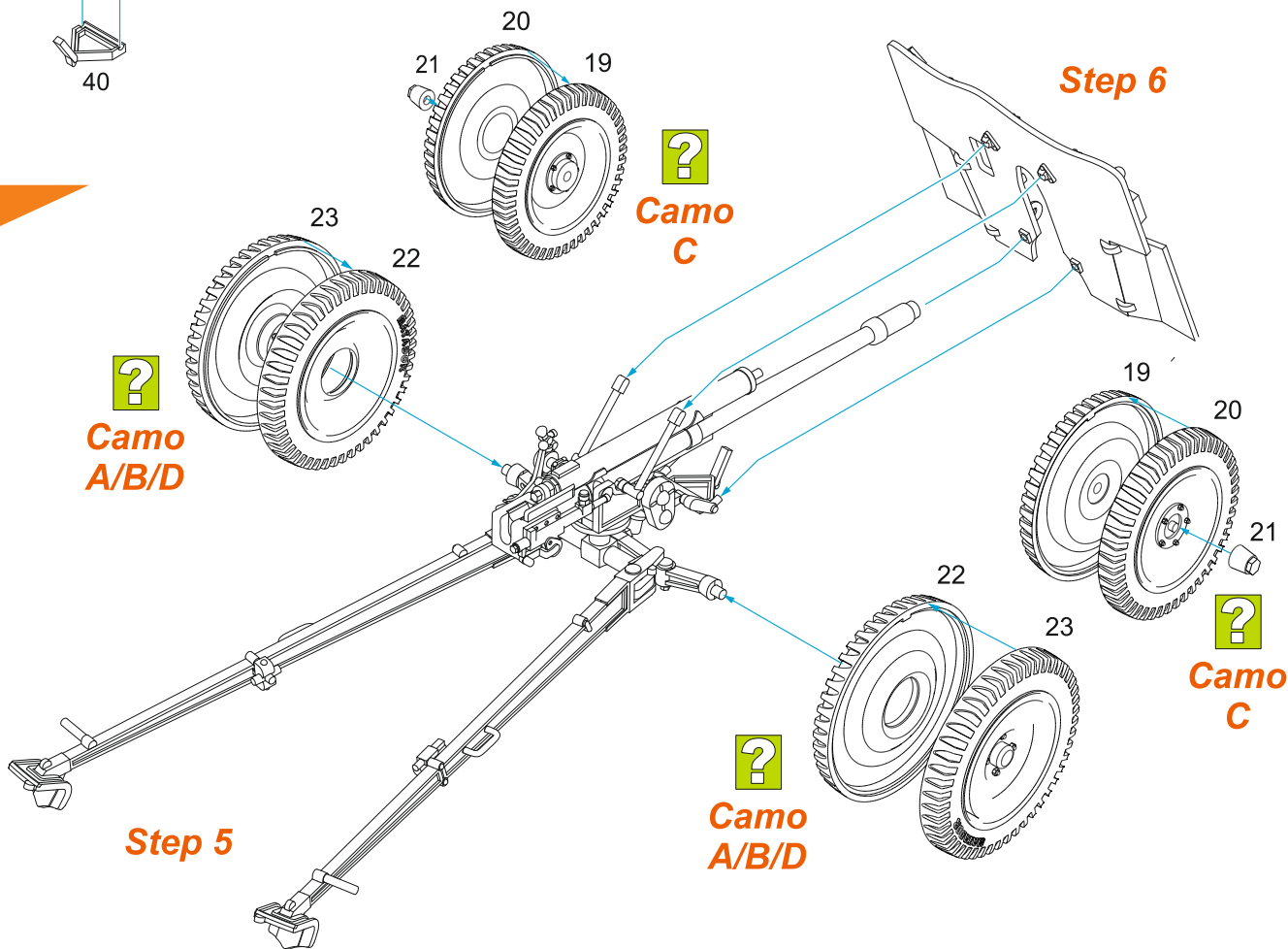

Step 5

Celkový pohled kanonu s lafetovými rameny v transportní poloze.

Overall view of the gun with the trail in travelling position.

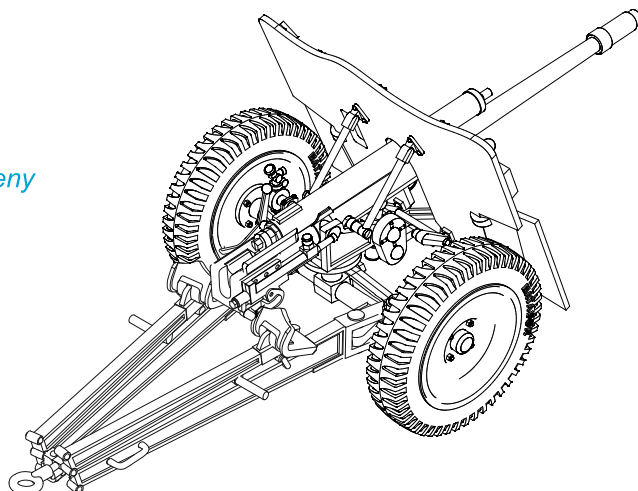

3,7 cm KPÚV vz.37 typ M, Československá armáda, 1938.

3,7 cm KPÚV vz.37 typ M, Czechoslovak Army, 1938.

CAM. A

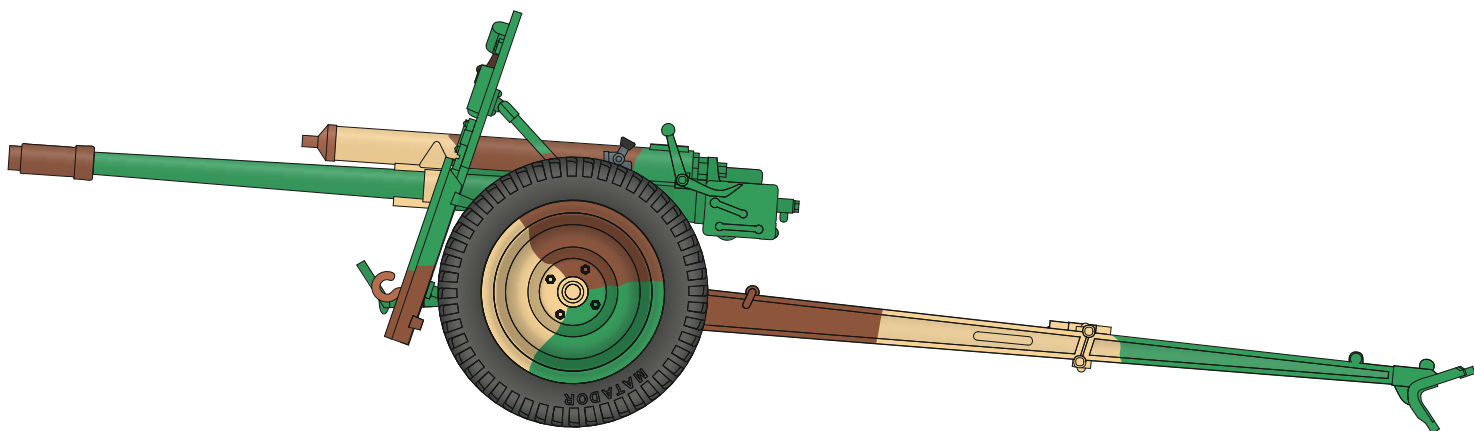
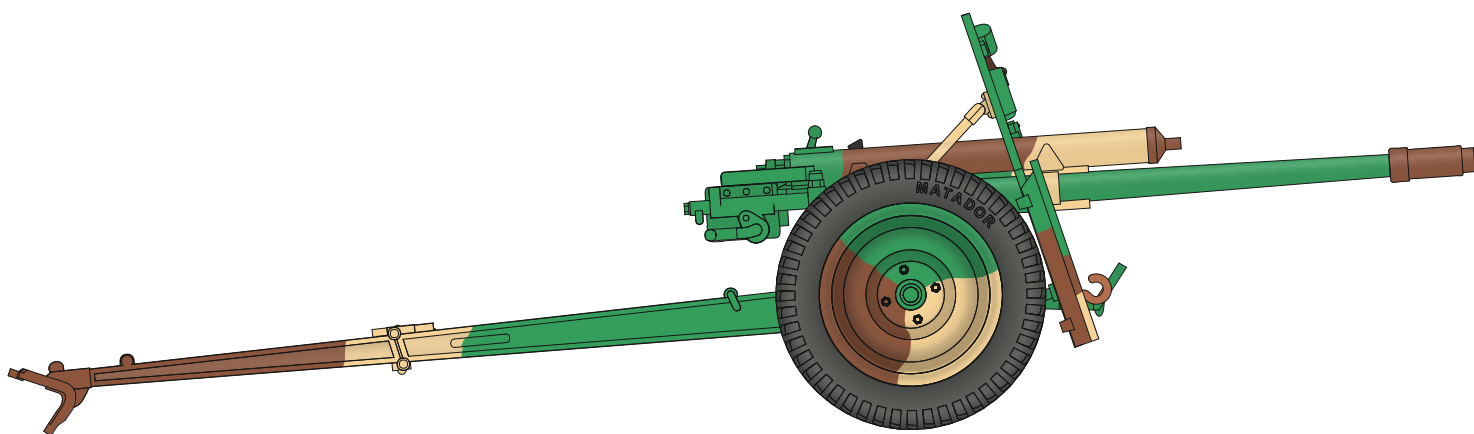
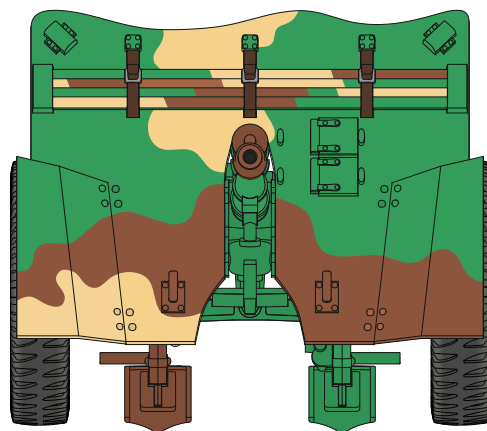
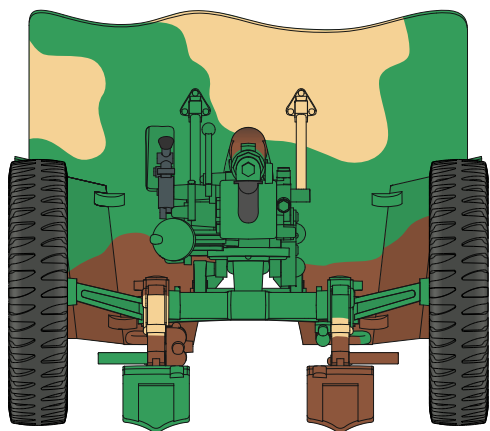

 Tmavá zemitá  
Dark Earth  
H72/C22

 Světle zelená  
Bright Green  
H26/C66

 Tmavě žlutá  
Dark Yellow  
H79/C39

 Barva pneu  
Tire Black  
H77/C137

Aspecial  
ARMOUR

GUNZE  
SANGYO

06/2017

SA35004 3,7 cm KPÚV typ M vz.37/ 3,7 cm PAK (t)

5

3,7 cm KPÚV vz.37 typ M, rota kanónů proti útočné vozbě, motorizovaná Rychlá skupina Slovenské armády, Lipovec, Ukrajina, Východní fronta, červenec 1941.

3,7 cm KPÚV vz.37 typ M, Anti-tank gun company (motorised), Slovak Army Mobile Group, Lypovets, Ukraine, Eastern Front, July 1941.

**CAM. B**

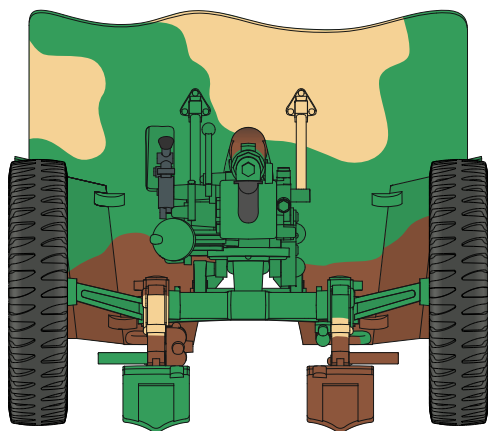

Obtisk  
Decal

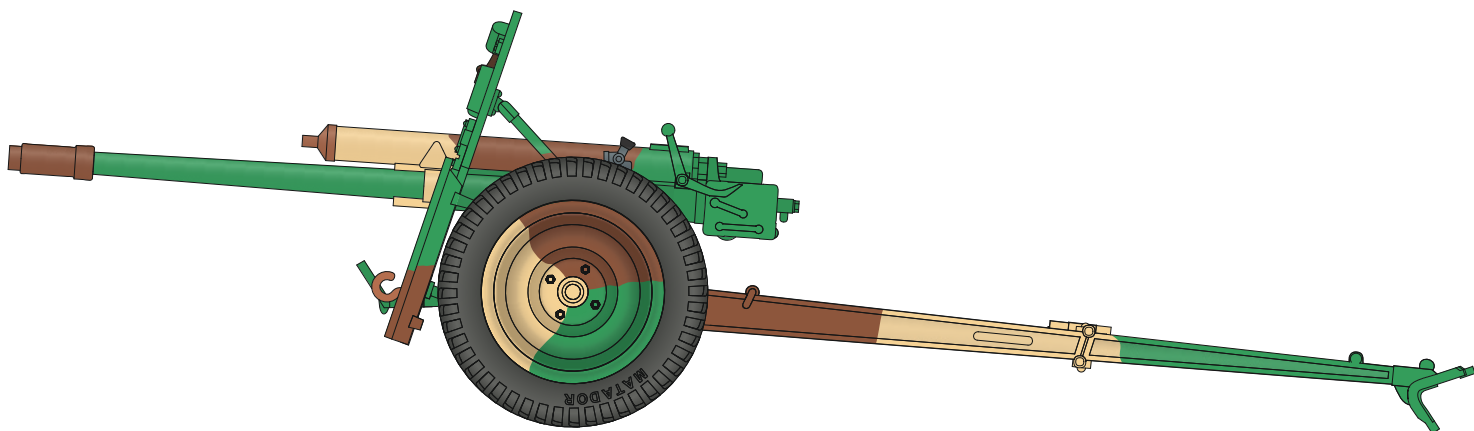
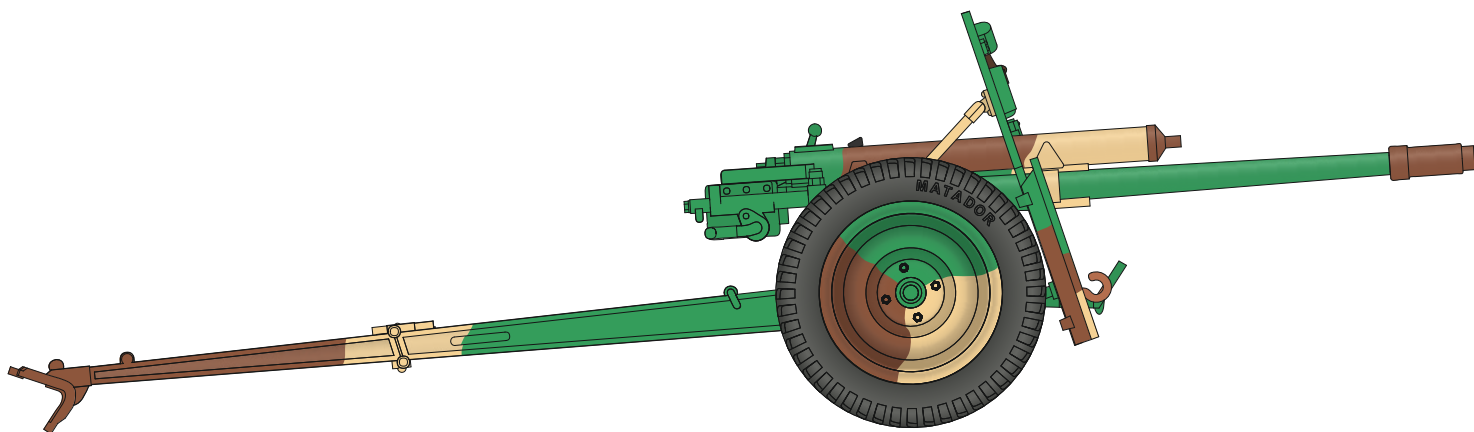
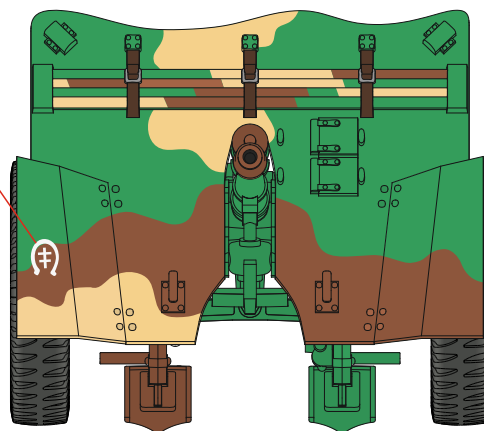

Tmavá zemitá  
Dark Earth  
H72/C22

Světle zelená  
Bright Green  
H26/C66

Tmavě žlutá  
Dark Yellow  
H79/C39

Barva pneu  
Tire Black  
H77/C137



06/2017

SA35004 3,7 cm KPÚV typ M vz.37/ 3,7 cm PAK (t)

6

3,7 cm PAK 37(t), neznámá jednotka Wehrmachtu,  
útok na Polsko, září 1939.

3,7 cm PAK 37(t), unknown unit of the Wehrmacht,  
Invasion of Poland, September 1939.

CAM. C

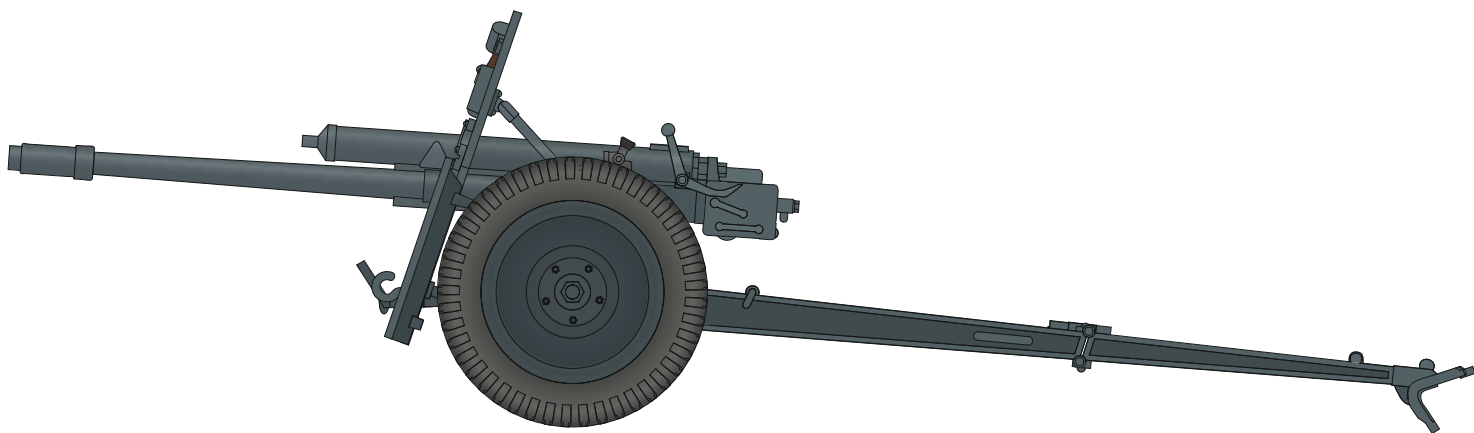
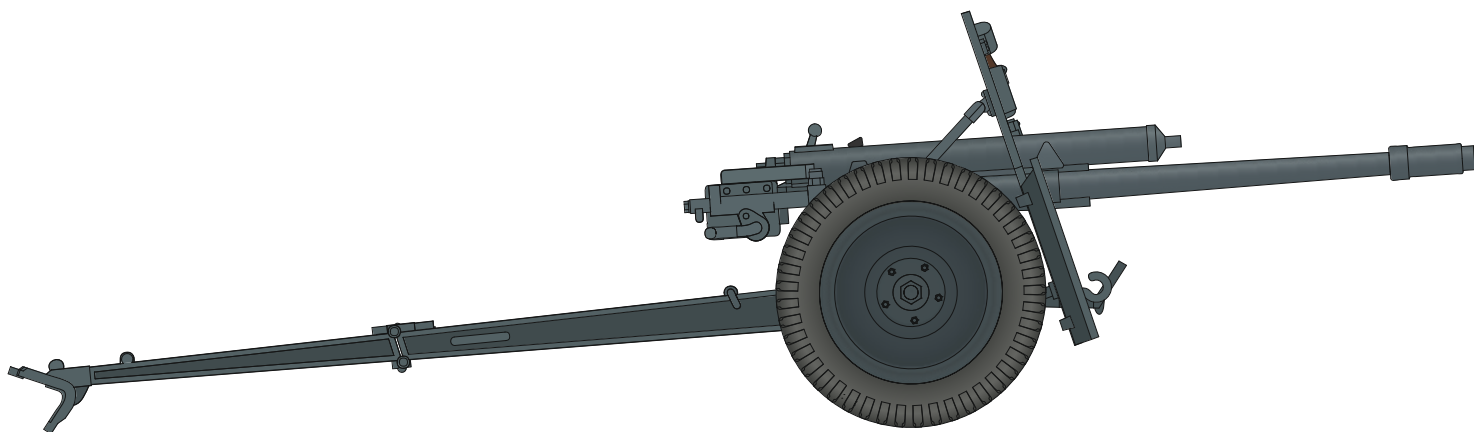
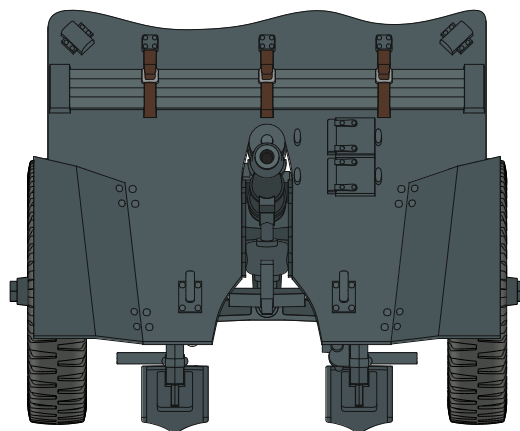
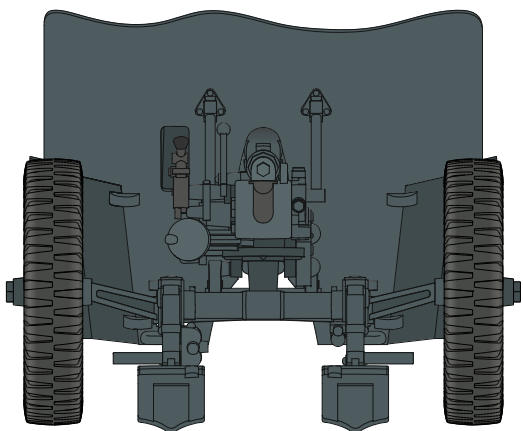

Polní šedá  
Field Gray  
H32/C40

Barva pneu  
Tire Black  
H77/C137

Aspecial  
ARMOUR  
GUNZE  
SANGYO

SA35004 3,7 cm KPÚV typ M vz.37/ 3,7 cm PAK (t) 7

06/2017

3,7 cm PAK 37(t), neznámá jednotka Wehrmachtu, období Podivné války (Sitzkrieg), západní hranice Německa, zima 1939/40.

3,7 cm PAK 37(t), unknown unit of the Wehrmacht, Phoney War (Sitzkrieg), Germany's western border, Winter 1939–1940.

CAM. D

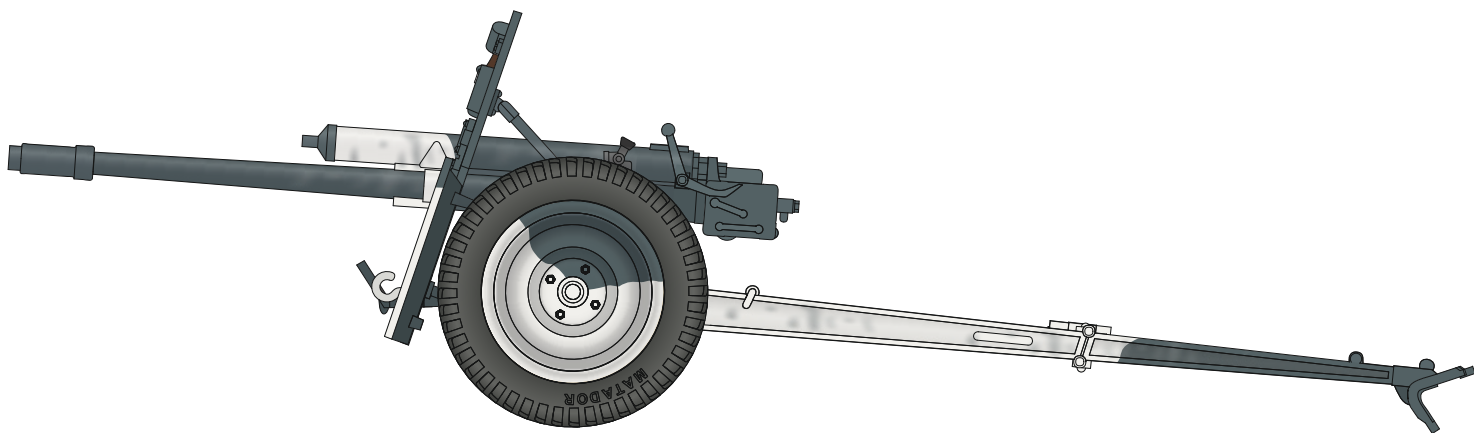
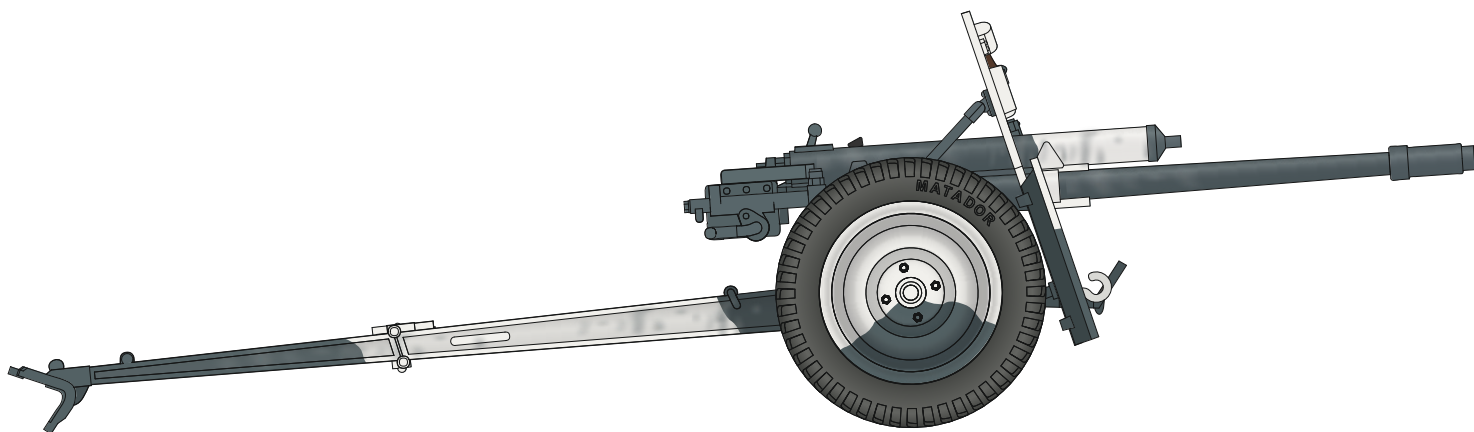
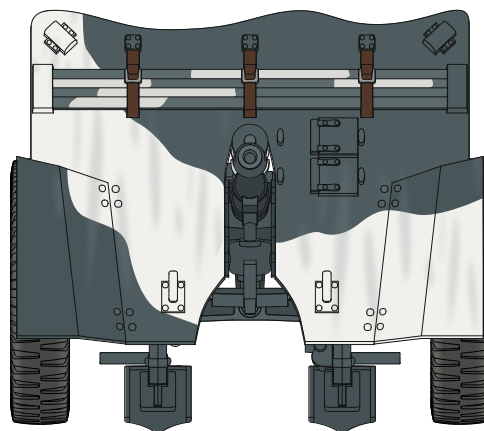
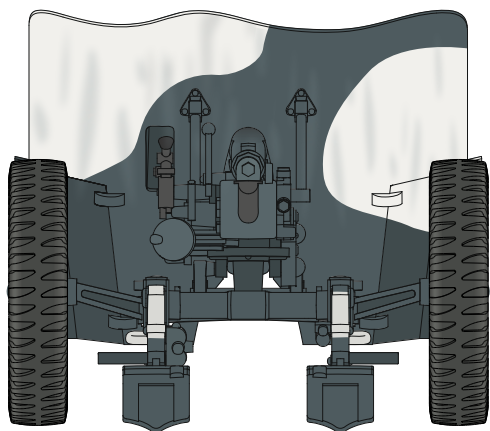

Polní šedá  
Field Gray  
H32/C40

Špinavě bílá  
Off White  
H21/C69

Barva pneu  
Tire Black  
H77/C137

Aspecial  
ARMOUR  
GUNZE  
SANGYO

06/2017

SA35004 3,7 cm KPÚV typ M vz.37/ 3,7 cm PAK (t)

8