

AF-2 Guardian 'Fire Bomber'

Historie

CZ

V padesátých letech minulého století operovaly z letadlových lodí US Navy dvojice protiponorkových letounů AF-2 Guardian. Zatímco AF-2W nesl pod trupem objemný vyhledávací radar APS-20, druhá verze AF-2S nesla v pumovnici a pod křídlem protiponorkovou útočnou výzbroj (protiponorková torpéda, hlubinné pumy či rakety, útočný radar).

Vývoj Guardianu byl zahájen již za druhé světové války, ovšem původně US Navy požadovalo torpédový bombardér. U firmy Grumman dostal tento projekt označení G-70 a námořnictvo jej značilo jako XTB3F-1. XTB3F-1 měl mít kombinovaný pohon, v přídí umístěný hvězdicový motor P&W R-2800 měl pohánět čtyřlístou vrtuli, v ocasní části měl být instalován proudový motor Westinghouse 19XB. Proudový motor byl vymontován ještě před prvním letem. K tomu došlo 19. prosince 1945.

24. prosince 1945 však US Navy změnilo své požadavky a požadovalo přestavbu na protiponorkový letoun ve dvou výše zmíněných verzích.

Prototyp "Hunteru", jak byla nazývána verze AF-2W, vzlétl poprvé v listopadu 1948, prototyp "Killeru" v lednu následujícího roku. V roce 1950 byly první AF-2 obou verzí zařazeny do výzbroje US NAVY. Později je doplnila verze AF-3S. Ta odpovídala verzi AF-2S, ale nesla navíc detektor magnetických anomálií.

AF-2 operovaly jak z letadlových lodí, tak pozemních základen. Během Korejské války zajišťovaly ochranu letadlových lodí US Navy v bojových oblastech. Z první linie byly staženy v roce 1955, ale u záložních jednotek sloužily až do roku 1957.

Guardiany se staly prvními specializovanými protiponorkovými stroji US Navy operujícími z letadlových lodí. Zároveň drží primát největších jednomotorovými stroji s pístovým motorem v řadové službě, které kdy z palub lodí US Navy operovaly.

History

GB

During the 1950s, AF-2 Guardian anti submarine aircraft were operating from the decks of US Navy aircraft carriers in Hunter Killer pairs. These pairs consisted of the AF-2W version, which performed the 'Hunter' role using its volumous fuselage mounted AP-20 search and early warning radar to locate submarines while the second aircraft of the pair was the AF-2S which was the 'Killer' and carried offensive anti-submarine weapons such as torpedoes, depth charges or rockets in the bomb bay and under the wings. The latter also had a small radar attached to the wing.

Development of the Guardian began during the Second World War although the original request from the US Navy had been for a torpedo-bomber. At Grumman, this project was known under G-70 designation while the Navy recognized it as XTB3F and this new aircraft was to have combined powerplants with a P&W R-2800 radial engine driving a four-bladed propeller in the nose and a Westinghouse 19XB jet engine mounted in the tail section. The Westinghouse jet engine was later removed from the specification however before the maiden flight of the prototype which took place on the 19th December 1945. By this time the torpedo bomber role had become outmoded and therefore the US Navy changed its requirements for the new aircraft.

On the 24th December 1945 Grumman was asked to re configure the aircraft for the anti-submarine role but because the current AP-20 search radar was too big for a single engined aircraft to carry alongside a weapon load this would require two separate versions which would fly together, one carrying radar and the other carrying weapons. The result of this were the AF-2W and AF-2S. The prototype AF-2W (which was the radar equipped Hunter version) first flew during November 1948 and the AF-2S (Killer variant) performed its first flight in January 1949. The type also received the name 'Guardian'.

The first Guardians entered service with the US Navy in 1950 in their Hunter Killer pairs and were later joined by the improved AF-3S version which was almost identical to AF-2S but had a MAD (Magnetic Anomaly Detector) added. AF-2 and 3 Guardians flew from carriers and from land bases and during the Korean War they were responsible for protecting the US Fleet in the combat areas.

Although the type was removed from front line service during 1955 it continued in service with units of the the US Naval Reserve until 1957 and the Guardian was the first custom built specialized anti-sub aircraft to fly from US Navy carriers. It also holds the record for being the largest single engined piston engined aircraft to be flown from the decks of the US Navy.

KIT PARTS

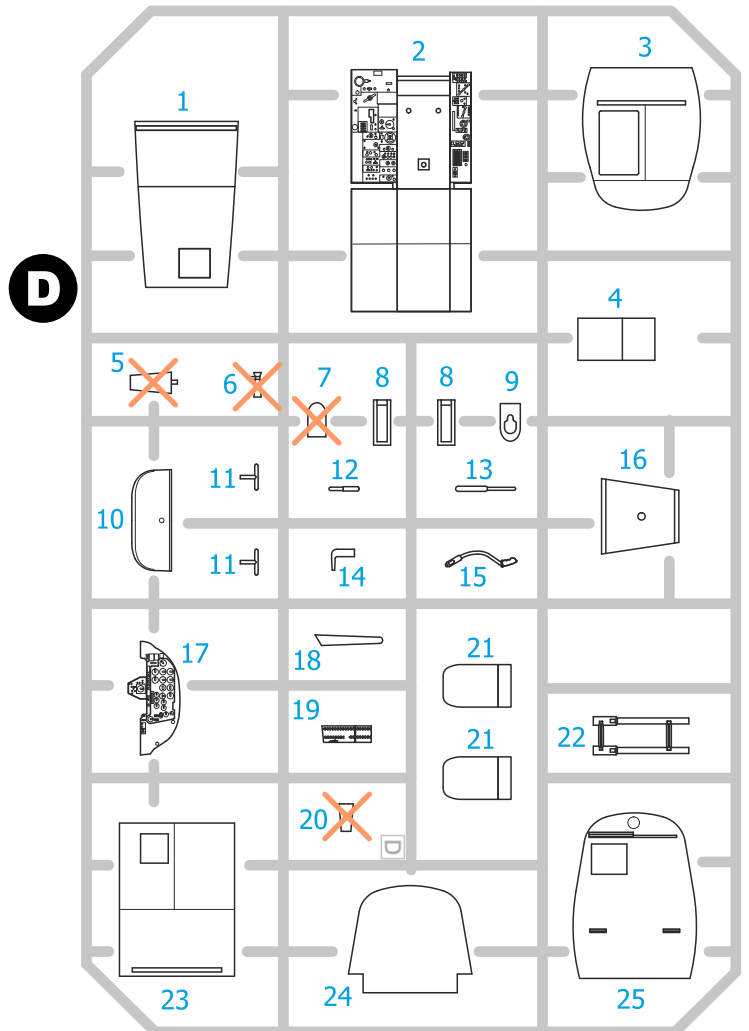
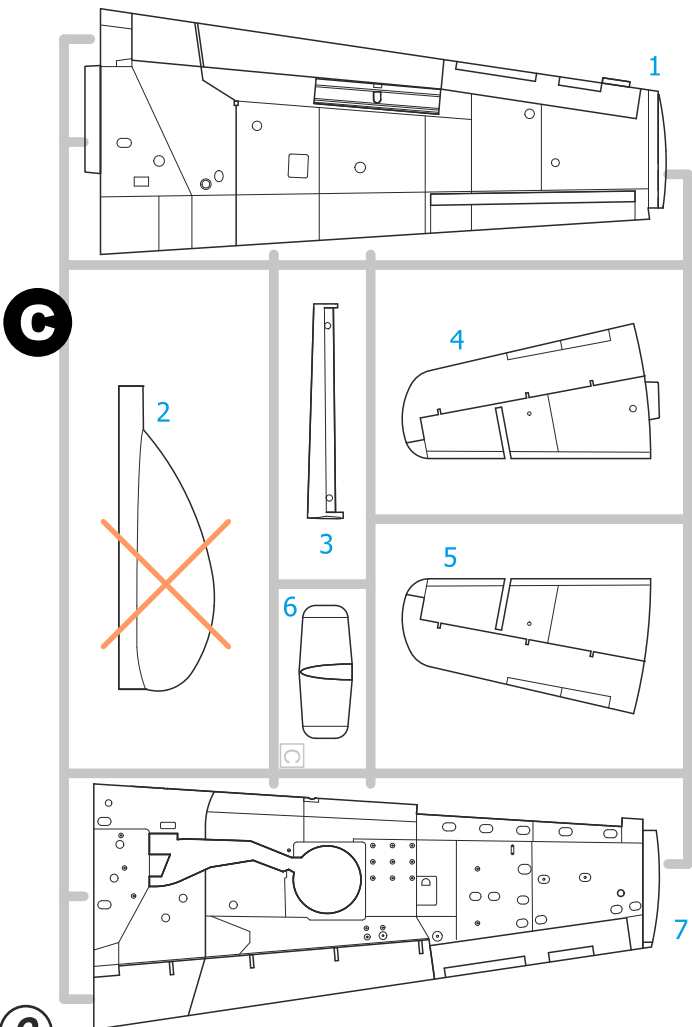
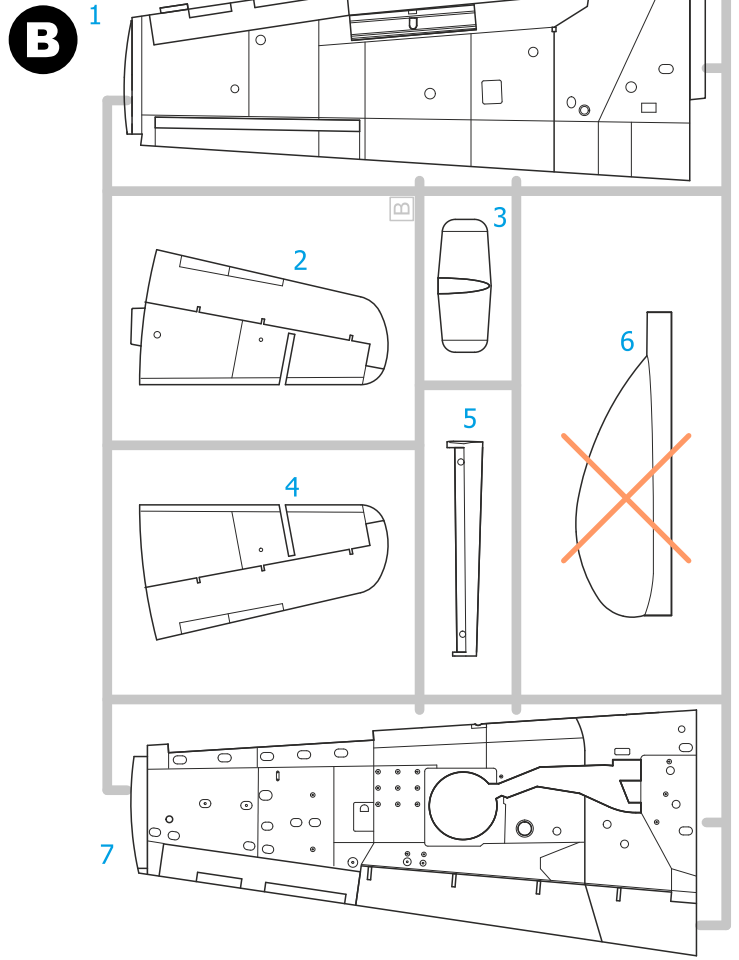
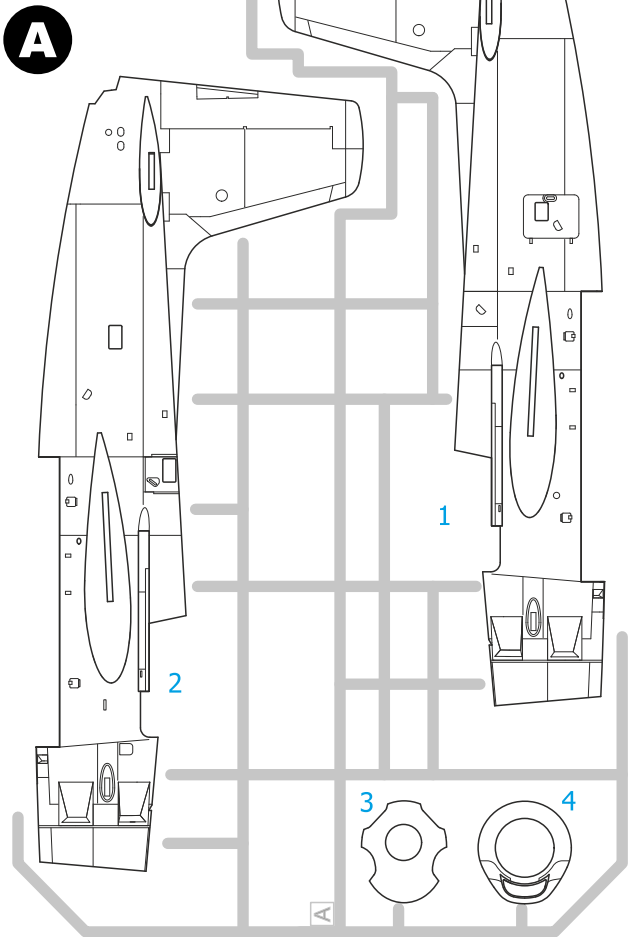

KIT PARTS

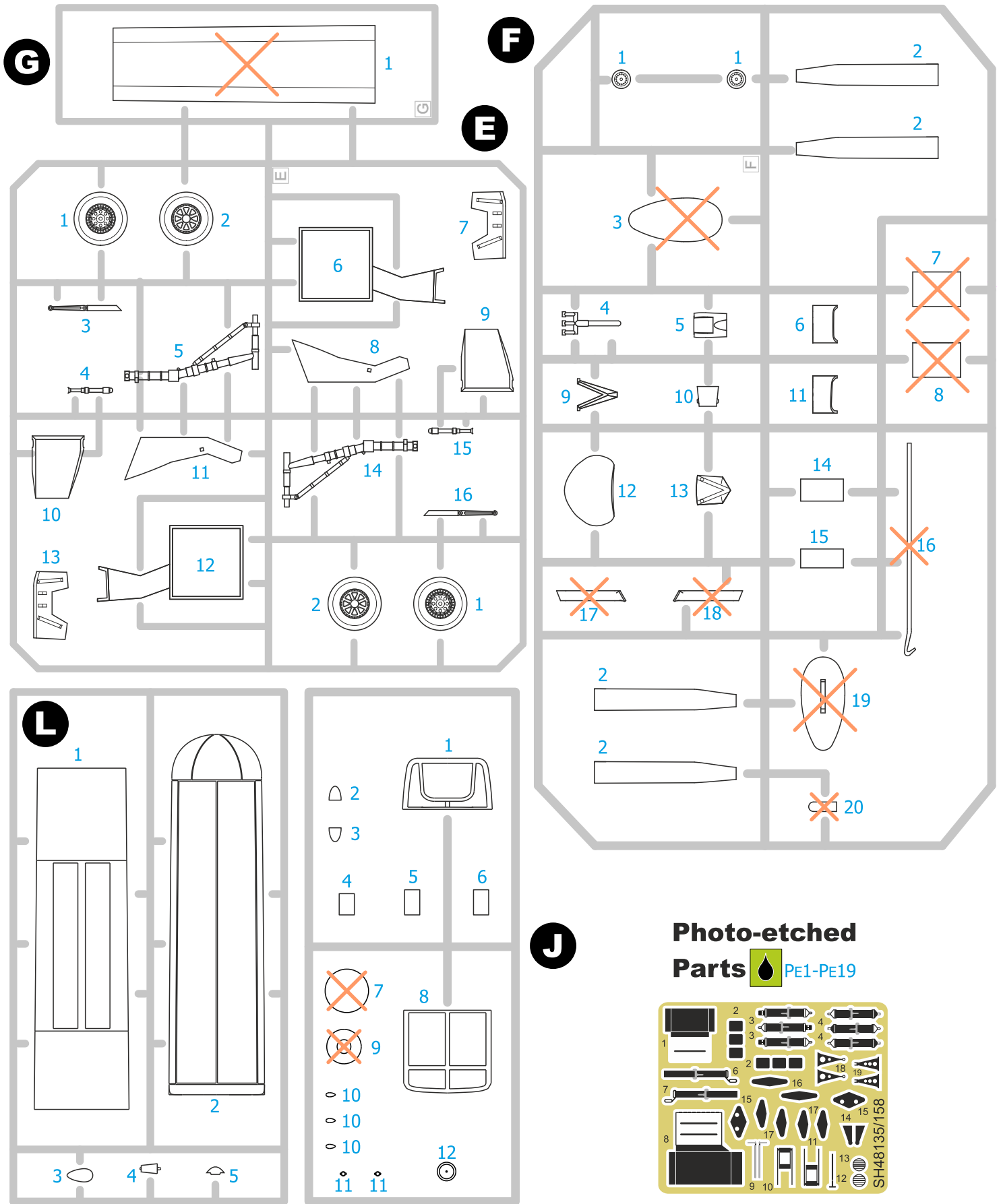

Masks trim for SCHEME A



**X Tento díl nepoužít
Do not use this part**

PUR Parts

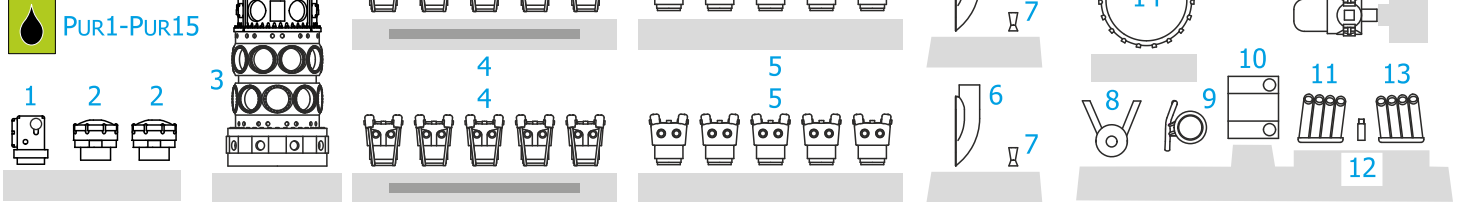

SYMBOLS

- MOŽNOST VOLBY OPTIONAL NACH BELIEBEN OPTION
- POUŽIT KYANOAKRYLÁTOVÉ LEPIDLO INSTANT CYANOACRYLATE GLUE ZYANOAKRYLÁTKLEBER ADHÉSIF CYANOACRYLAT
- OHNOUT BEND BIEGEN COURBER
- ZHOTOVIT NOVÉ SCRATCH BUILD FERTIGSTELLEN ACHEVER
- ŘEZAT/VRTAT CUT OFF/DRILL ENTFERNEN DETACHER
- GSI colours code
- NATŘÍT COLOUR FARBEN PEINDRE

ASSEMBLY

Barvy GUNZE/ GUNZE Colour No.

Off White/ špinavě bílá	H21/C69
Flat Black/matná černá	H12/C33
Aircraft Grey/letecká šedá	H57/C73
Dark Iron/tmavý kov	MC214
Tire Black/černá pneu	H77/C137
Aluminium/hliníková	H8/C8
Burnt Metal/opálený kov	H76/C61
Linen/plátno	H85/C45

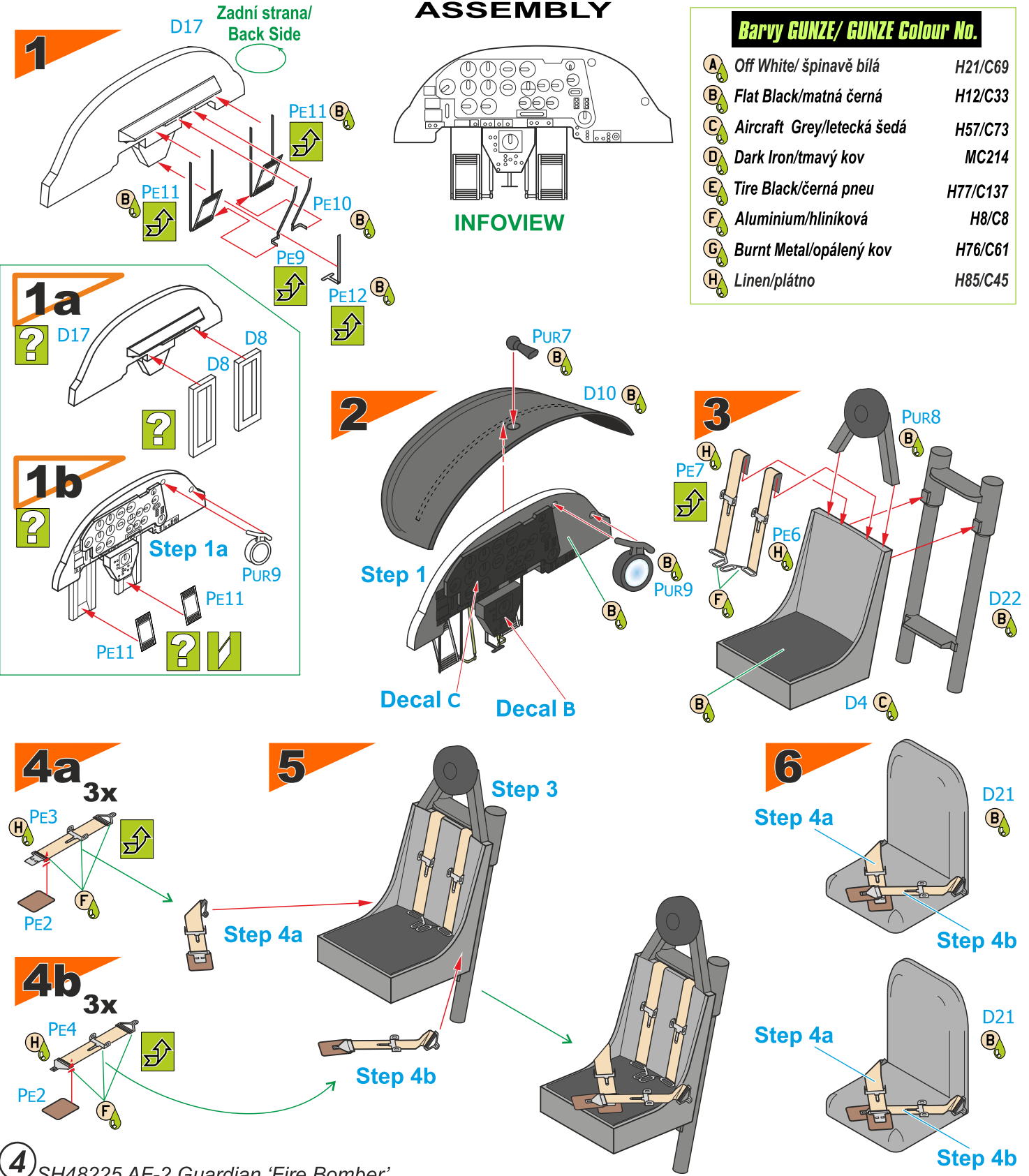

④ SH48225 AF-2 Guardian 'Fire Bomber'

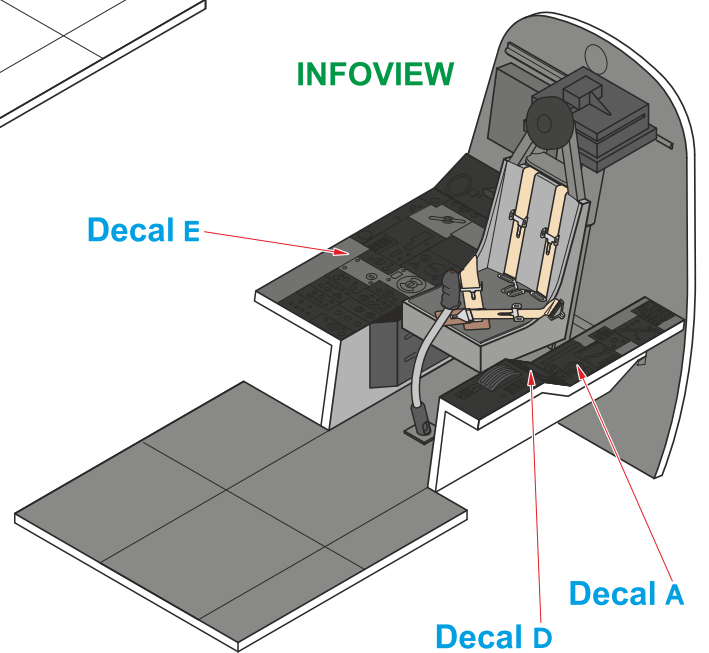
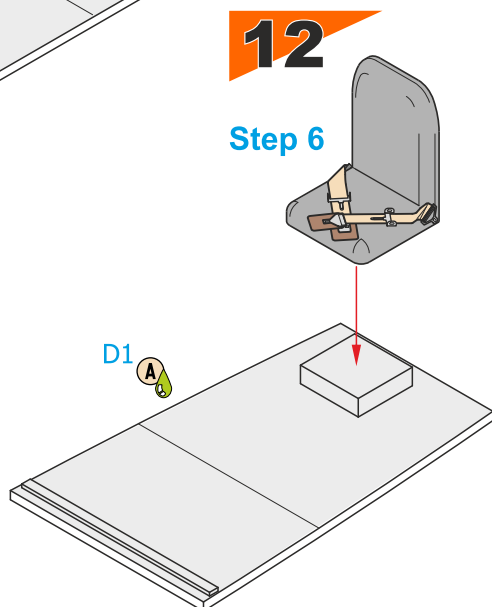
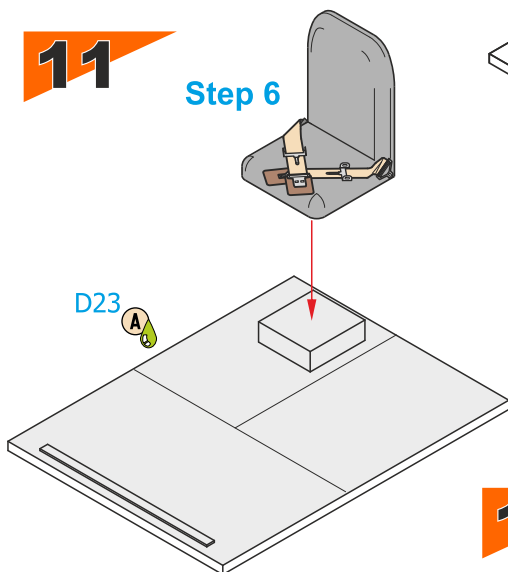
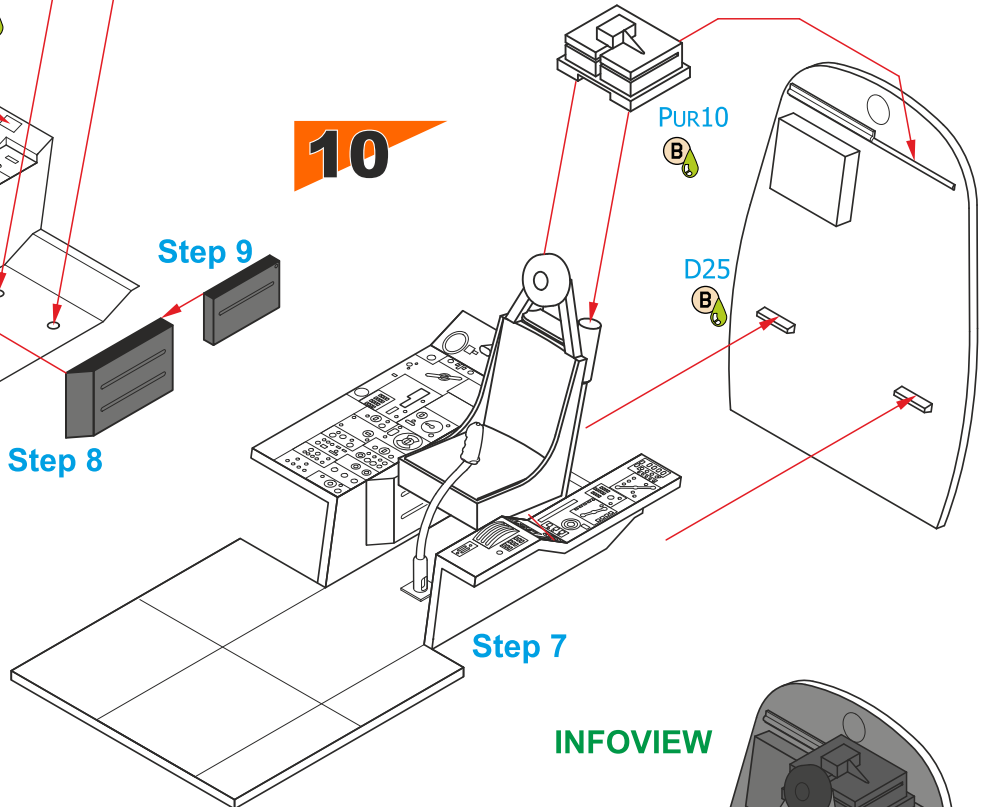
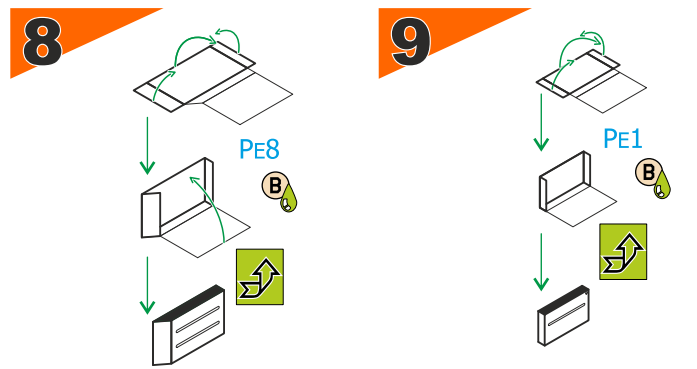
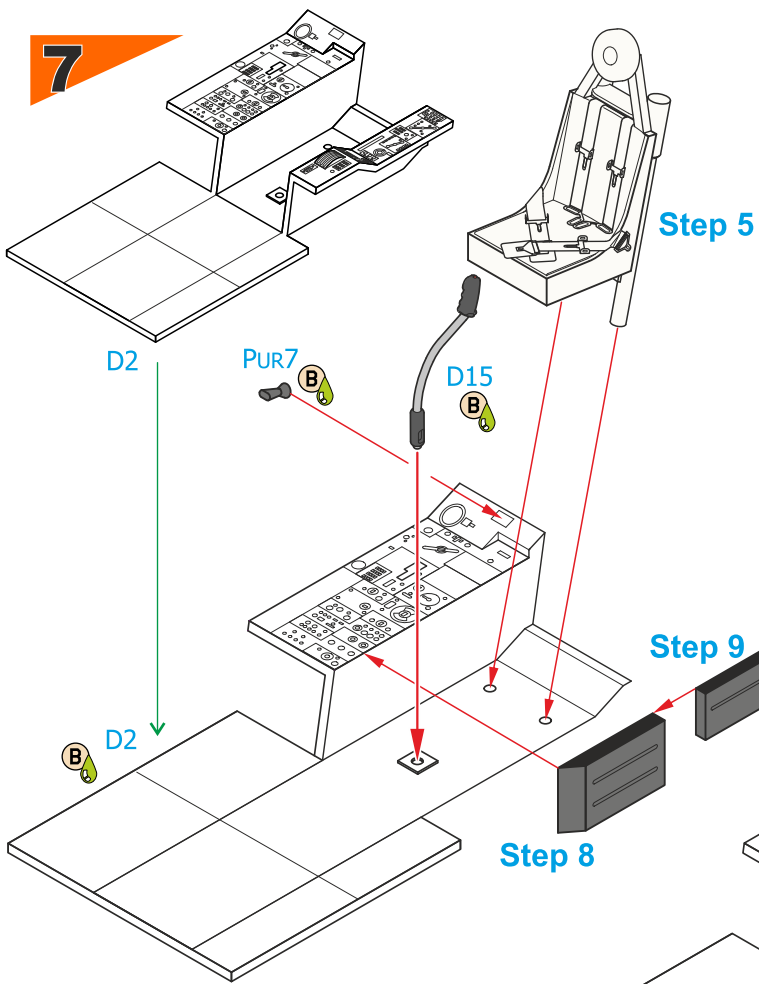

13

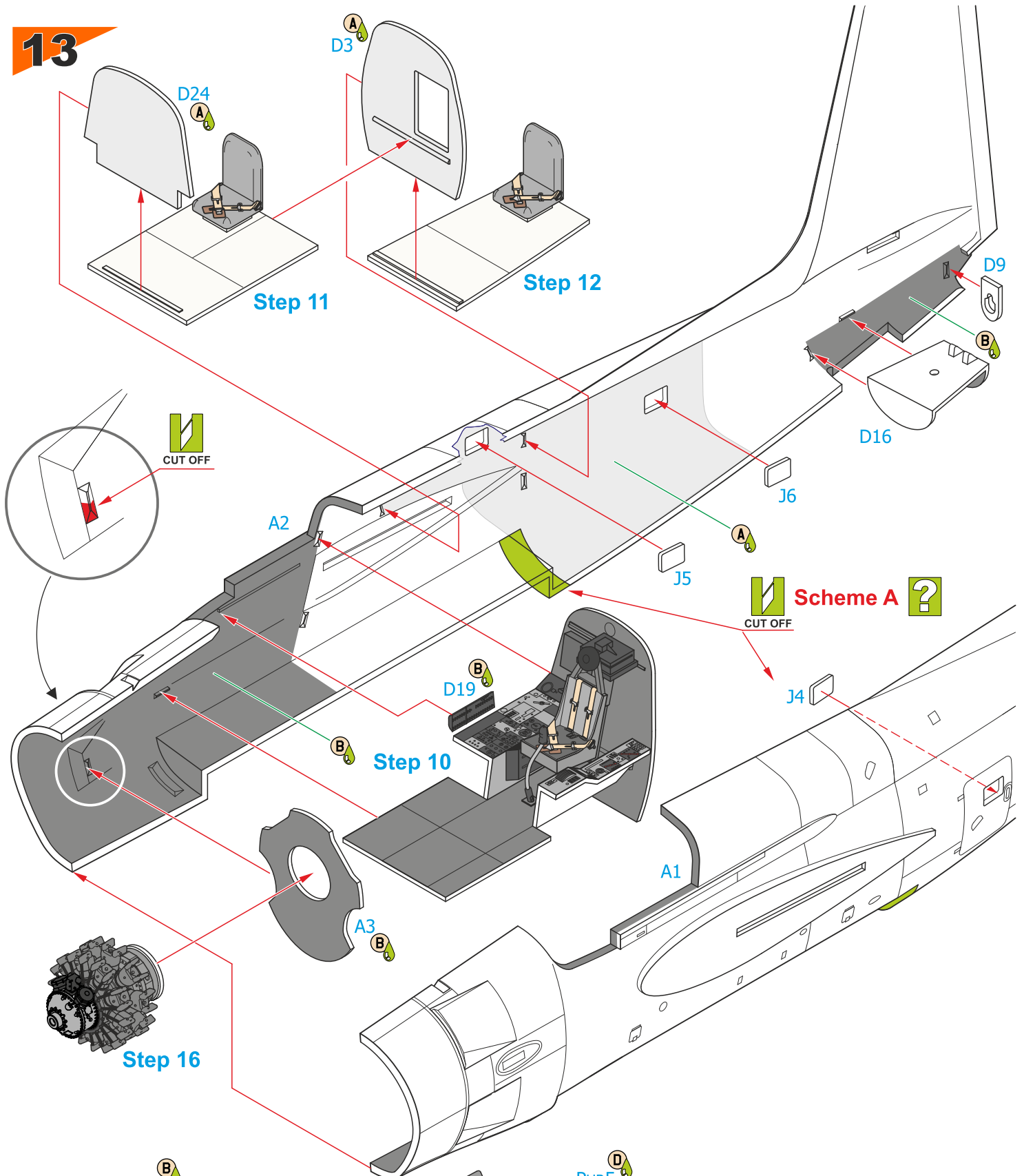

14

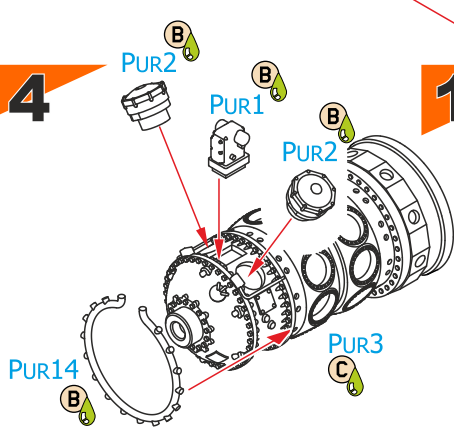

15

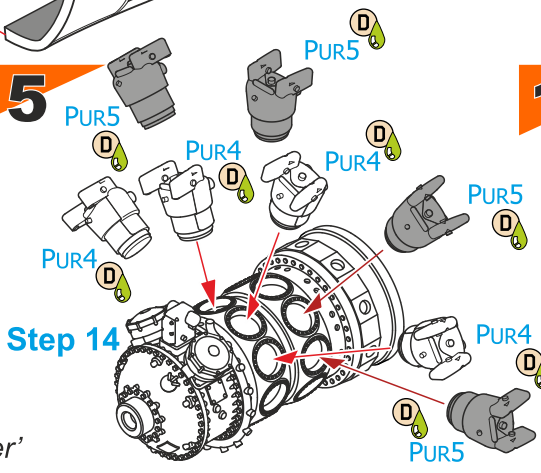

16

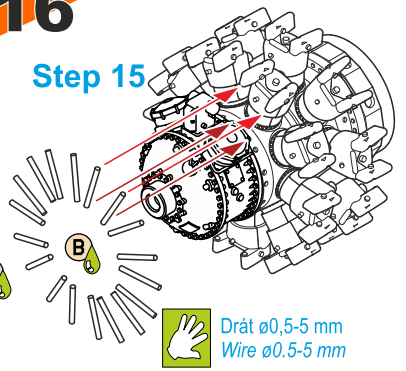

17

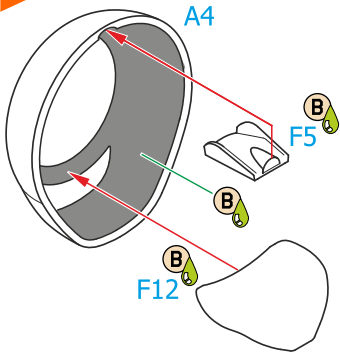

18

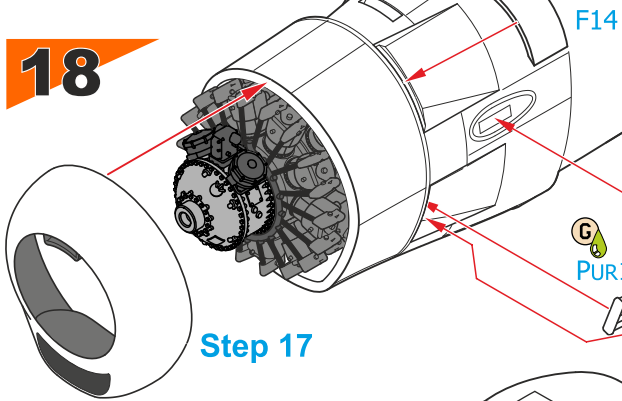

19

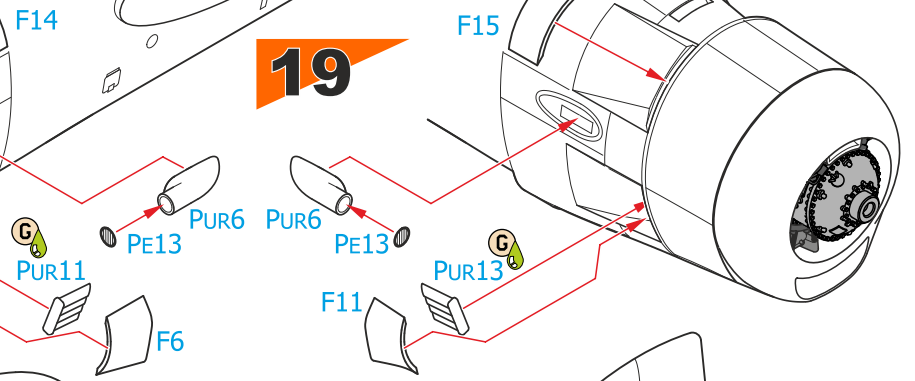

20

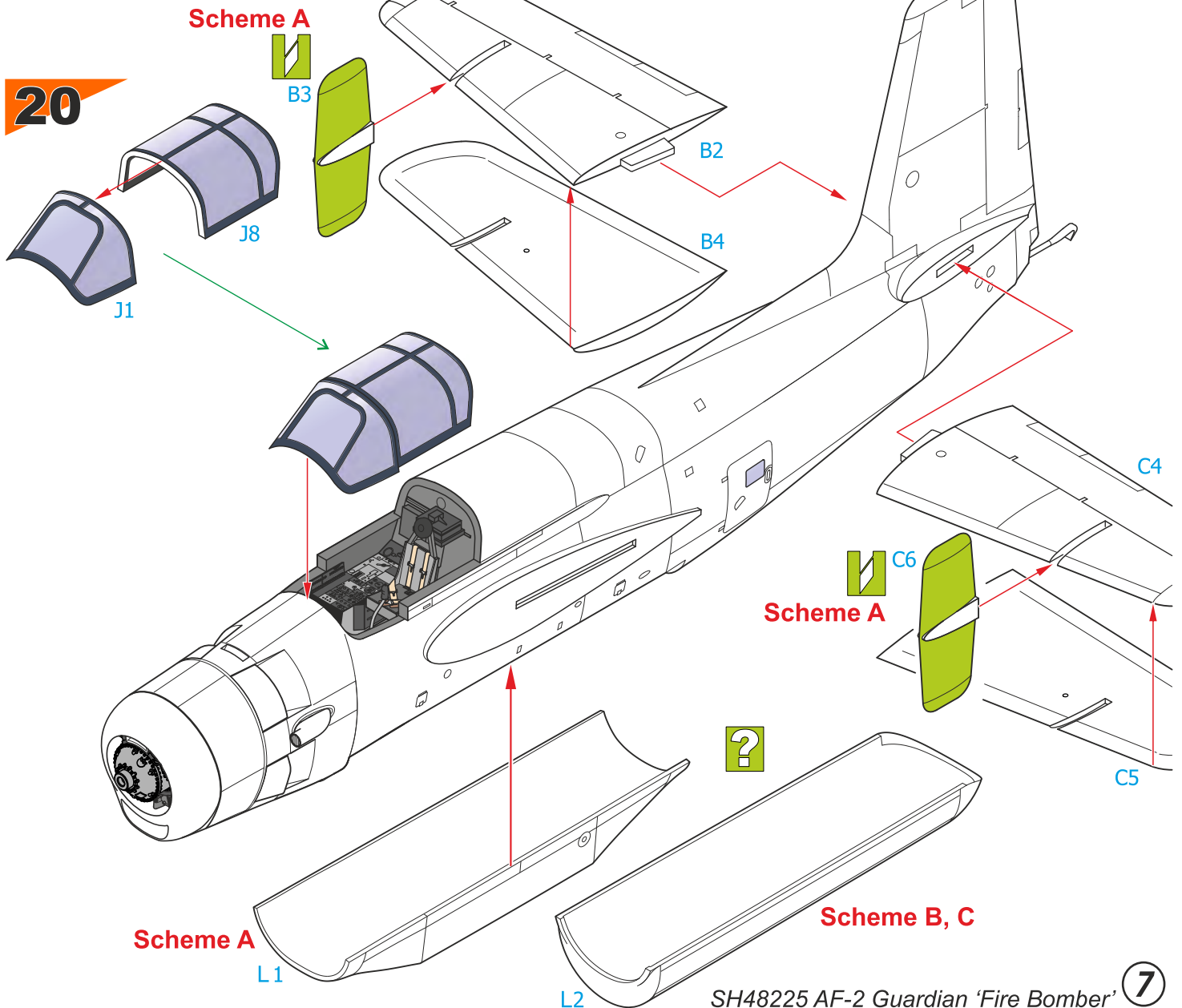

21

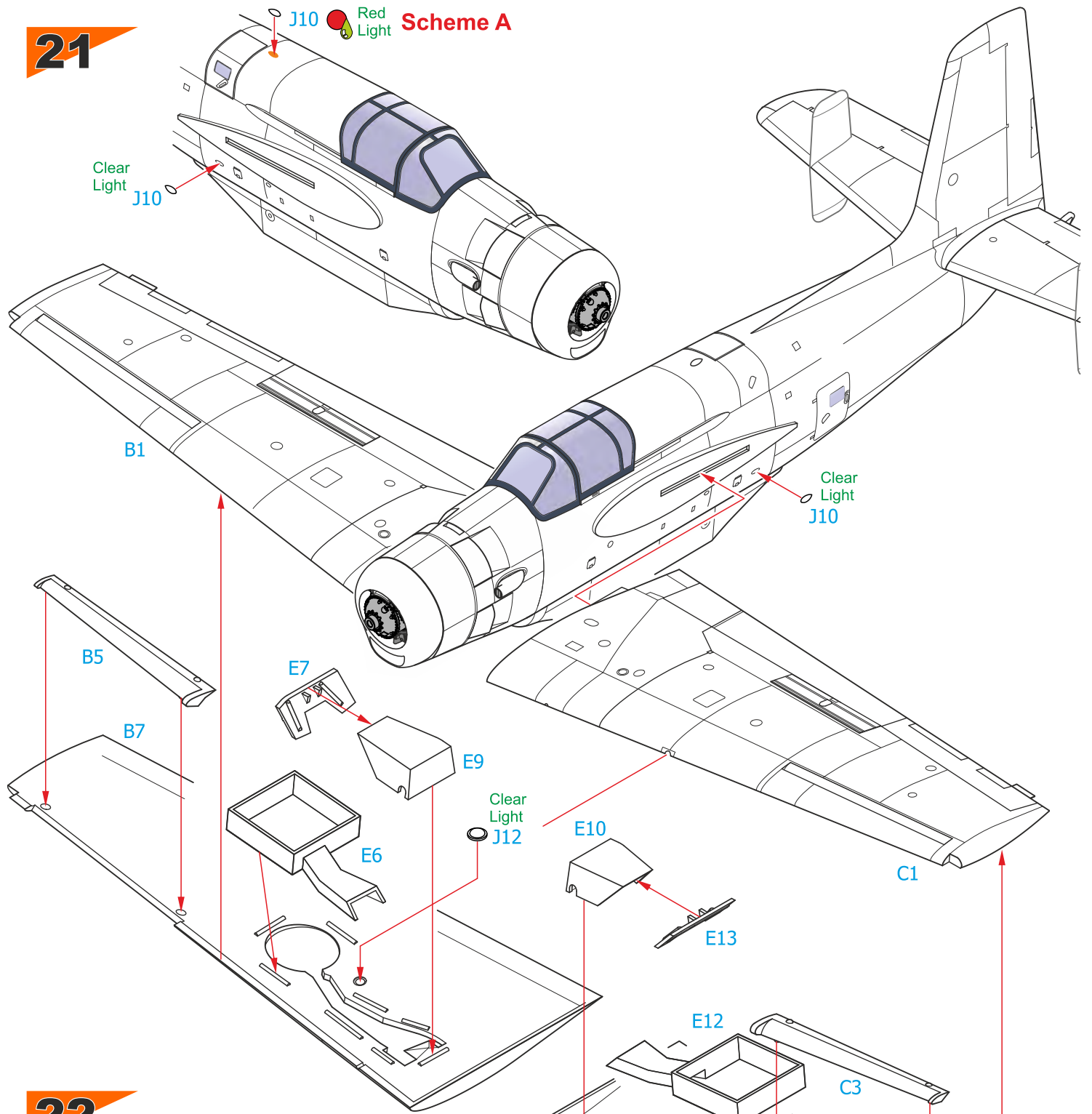

22

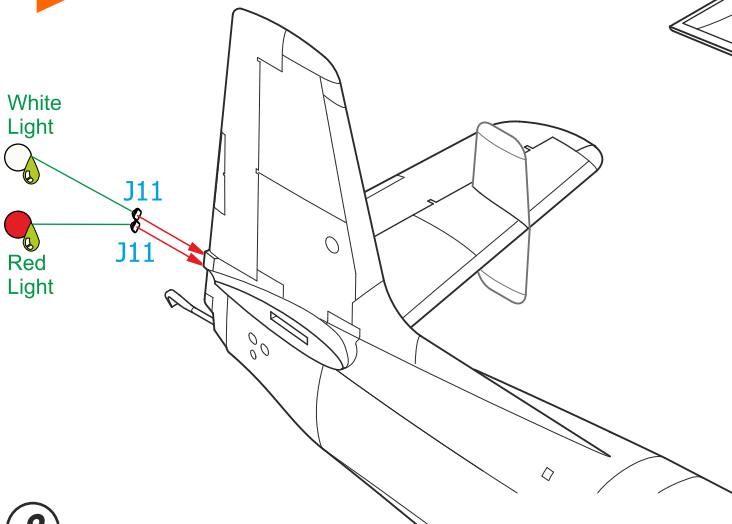

23

pohled zespoda/
view from the bottom

INFOVIEW

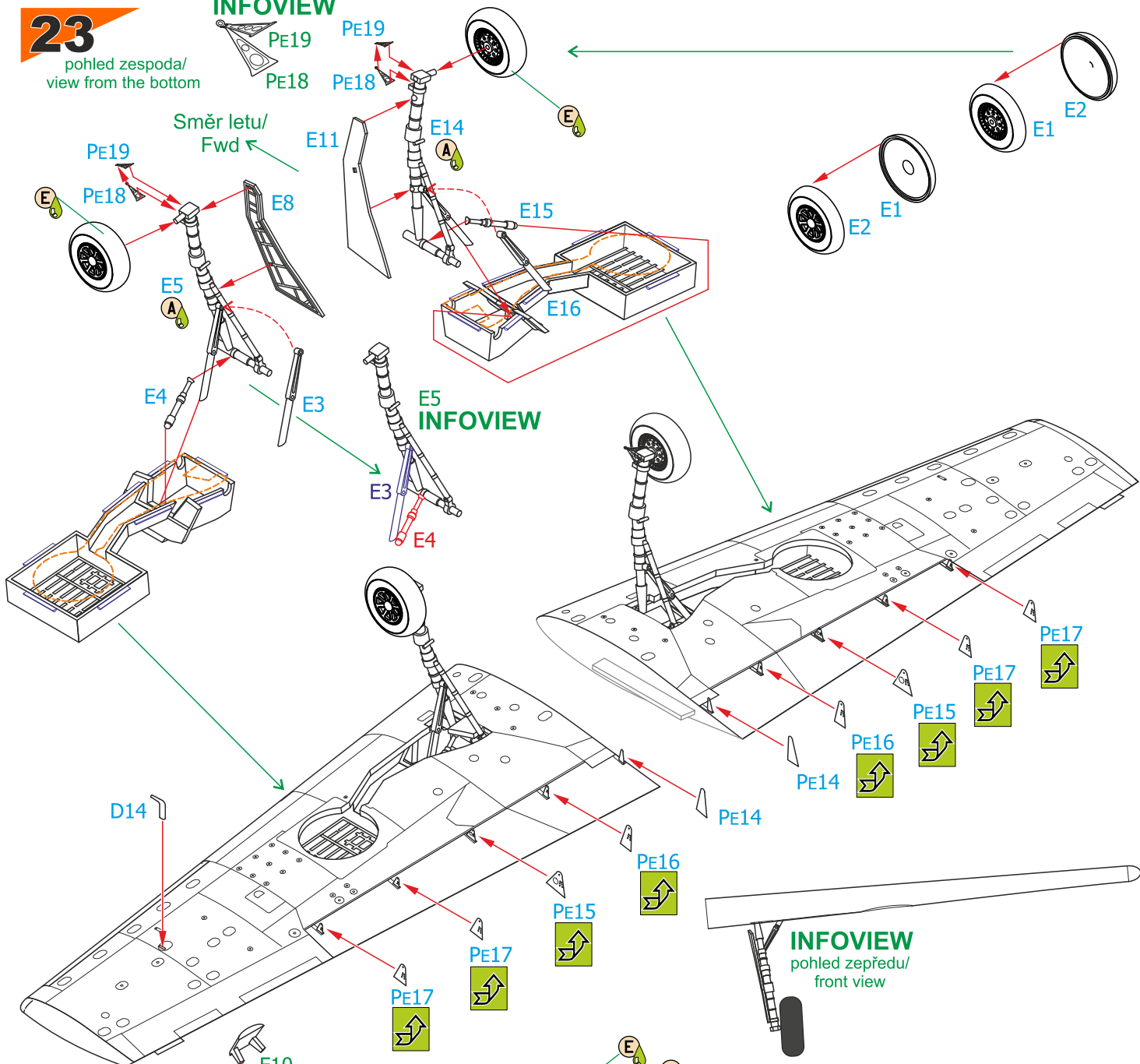

24

pohled zezadu/
rear view

INFOVIEW

Směr letu/
Fwd

pohled zezadu/
rear view

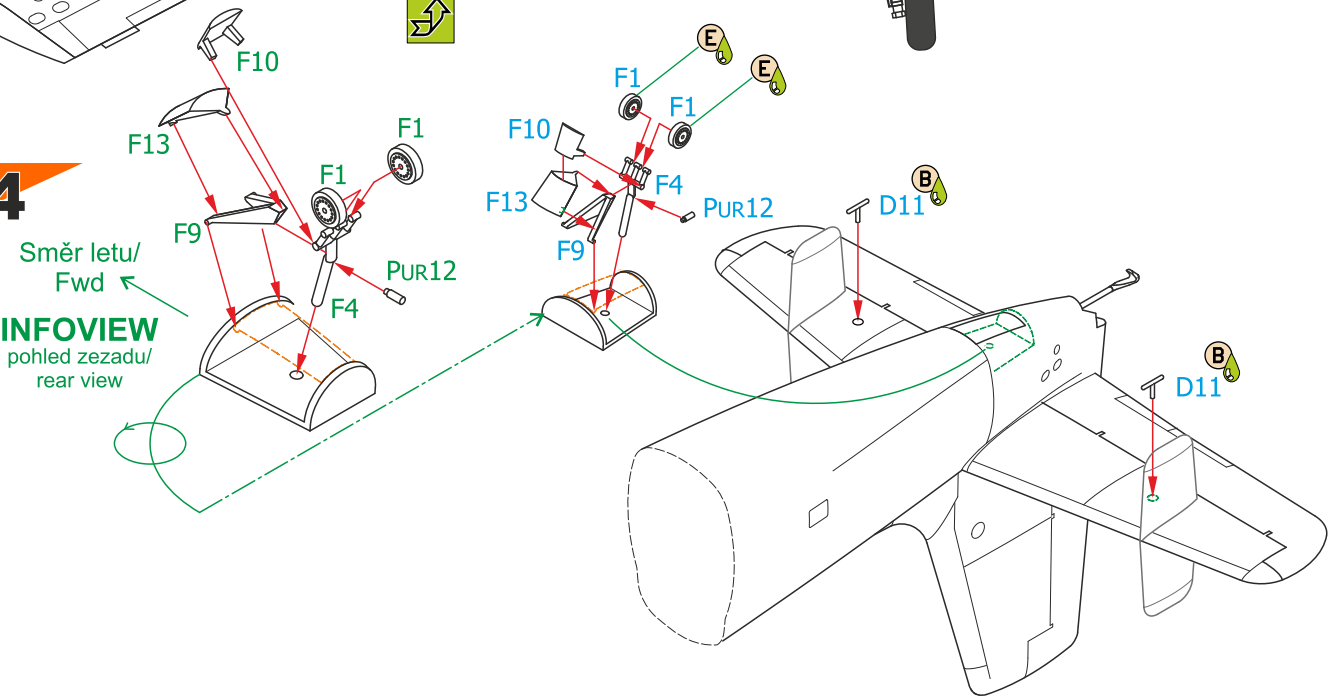

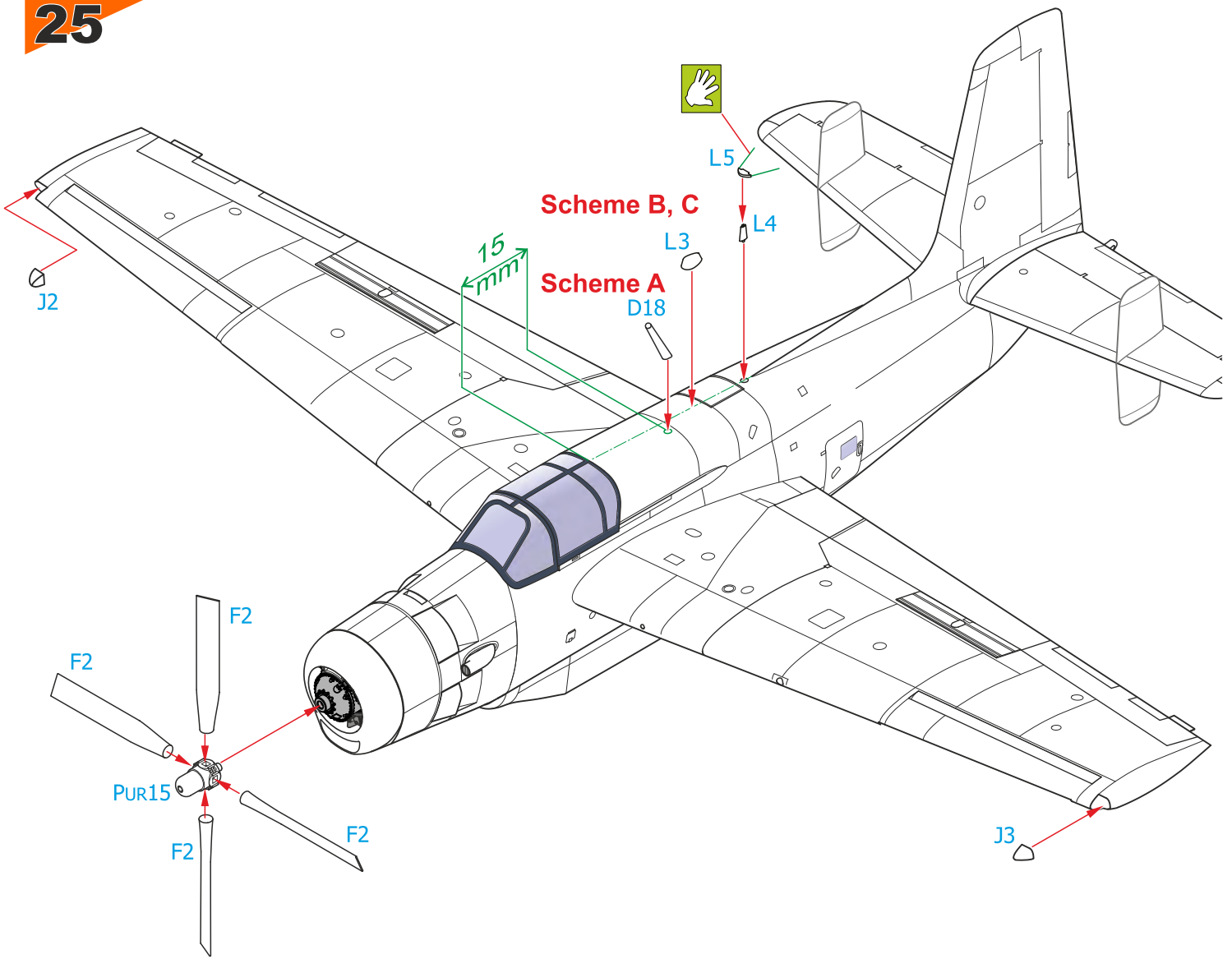

Use this!



Star Dust
weathering pigments

H1020 Razor Saw Profi Set



H1018
Triangle Razor Saw (1pc)



H1019
Multi-Shift Razor Saw (1pc)





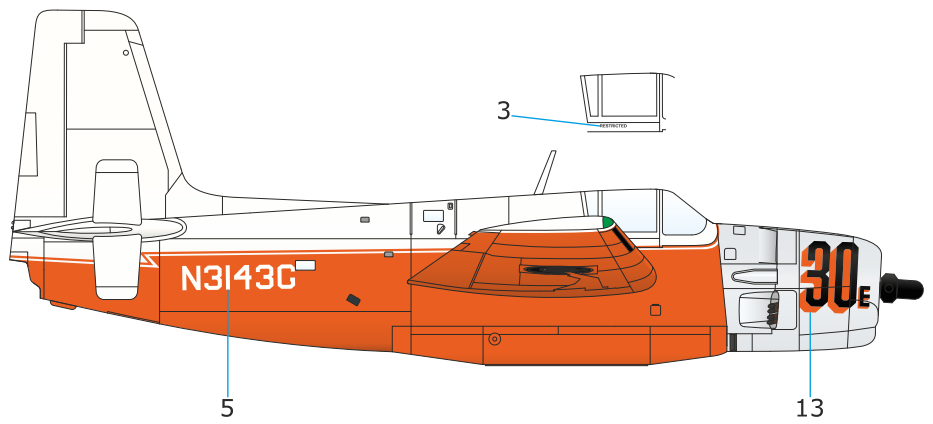
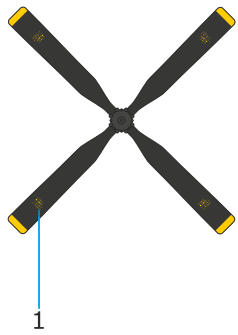

A new type handle for our razor saws.

Also contains H1018 and H1019 spare saws.



SCHEME A

-  Černá
Black
H12/C33
-  Oranžová
Orange
H14/C59
-  Bílá
White
H1/C1
-  Hliník
Aluminium
H8/C8

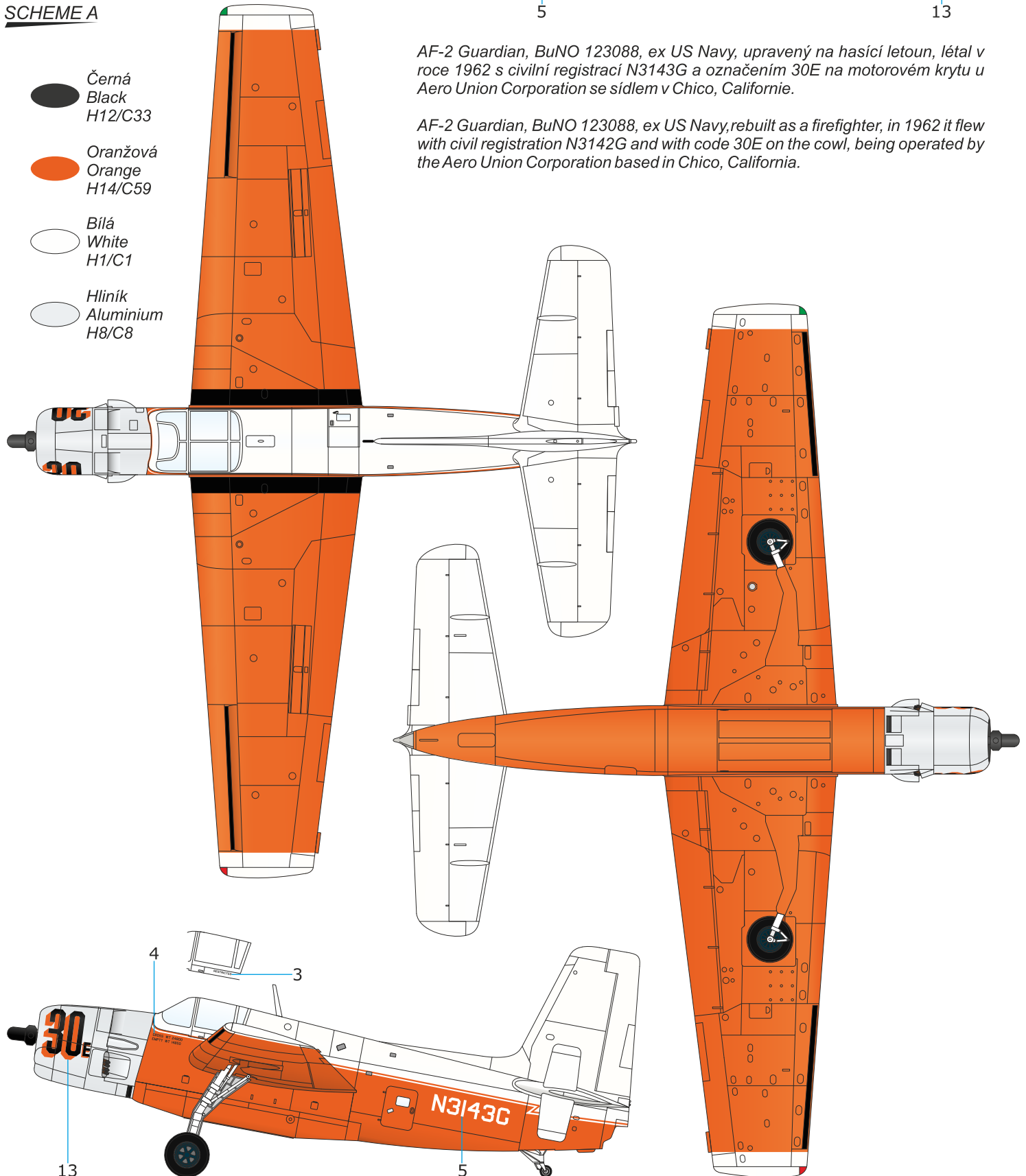

AF-2 Guardian, BuNO 123088, ex US Navy, upravený na hasičí letoun, létal v roce 1962 s civilní registrací N3143G a označením 30E na motorovém krytu u Aero Union Corporation se sídlem v Chico, Californiae.

AF-2 Guardian, BuNO 123088, ex US Navy, rebuilt as a firefighter, in 1962 it flew with civil registration N3142G and with code 30E on the cowl, being operated by the Aero Union Corporation based in Chico, California.

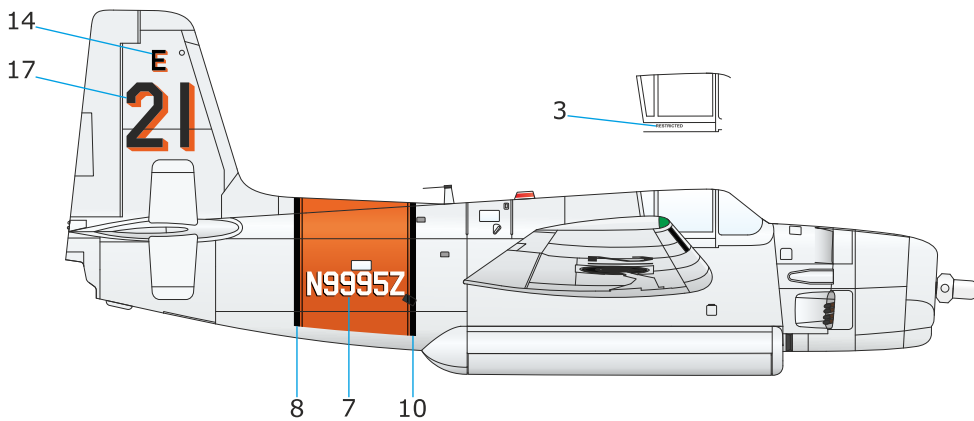
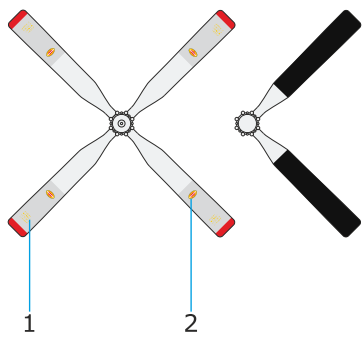

SCHEME B

-  Černá
Black
H12/C33
-  Oranžová
Orange
H14/C59
-  Hliník
Aluminium
H8/C8

AF-2 Guardian, BuNO 126792, ex US Navy, upravený na hasiči letoun, létal s civilní registrací N9995Z u Aero Union Corporation se sídlem v Chico, Californie.

AF-2 Guardian, BuNO 126792, ex US Navy, a firefighting aeroplane flying with civil registration N9995Z with the Aero Union Corporation, Chico, California.

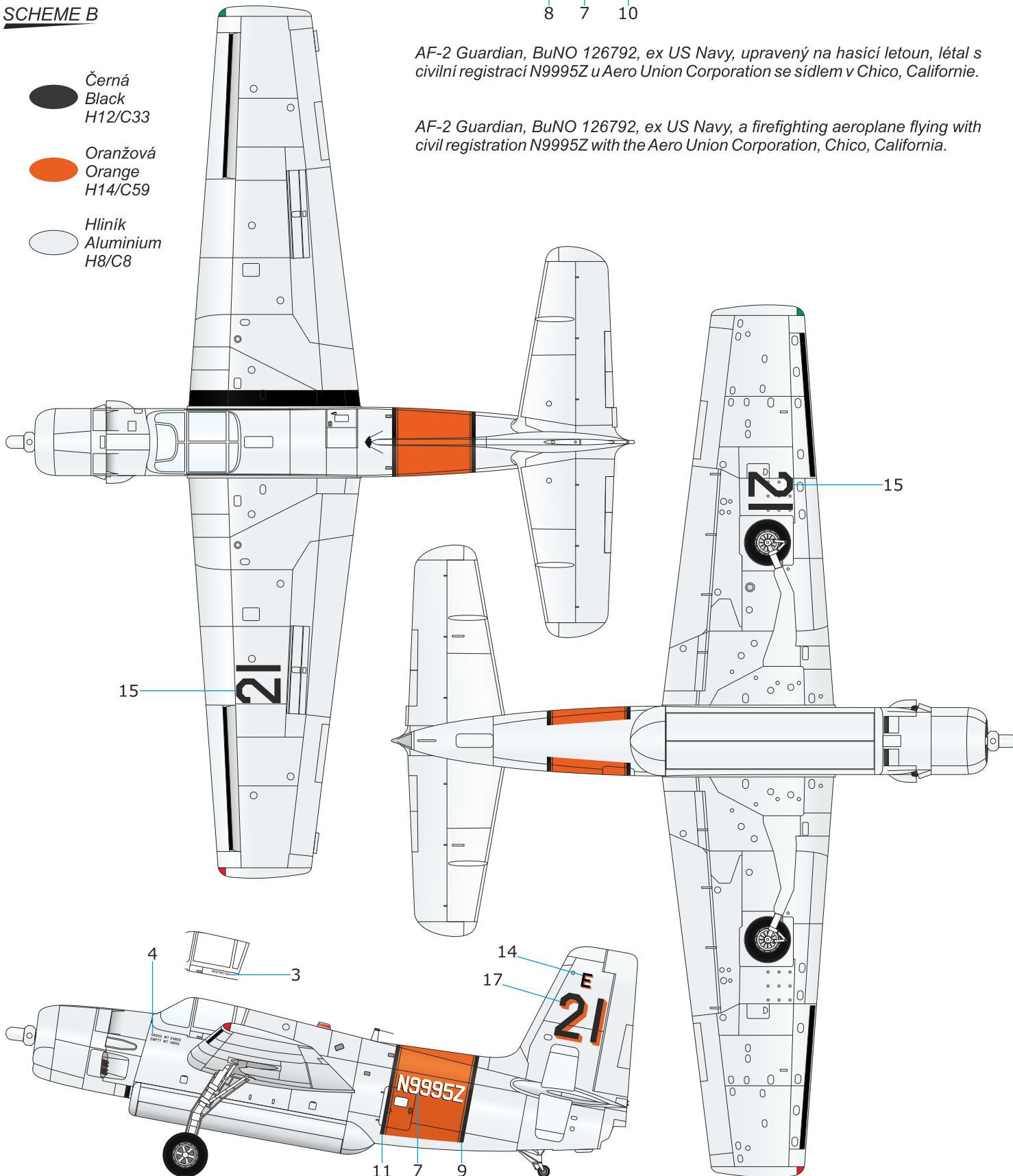

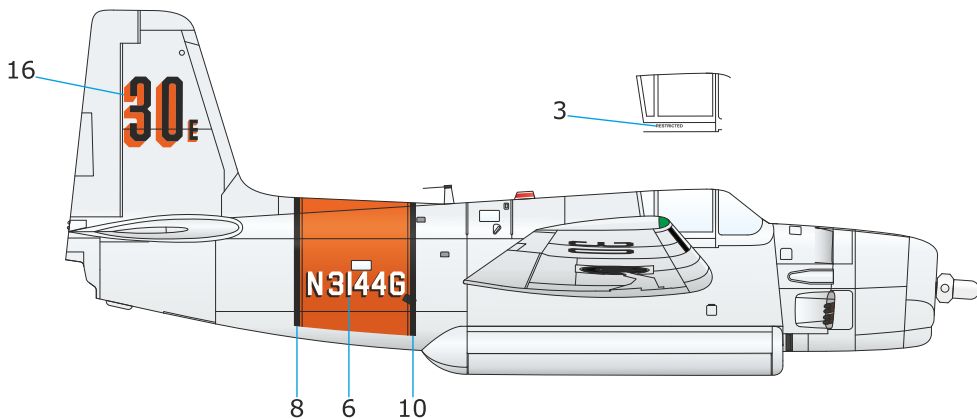
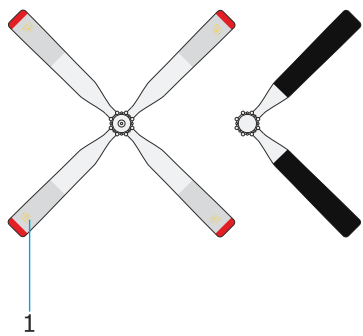

SCHEME C

-  Černá
Black
H12/C33
-  Oranžová
Orange
H14/C59
-  Hliník
Aluminium
H8/C8

AF-2 Guardian, BuNO 126759 (uváděno je jí patrně nesprávně 123100), ex US Navy, upravený na hasiči letoun, létal s civilní registrací N3144G u Aero Union Corporation se sídlem v Chico, California. V průběhu jeho služby se podoba letounu měnila. Létal i s oranžovým krytem motoru nebo s označením 30E umístěným nejen na kýlovce, ale i na motorovém krytu.

AF-2 Guardian, BuNO 126759 (sometimes incorrectly given as 123100), ex US Navy, converted to a firefighting airframe, flew with civil registration N3144G with the Aero Union Corp., Chico, California. During its service, the machine had several different finishes. At one point it had an orange coloured cowl and code 30E not just on the fin but also in the nose.

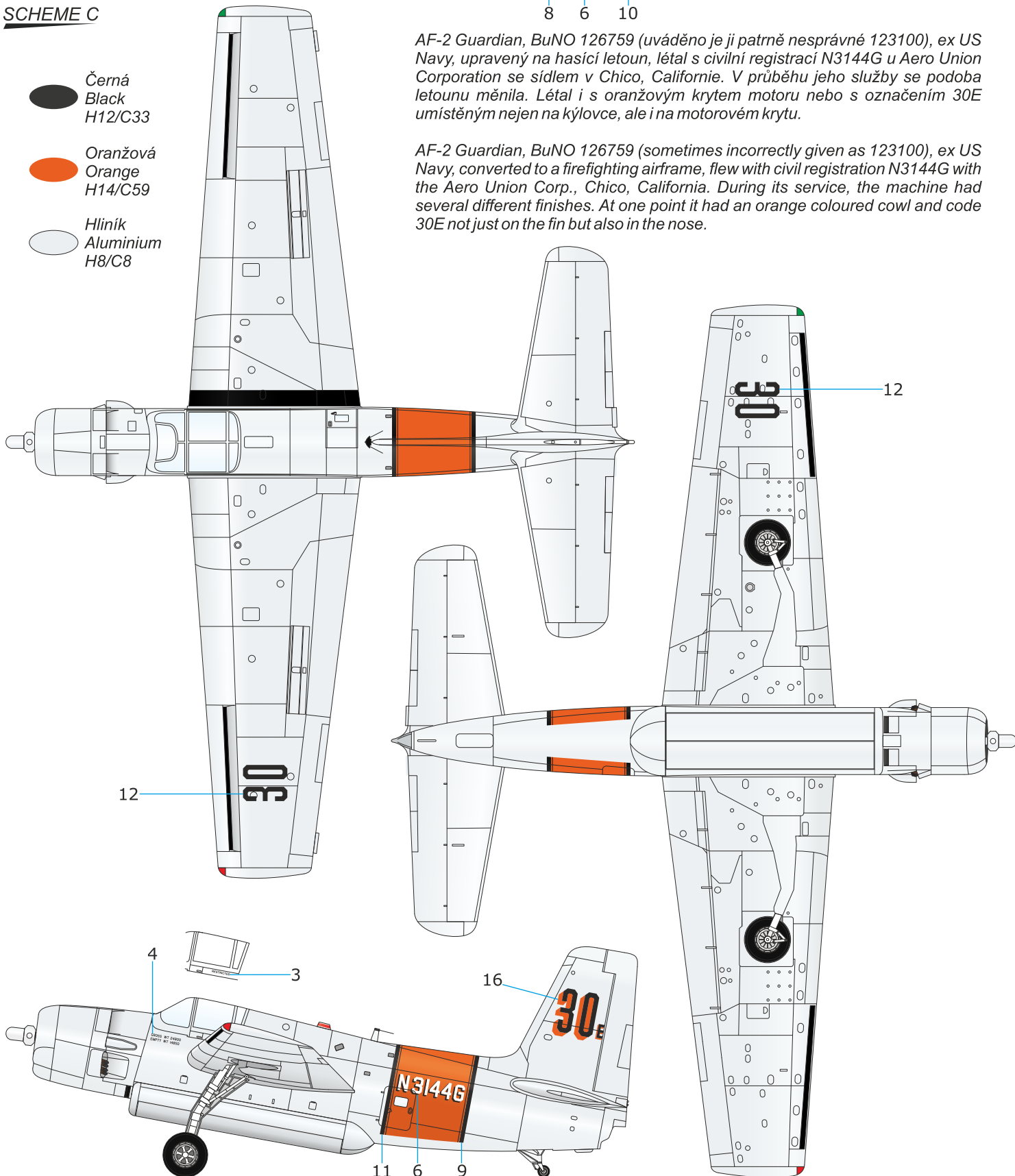

ATTRACTIVE 1/48 SCALE MODELS

SH48213



M48004
V-156F/SB2U Vindicator
MASK **Special MASK**

V-156F Vindicator 'Aéronavale Service'

SH48212



M48008
Siebel Si 204E
/Aero C-3B Bomber MASK **Special MASK**

Siebel Si 204E 'German Night Bomber & Trainer'

1/48 CMK sets for Siebel Si 204/Aero C-3 **CMK**



F48357
Mechanic
(Engine Repair)



F48358
Airman (Cleaning
Canopy Glazing)



F48359
Rigger (Prop
Maintenance)



F48367
Luftwaffe WW2 /
CS Post-War
Aircraft Mechanic



Q48352
Wheels



Q48353
Pilots' Seats



4386
Engine



Q48354
Prop Spinners



4415
German WWII Aircraft
Maintenance Toolbox

Special HOBBY

[facebook.com/specialhobby](https://www.facebook.com/specialhobby)

WWW.SPECIALHOBBY.EU | WWW.CMKKITS.COM

CMK
CZECH MASTER'S KITS

ATTRACTIVE 1/48 SCALE MODELS & SETS



SH48148
SAAB AJ 37 Viggen 'Attack Version'

CMK resin sets for Viggen

129-4310

Bofors m/70
Rocket Pod (2 pcs.)

129-Q48219

SAAB 37 Viggen
Ejection Seat

129-Q48220

AAB 37 Viggen
Air Brakes Set

129-Q48221

SAAB 37
Viggen Wheels

129-Q48222

SAAB 37 Viggen
Thrust Reverser

129-4361

AJ-37/SF-37/SH37 Viggen
Canard Correction Set

129-4362

JA-37 Viggen
Canard Correction Set



**AH-1G
COBRA**
'Over Vietnam
with M-35
Gun System'

Hi-Tech kit

Hi-Tech release contains also these extra parts:

3D-printed parts



PLU parts

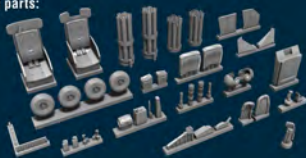

Photo-etching parts



Masks



SH48230



129-8054
MA-1A USAF Start Cart /RESIN KIT/



129-8058
MD-3 Ground Power Unit /RESIN KIT/



129-F48103
Vietnam LRRP US
Helicopter crew (2 fig.)



129-4268
MD-500E/OH-6DA
Conversion set for Hasegawa kit

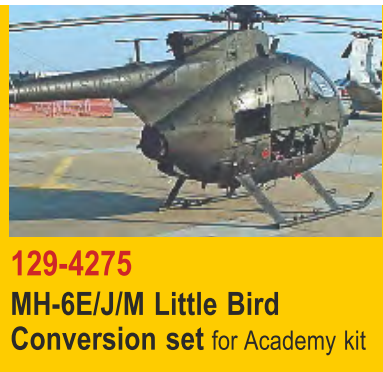

129-4275
MH-6E/J/M Little Bird
Conversion set for Academy kit



129-4276
AH-6F/J Attack version
Conversion set for Academy kit

ATTRACTIVE 1/48 SCALE MODELS & SETS

V-173 Flying Pancake 1/48 SH48121



L-4 Grasshopper 'From Africa to Central Europe' 1/48 SH48218



RESIN SETS & MASKS
for L-4 Grasshopper

M48007
L-4 Grasshopper
Inside/Outside MASK



4452
Main Wheels



P48002
Engine



H1020 Razor Saw Profi Set



H1018
Triangle Razor Saw (1pc)



H1019
Multi-Shift Razor Saw (1pc)



Also contains H1018 and H1019 spare saws.



facebook.com/specialhobby | WWW.SPECIALHOBBY.EU | WWW.CMKKITS.COM

