

T-2 Buckeye **'Anniversary Markings'**

Historie

CZ

Od roku 1959, kdy vstoupil do služby, až do roku 2004, kdy byl North American T-2 Buckeye vyřazen z výcvikového programu, byl prvním proudovým strojem námořnictva USA, na kterém létali do výcviku zařazení letci. US Navy objednalo tento letoun v roce 1956, s tím, že v rámci několikastupňového výcviku bude zařazen za vrtulový T-28 Trojan. Sloužil k seznámení s proudovou technikou před přechodem na bojové stroje.

První prototyp označený YT-2J-1 vzletl 31. 1. 1958. První verze T2J-1 byla jednomotorová. Poháněl ji motor J34-WE-48. Této verze bylo postaveno 201 kusů, od roku 1962 byla v novém systému označování přeznačena na T-2A.

US Navy požadovalo úpravu na dvumotorový stroj s větší bezpečností. Proto North American připravil a zavedl do výroby verzi T-2B se dvěma motory J60-P-4. Postaveno bylo 97 kusů, poté výroba přešla na verzi T-2C s motory J85-GE-4.

Té bylo postaveno 231 kusů. Bojové jméno společné pro všechny verze bylo Buckeye - jírovec neboli kaštan.

T-2 Byly vyráběny v Columbusu v Ohiu a jírovec je státním stromem státu Ohio. Na konci své služby u US Navy byla část strojů upravena na terčové a označena DT-2B nebo DT-2C.

Kromě toho, že T-2 sloužily skoro padesát let k výcviku letců US Navy, byly také exportovány. Verzi označovanou T-2D odebralo letectvo Venezuely, T-2E složí v Řeckém vojenském letectvu.

V USA nyní létá několik T-2 jako soukromé jety.

rozpětí: 11,6 m, délka: 11,8 m, max. rychlost v úrovni moře: 862 km/h, dolet: 1723 km, dostup: 13 045 m

History

EN

North American T-2 Buckeye was the first US Navy jet trainer aircraft since 1959 when it entered service until 2004 when it was withdrawn from pilots' training program. It was ordered by the US Navy in 1956 as intermediate trainer for training conversion from T-28 Trojans. It served for jet powered aircraft familiarization prior conversion to combat aircraft.

The first prototype YT-2J-1 took off on January 1, 1958. The first version T2J-1 was powered by single J34-WE-48 jet engine. 201 machines of this version were produced and since 1962 when new designation system was introduced the aircraft was re-designated to T-2A.

For better safety the US Navy demanded the aircraft to be powered by two jet engines. Therefore North American designed and introduced T-2B version powered by two J60-P-4 jet engines. 97 machines of this version were produced and then the production switched to T-2C version powered by two J85-GE-4 jet engines.

T-2C was produced in 231 pieces. The combat name common to all versions was Buckeye - Ohio chestnut tree. T-2s were produced in Columbus Ohio and the buckeye is the Ohio's state tree. At the end of its career some US Navy machines were converted for target towing and re-designated DT-2B or DT-2C.

Except of the fact that T-2s served for training almost half a century they were also exported. T-2D was purchased by the Venezuelan Air Force; T-2E still serves with the Hellenic Air Force.

Several T-2s are in private hands in the USA.

Wingspan: 11.6 m, Length: 11.8 m, Max. Speed at sea level: 862 km/h, Range: 1,723 km,
Service Ceiling: 13,045 m.

PLASTIC Parts

A

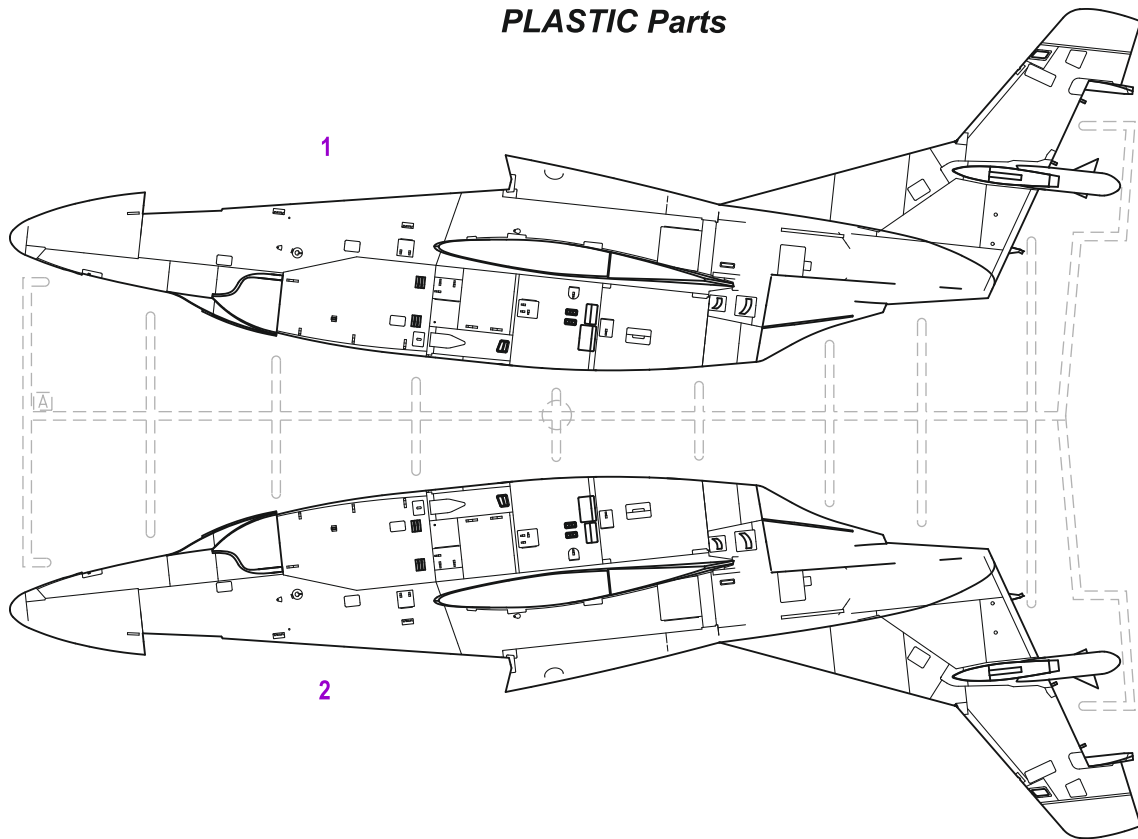

B

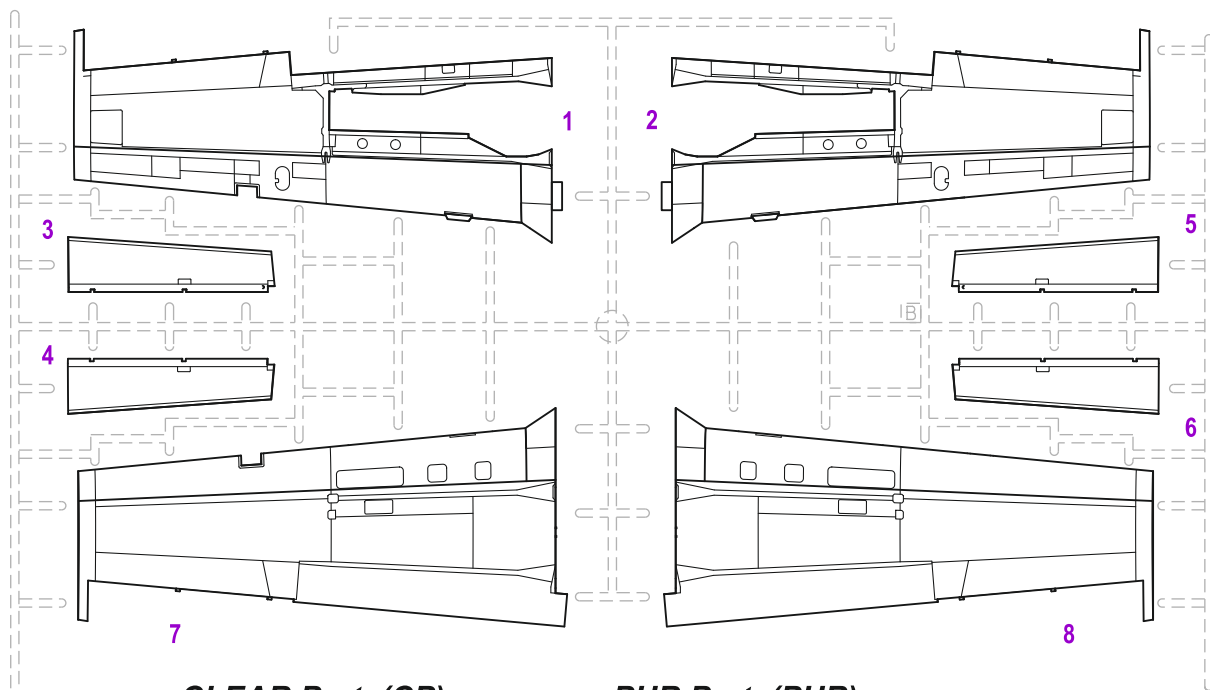

CLEAR Parts(CP)

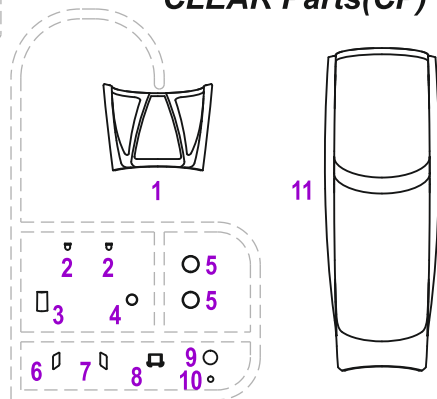

PUR Parts(PUR)

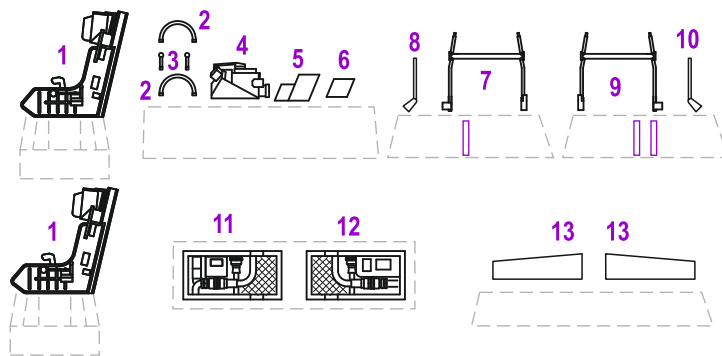

SYMBOLS



MOŽNOST VOLBY
OPTIONAL
NACH BELIEBEN
OPTION



POUŽIT KYANOAKRYLÁTOVÉ LEPIDLO
INSTANT CYANOACRYLATE GLUE
ZYANOAKRYLÁTKLEBER
COLLE CYANOACRYLAT



OHNOUT
BEND
BIEGEN
COURBER



ZHOTOVIT NOVÉ
SCRATCH BUILD
FERTIGSTELLEN
ACHEVER



ŘEZAT/VRTAT
CUT OFF/DRILL
ENTFERNEN
DETACHER

GSI **A**
colour code

NATRÍT
COLOUR
FARBEN
PEINDRE

PLASTIC Parts

C

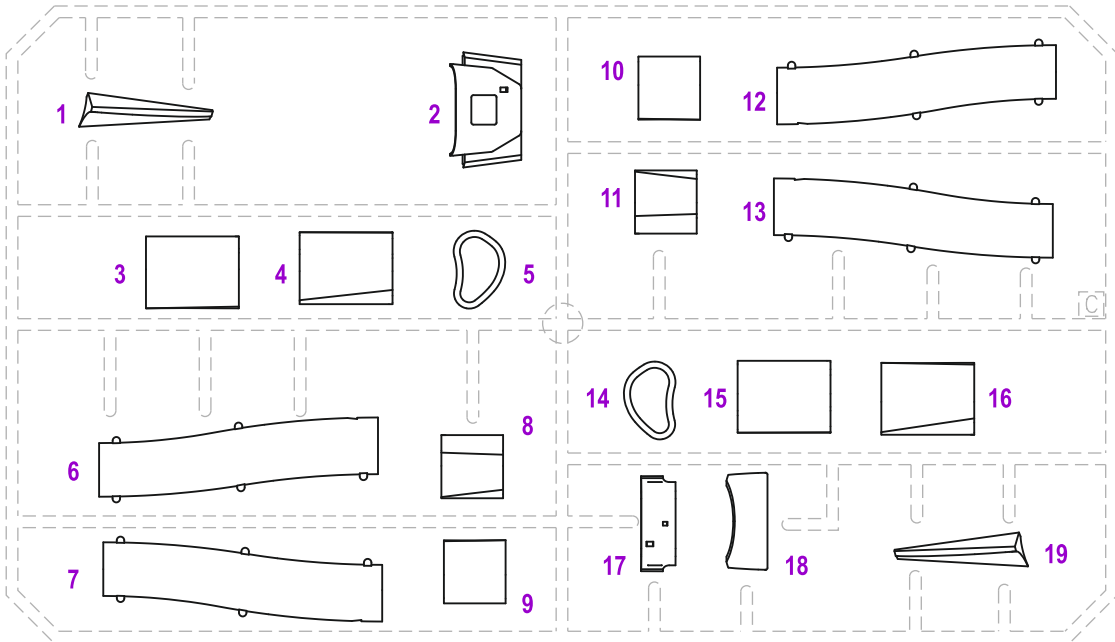

D

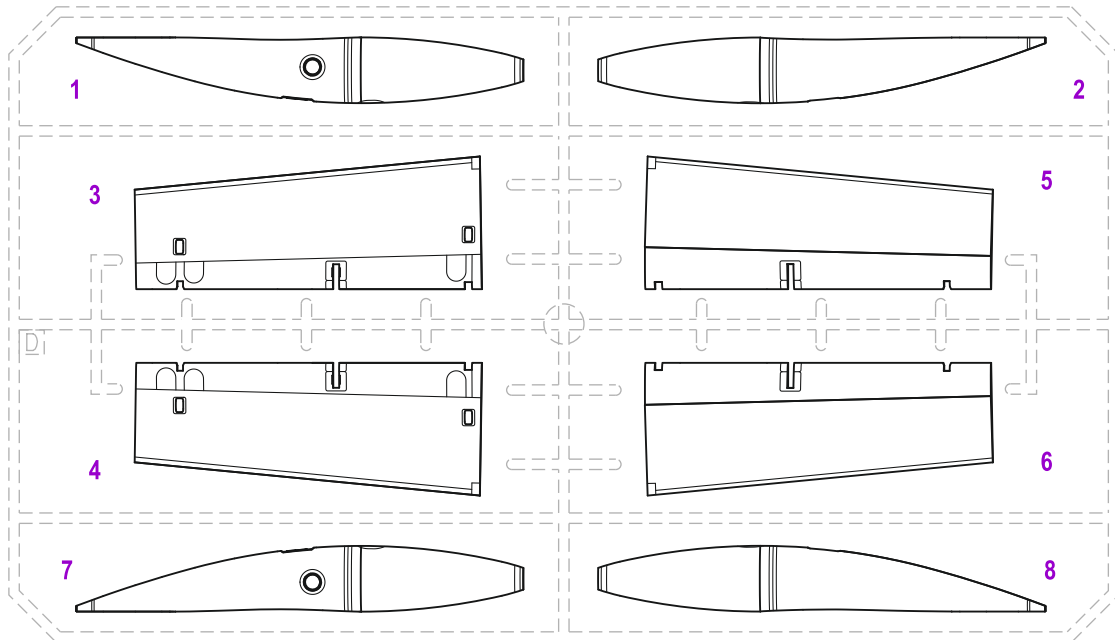

E

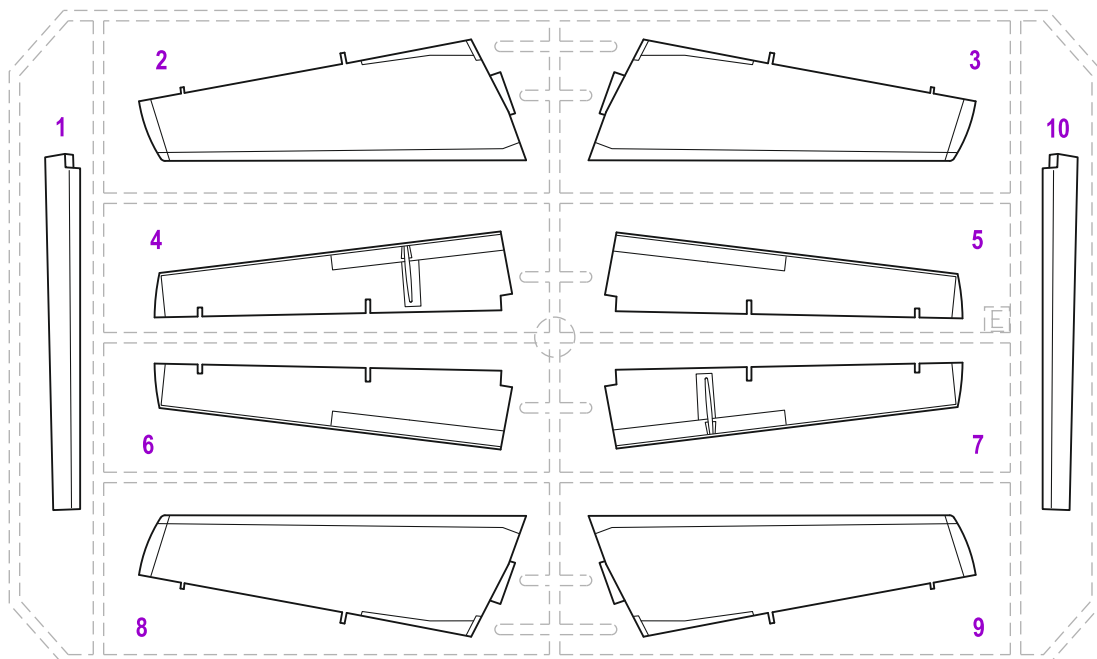

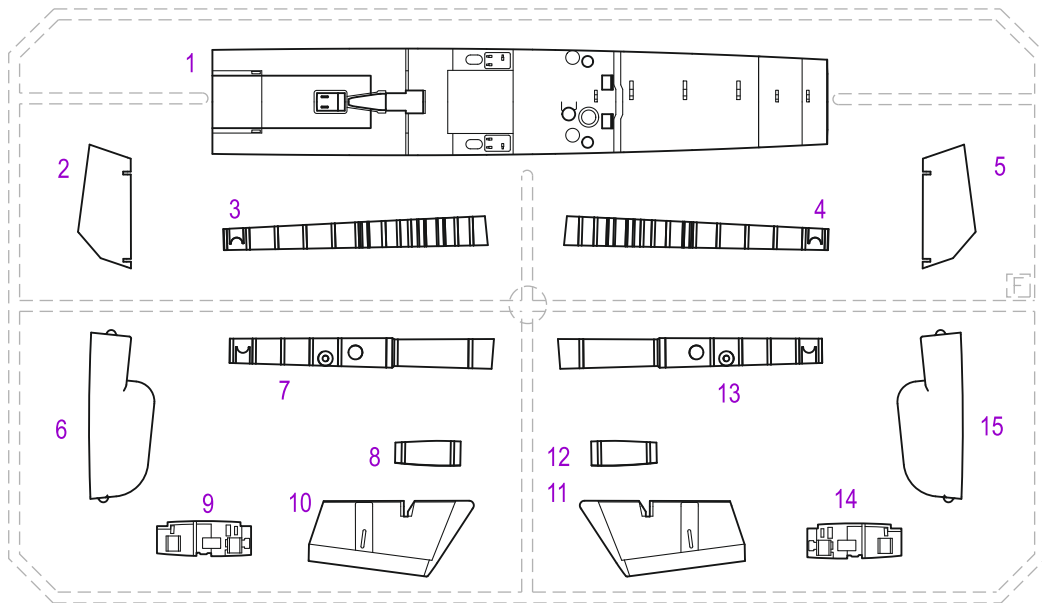
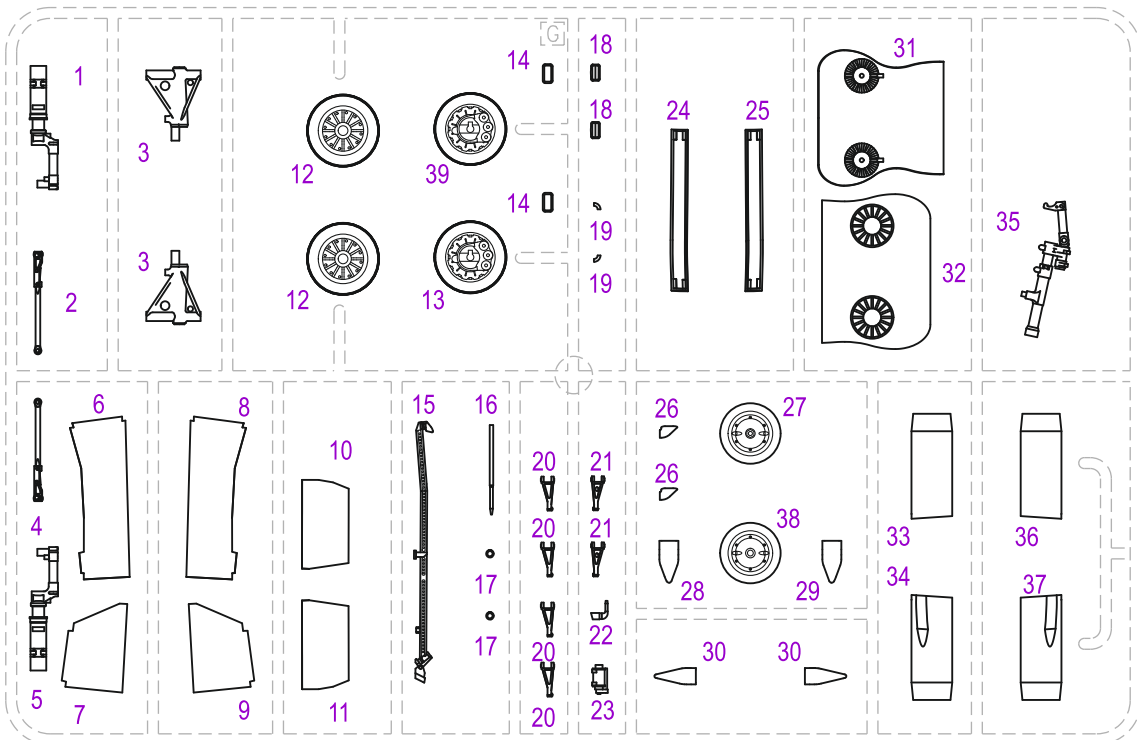
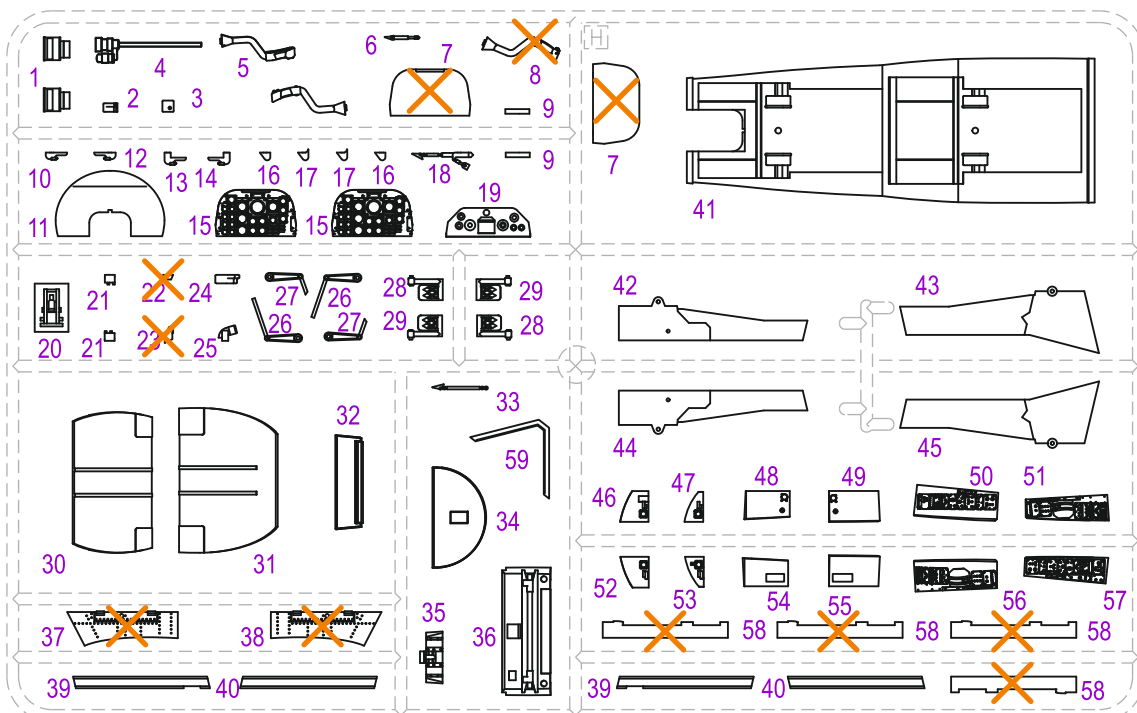
F**G****H**

Tento díl nepoužít
Do not use this part



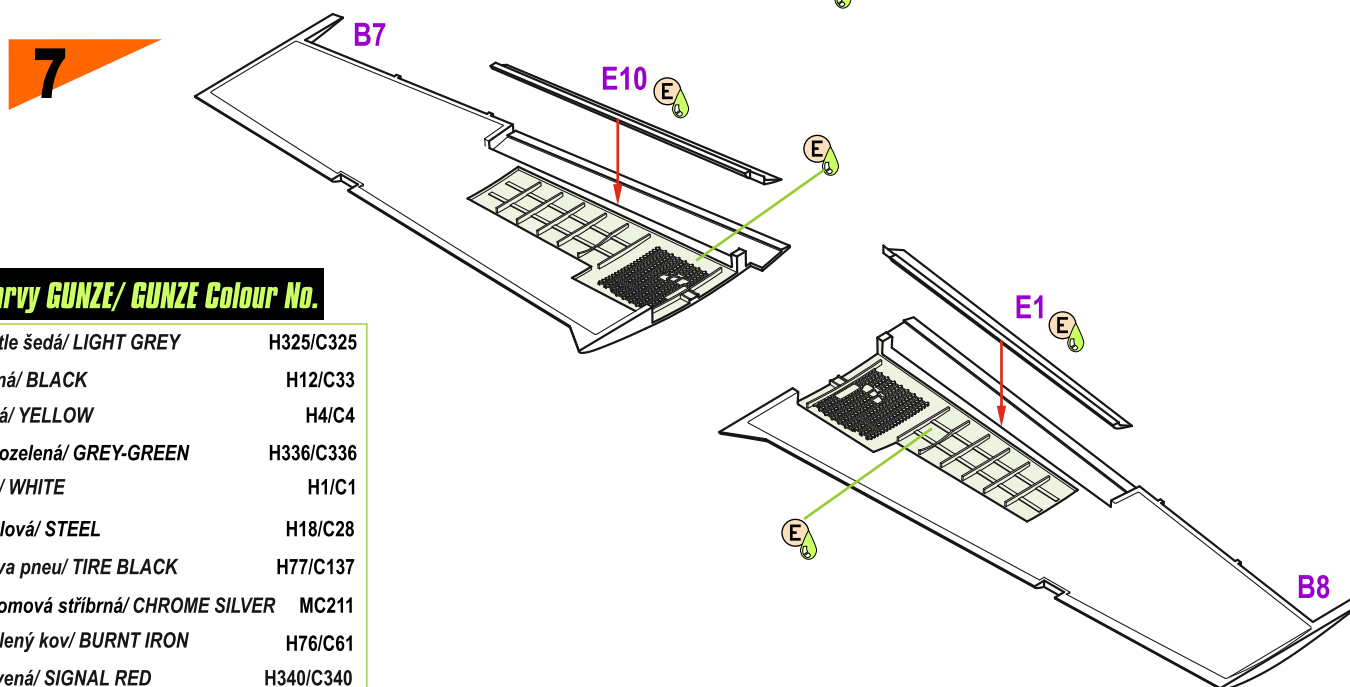
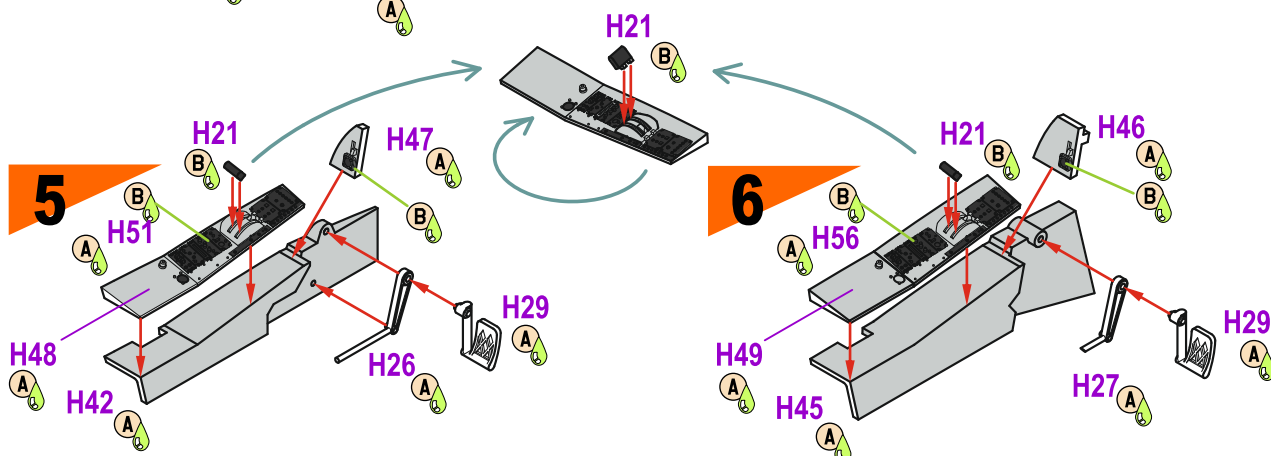
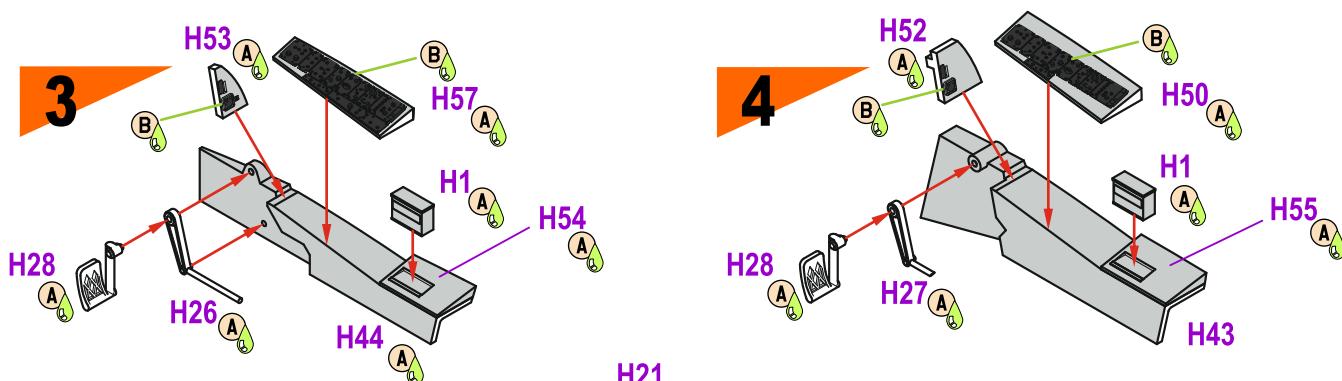
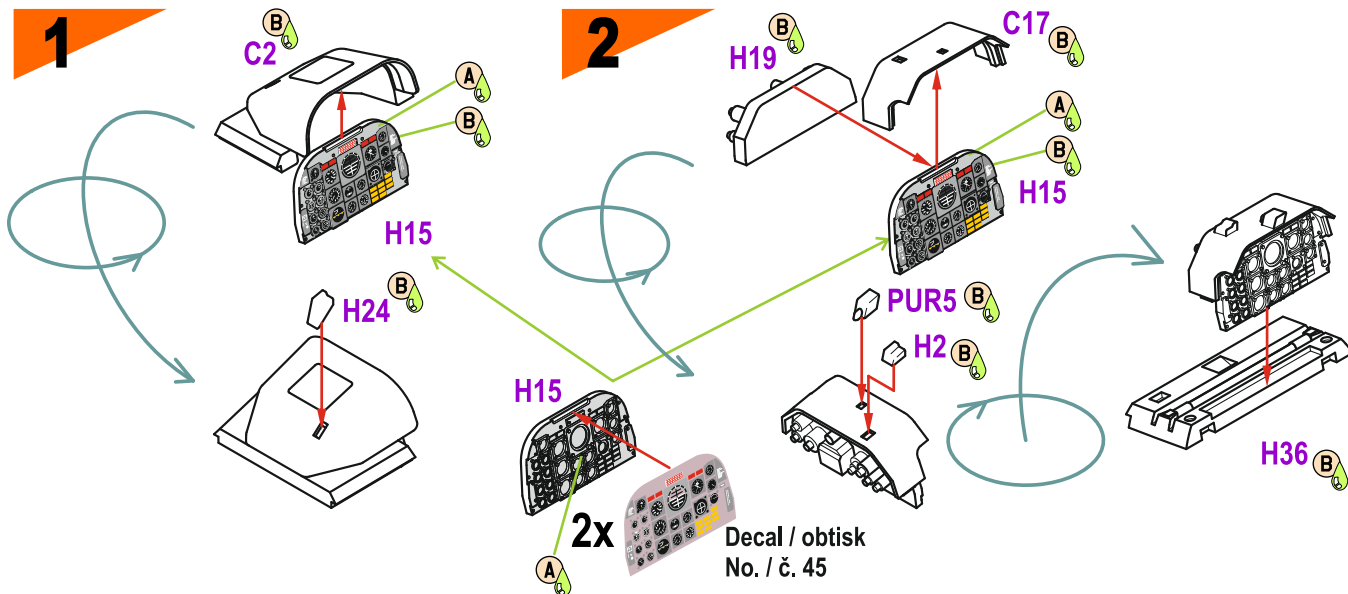

Barvy GUNZE/ GUNZE Colour No.

A	Světle šedá/ LIGHT GREY	H325/C325
B	Černá/ BLACK	H12/C33
C	Žlutá/ YELLOW	H4/C4
D	Šedozelená/ GREY-GREEN	H336/C336
E	Bílá/ WHITE	H1/C1
F	Ocelová/ STEEL	H18/C28
G	Barva pneu/ TIRE BLACK	H77/C137
H	Chromová stříbrná/ CHROME SILVER	MC211
I	Opálený kov/ BURNT IRON	H76/C61
J	Červená/ SIGNAL RED	H340/C340
K	Červená čirá/ CLEAR RED	H90/C47

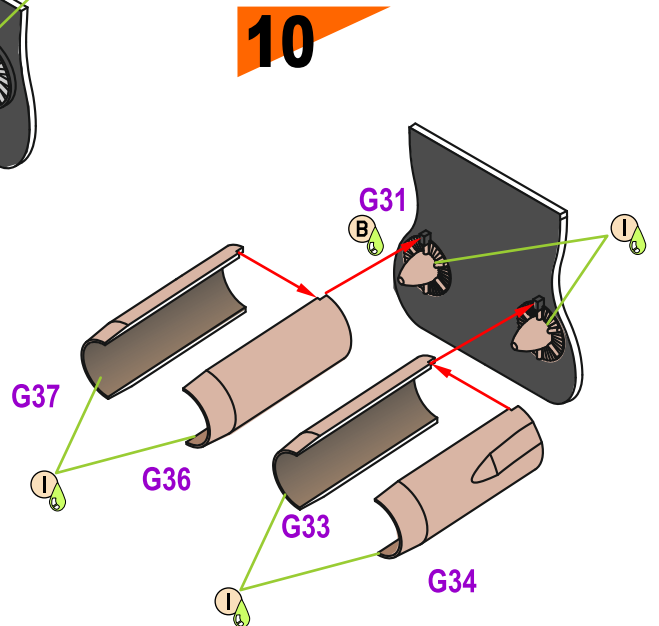
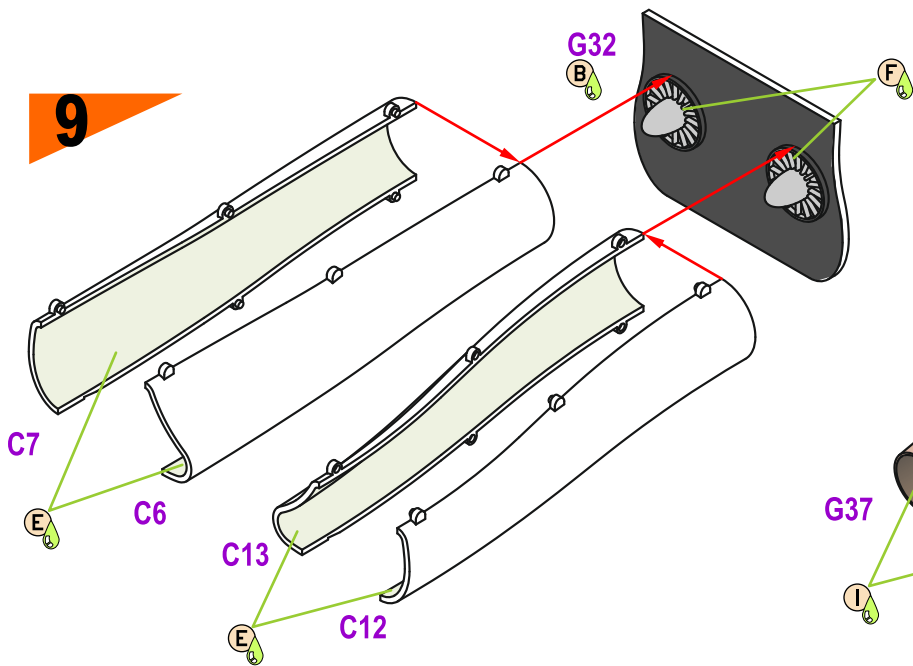
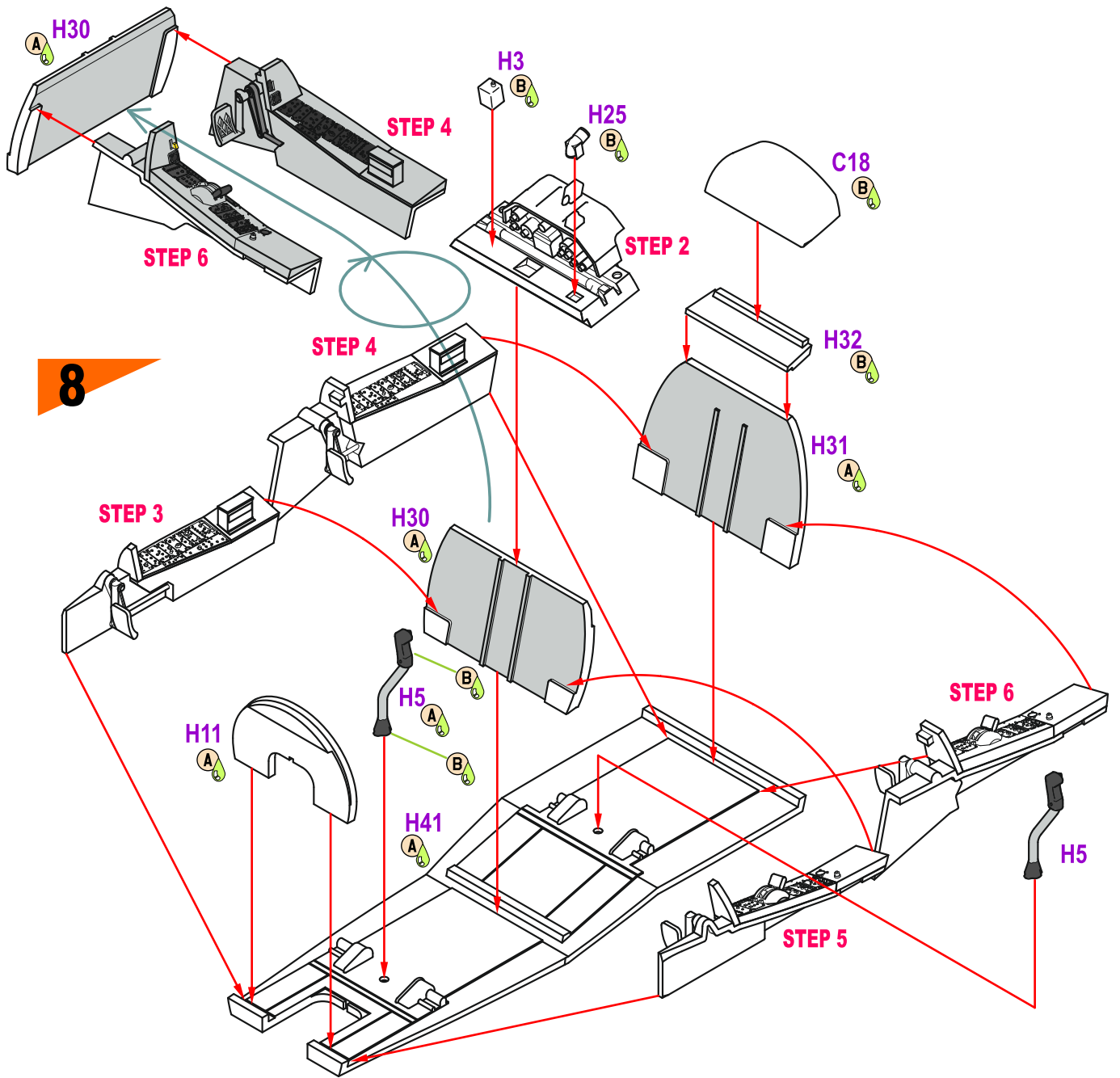

11

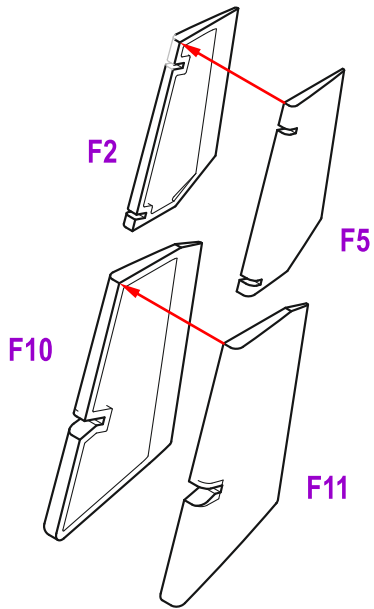

12 2x

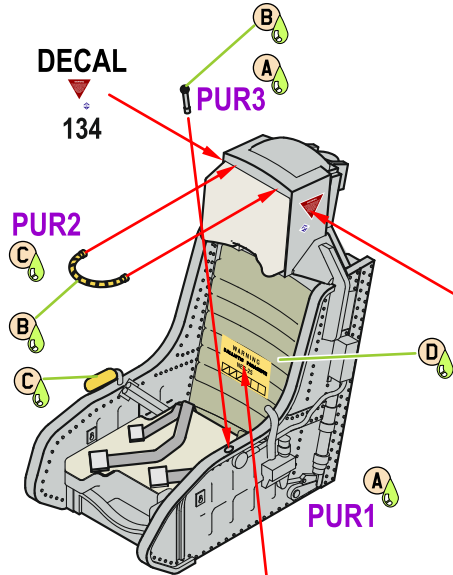

13

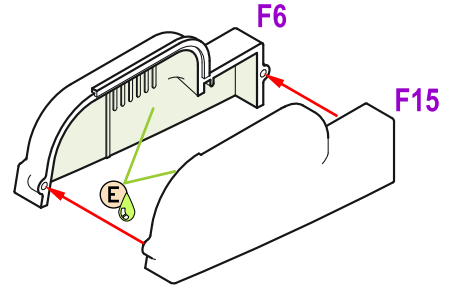

14

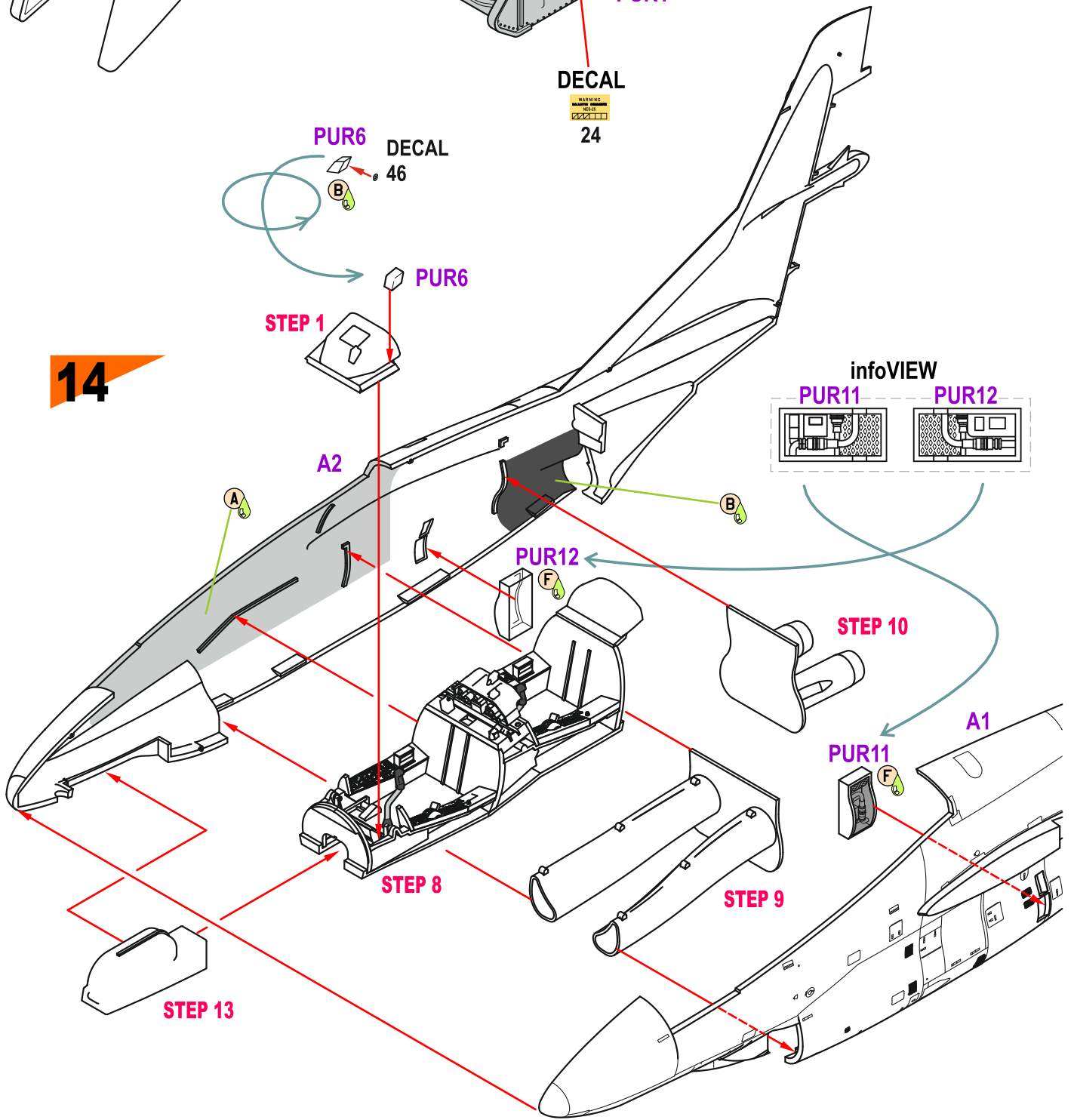

15

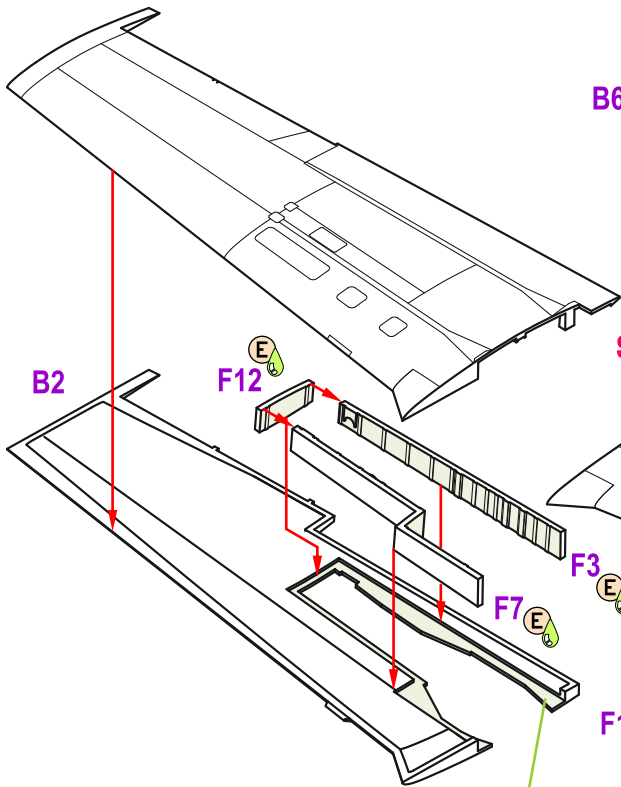

16

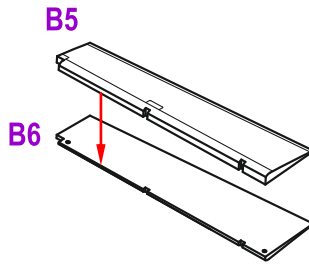

17

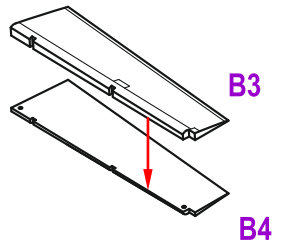

STEP 7

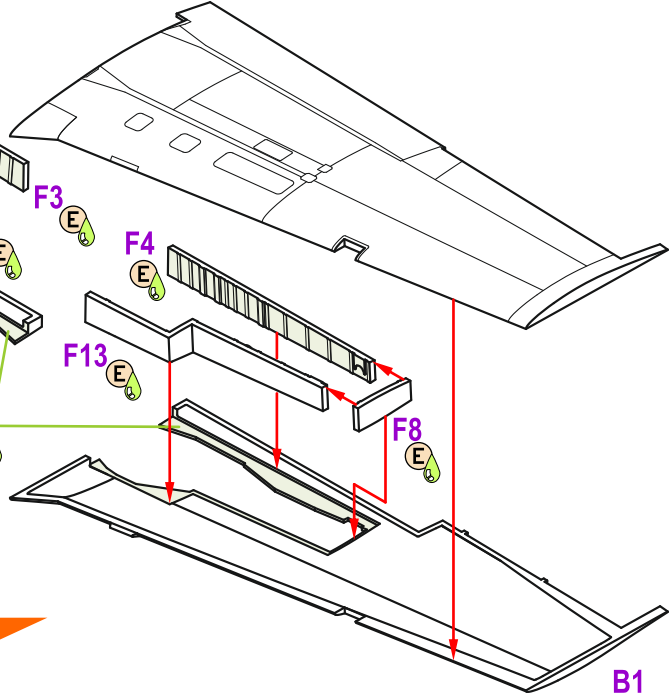

18

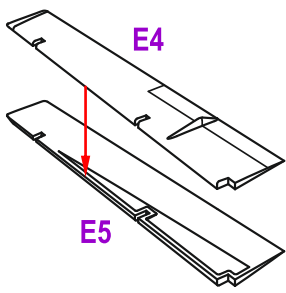

19

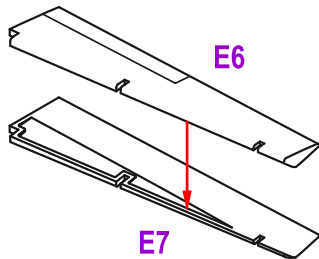

20

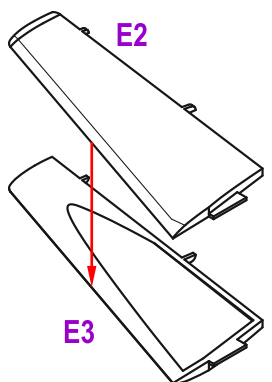

21

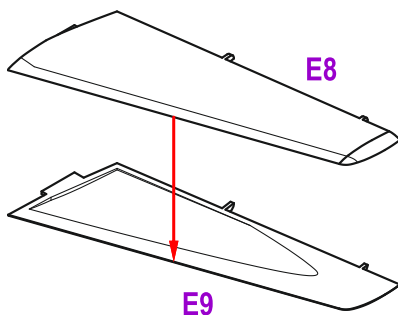

22

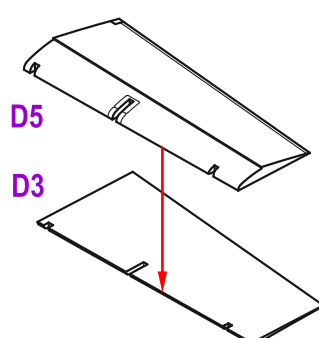

23

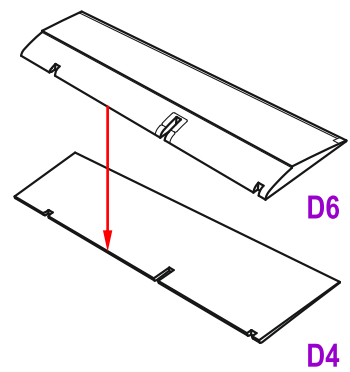

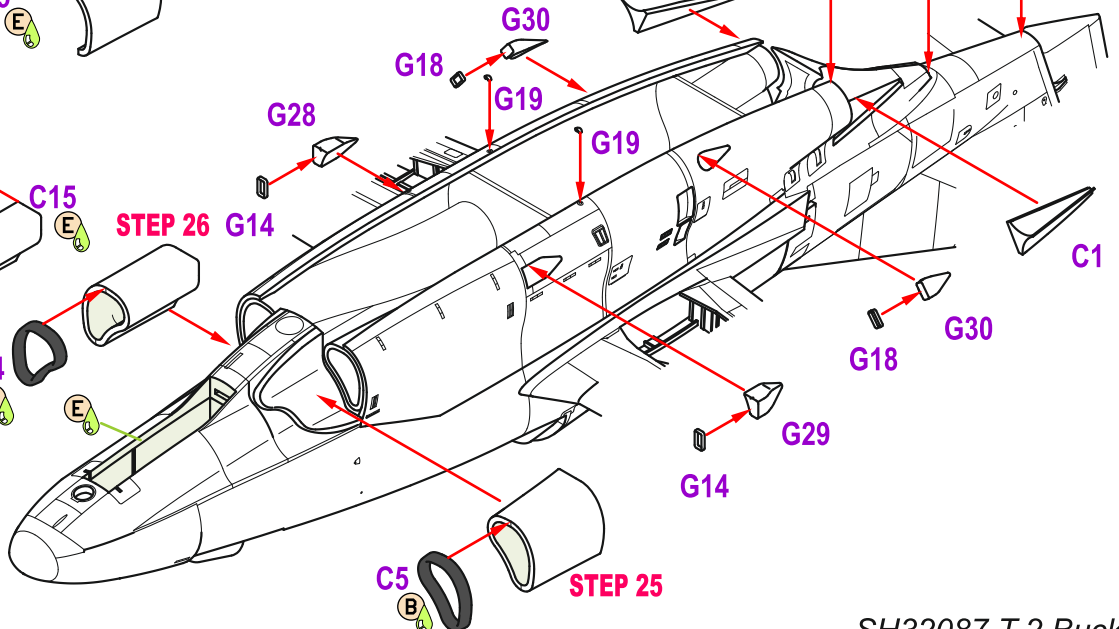
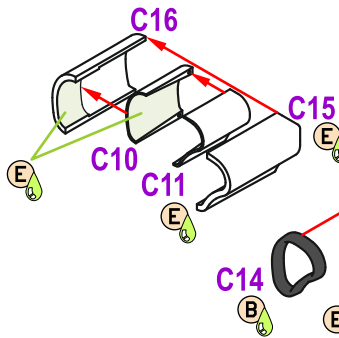
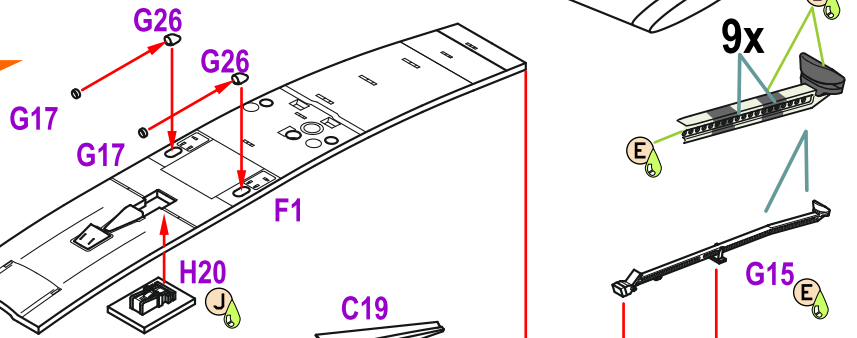
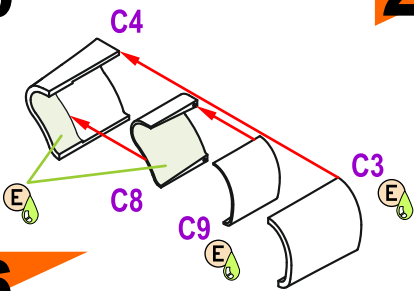
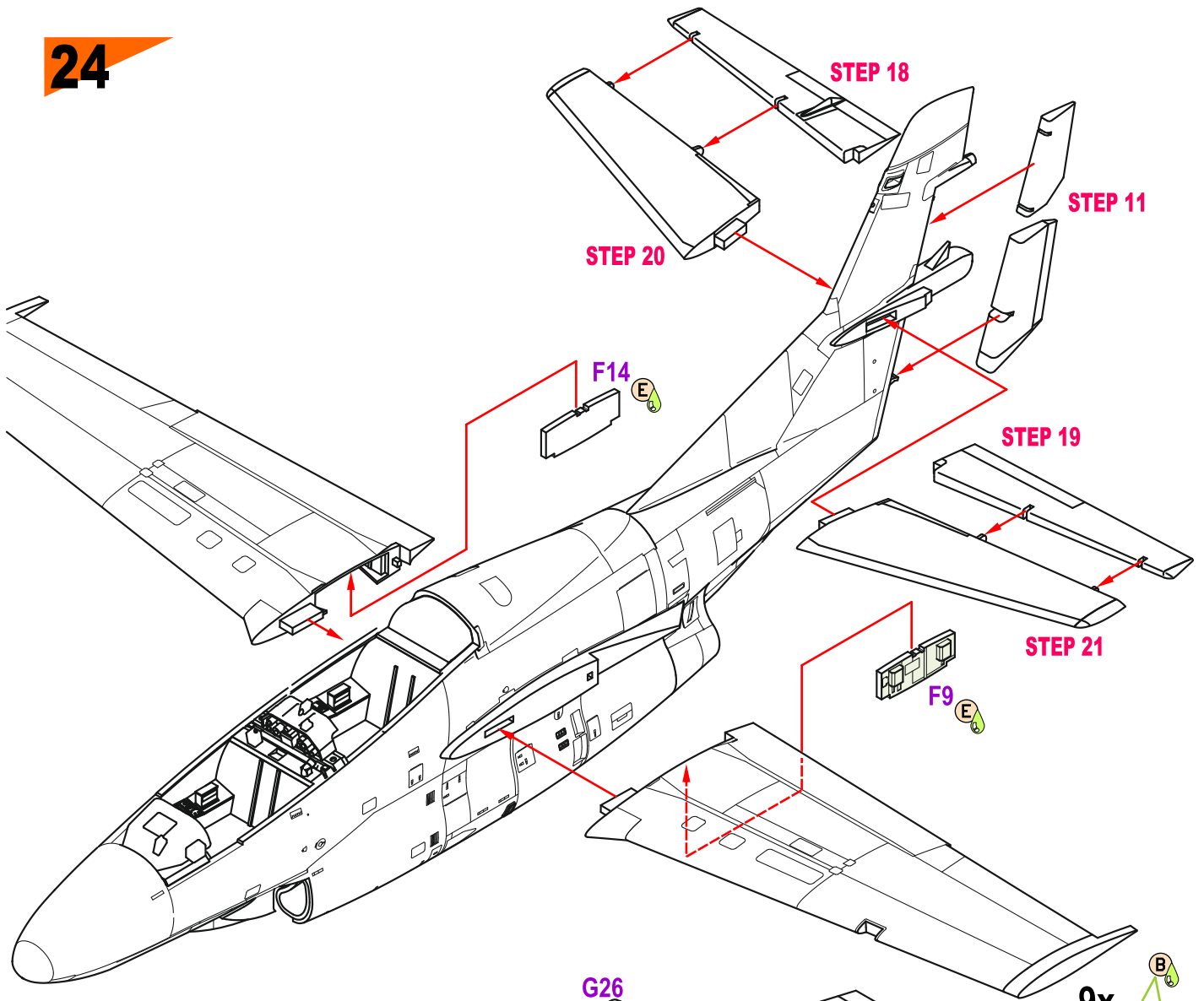

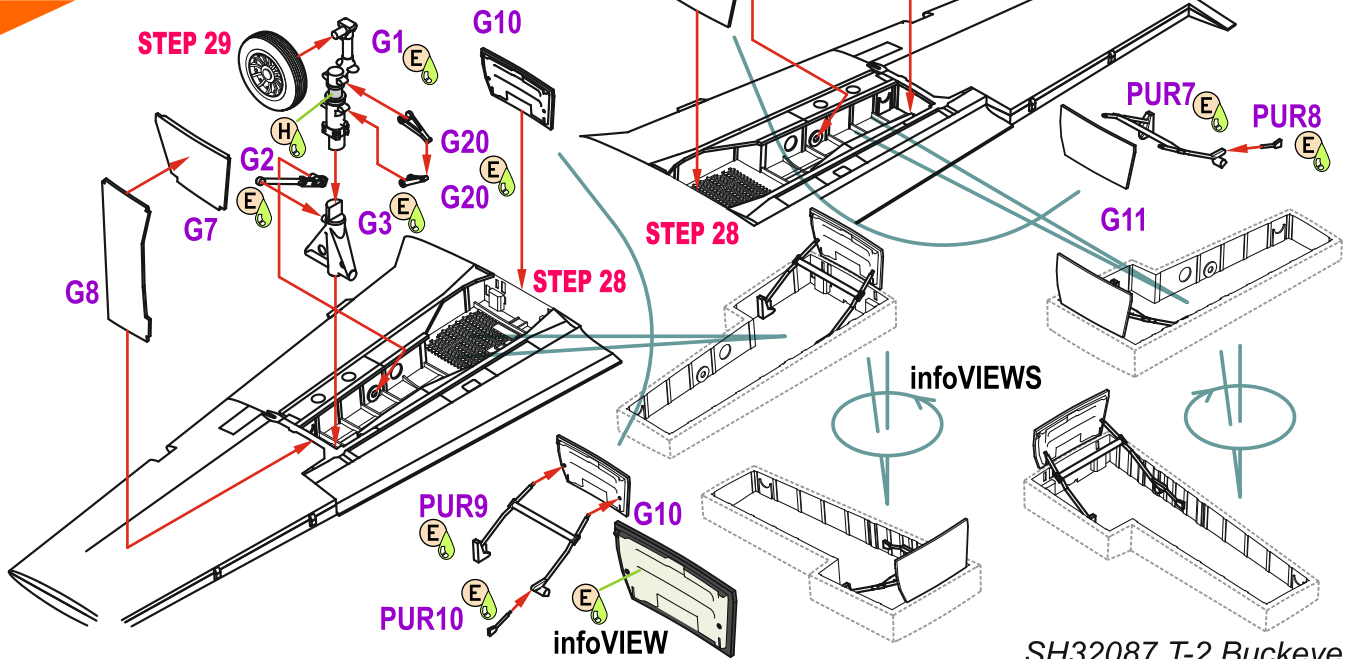
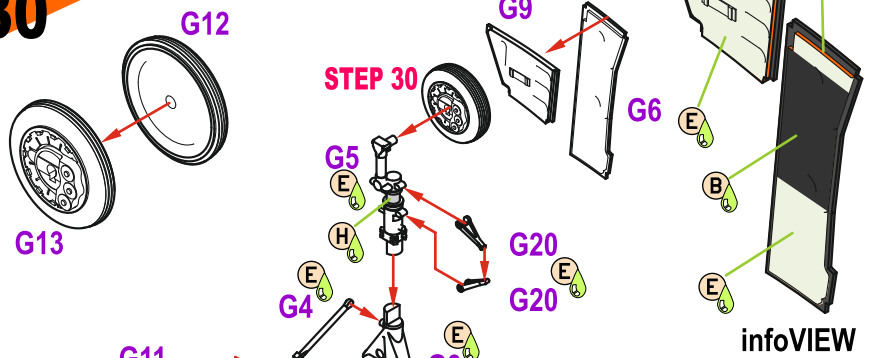
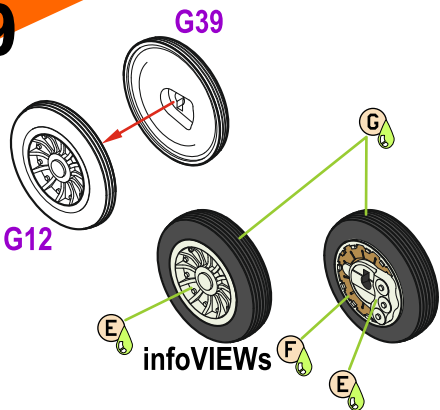
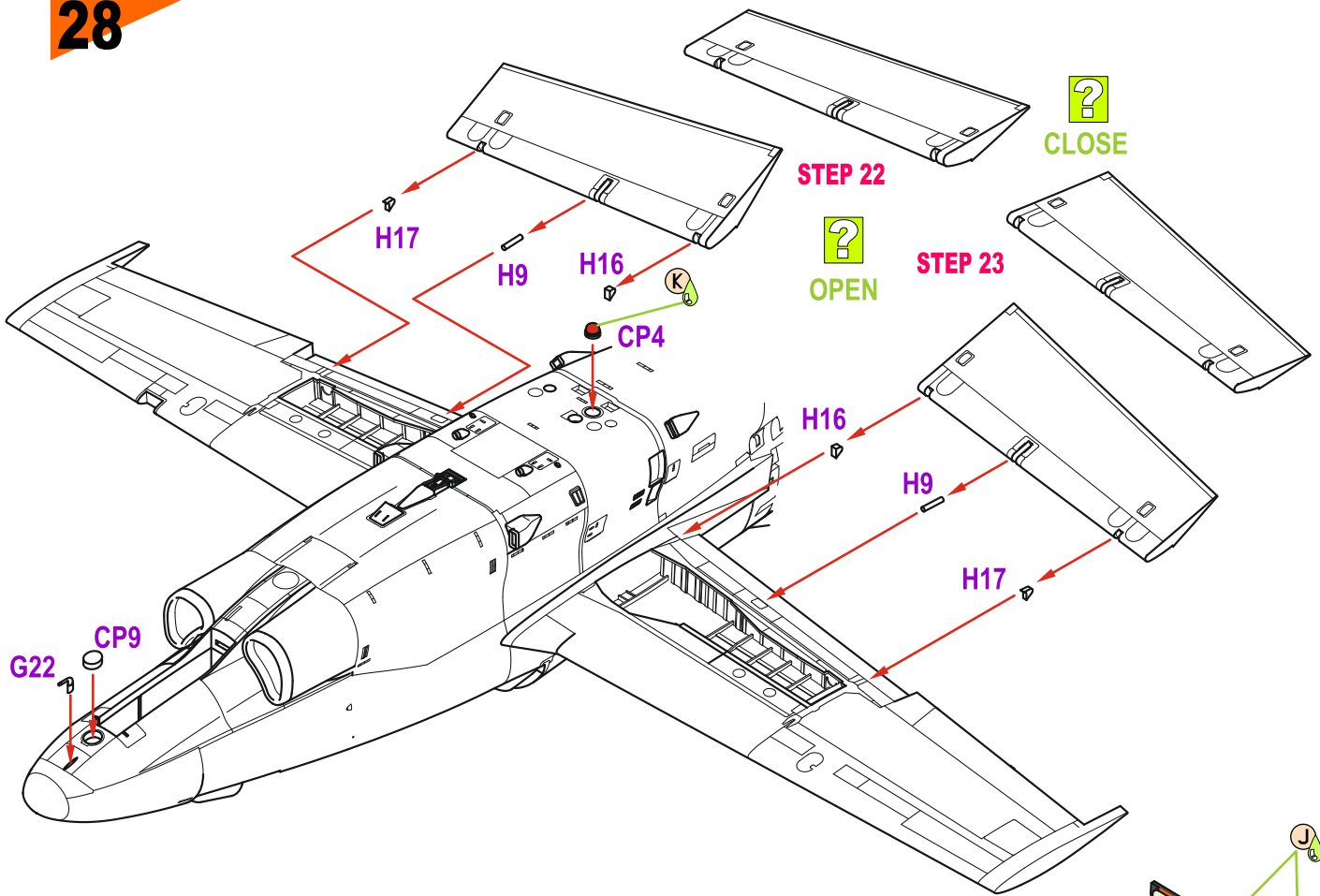

23

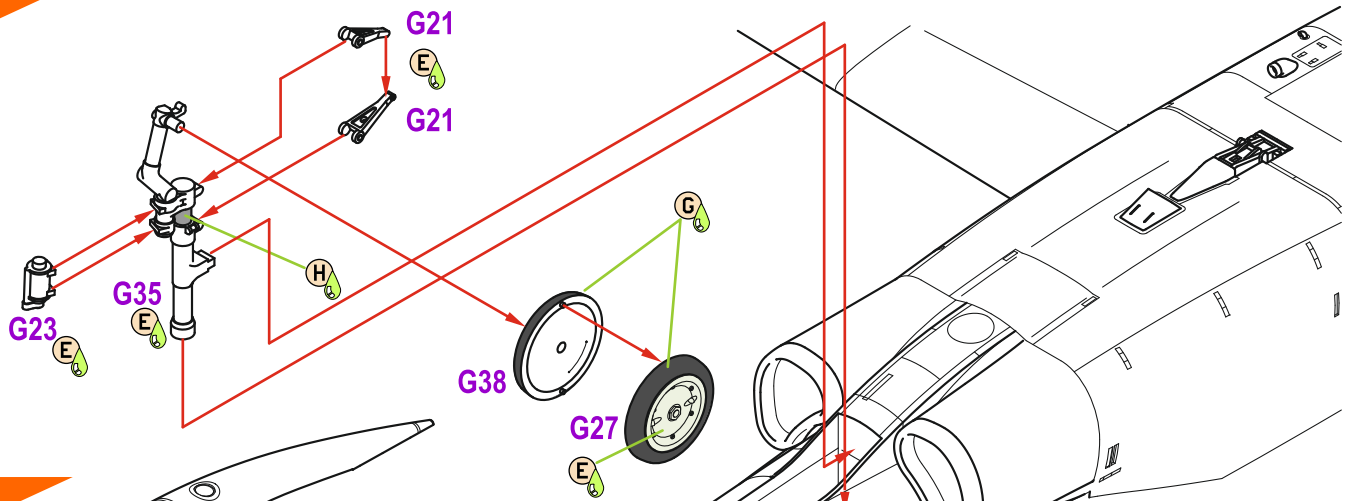

33

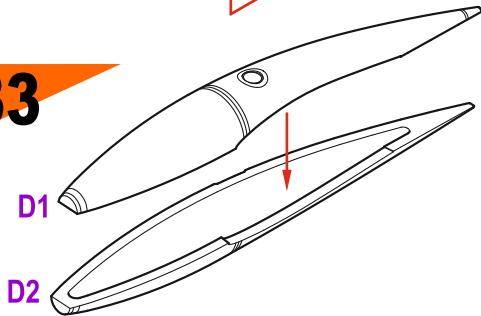

34

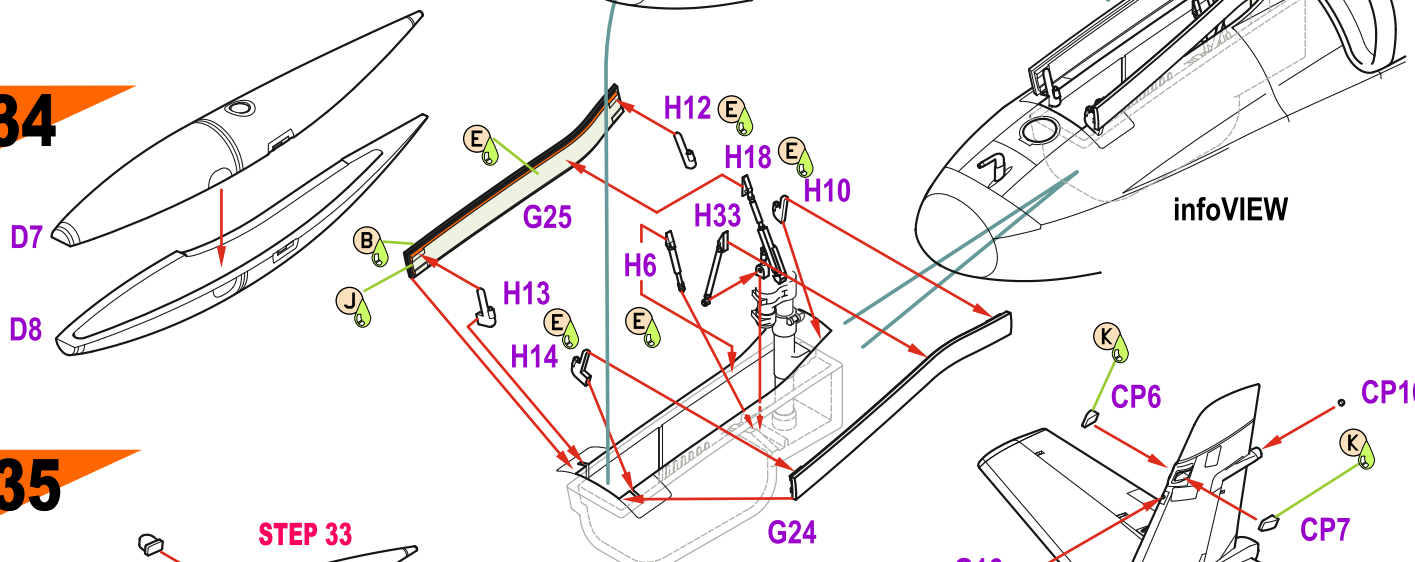

35

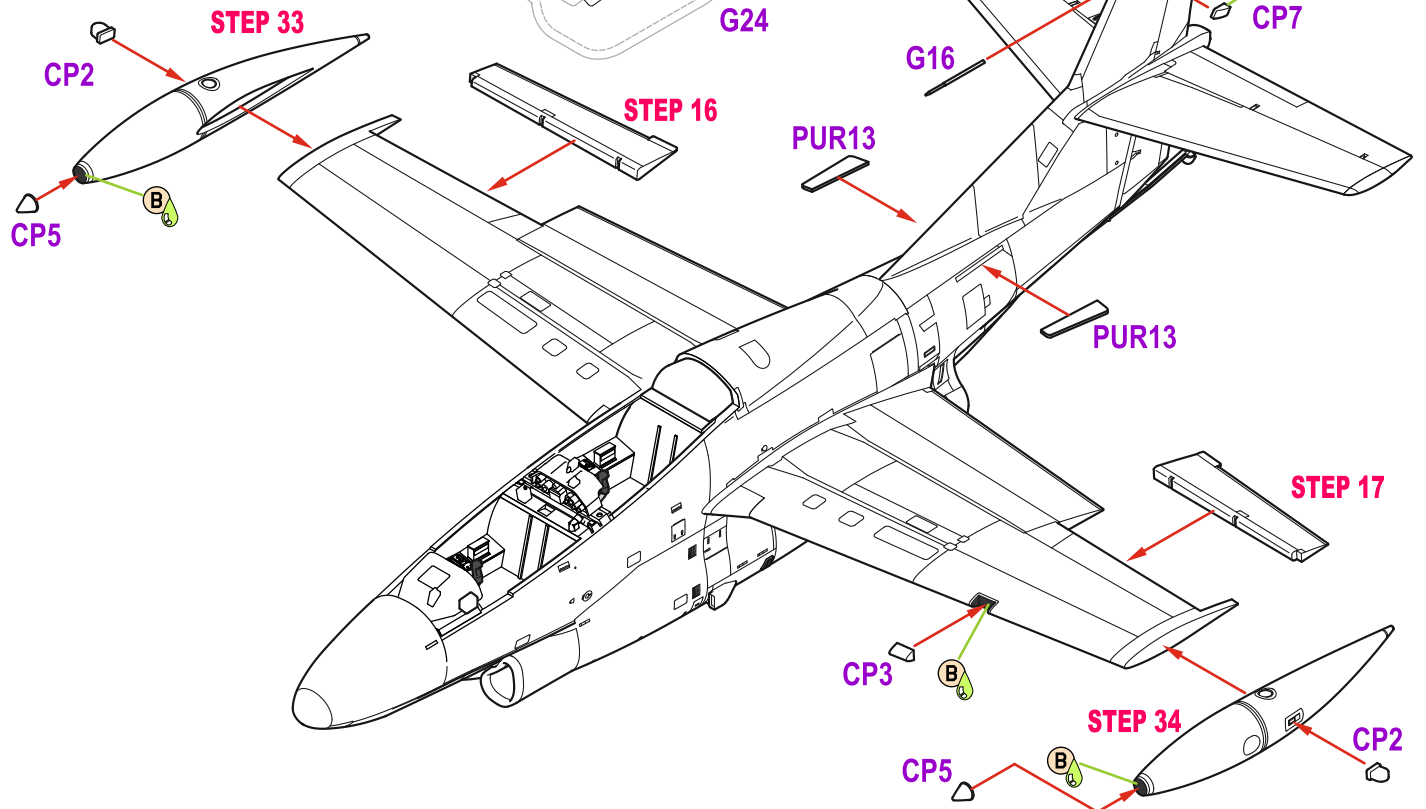

36

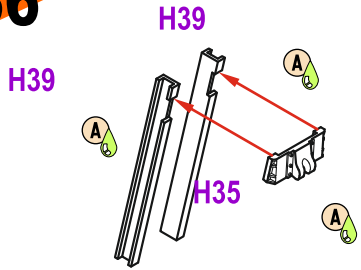

37

STEP 12

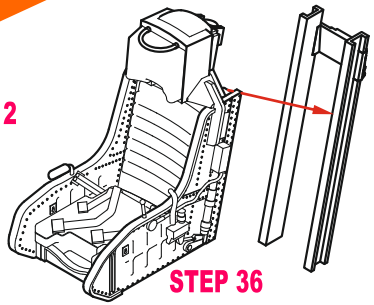

38

STEP 12

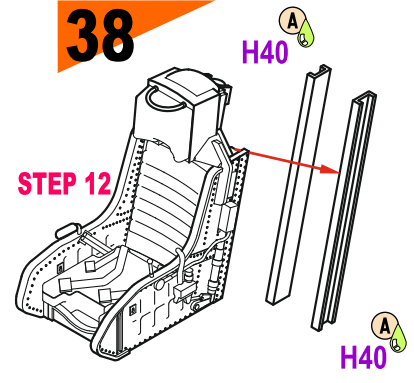

39

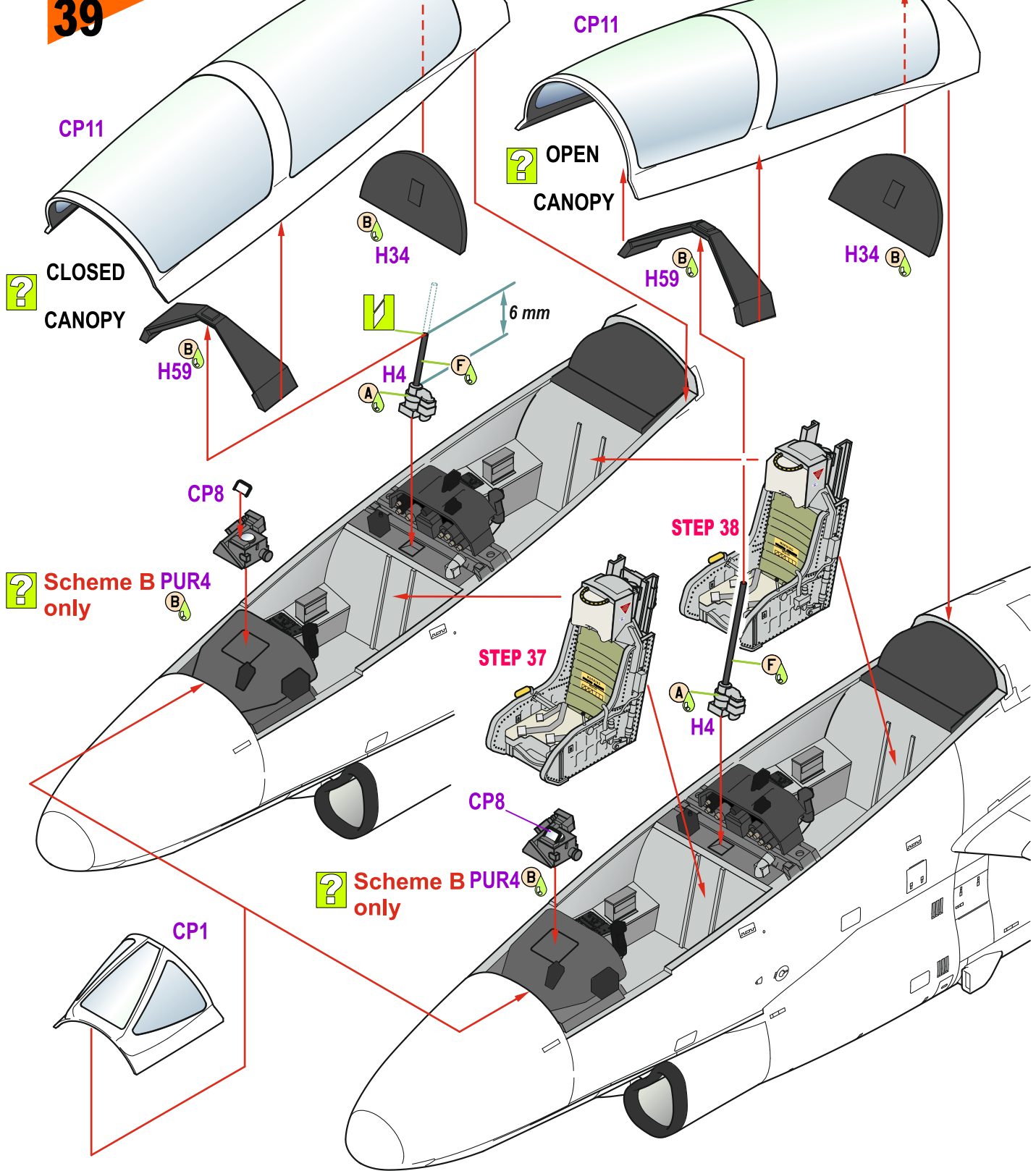



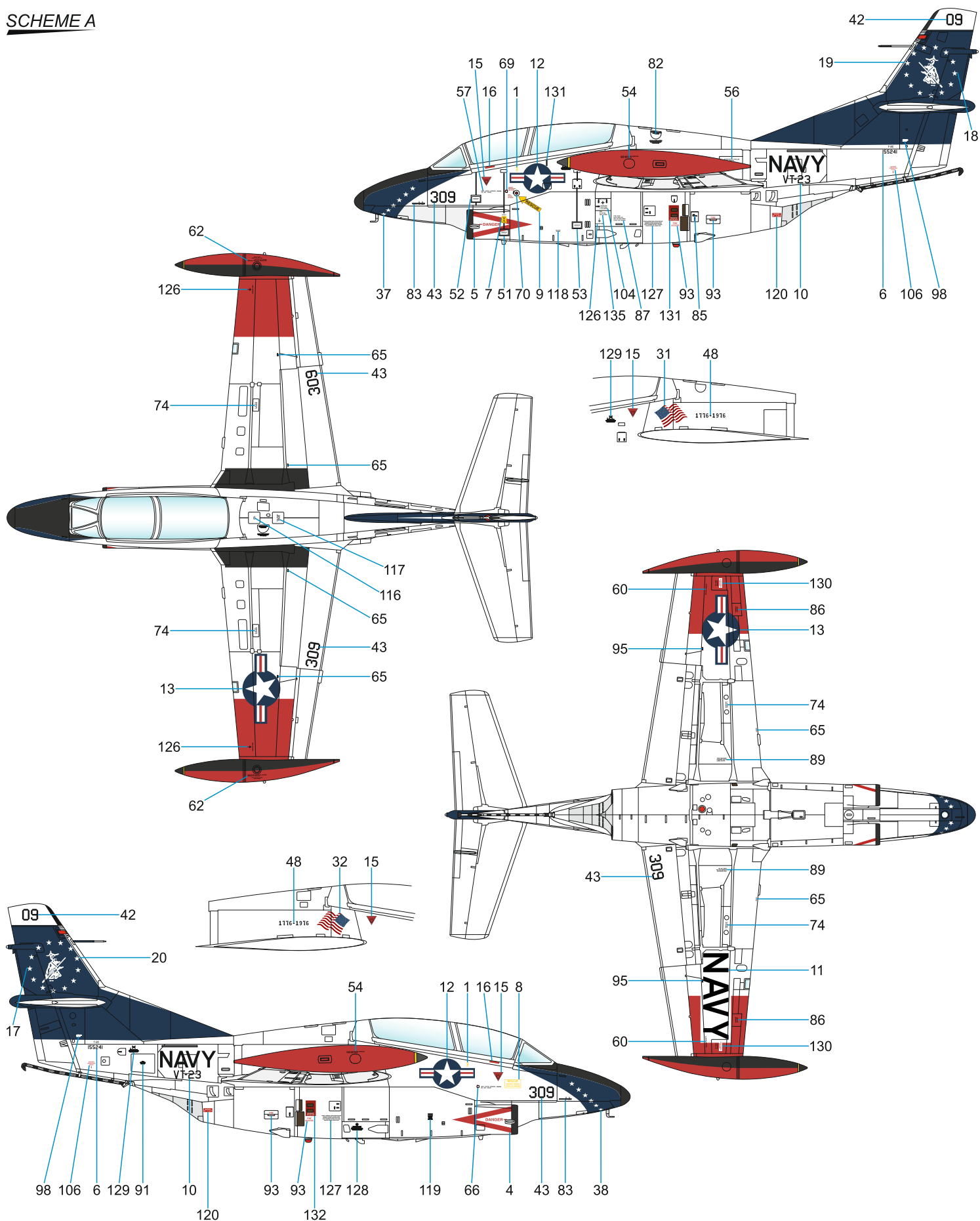

T-2C Buckeye, Bu.No. 155241, No.309, VT-23 'The Professionals', Naval Air Station Kingsville, Texas. V roce 1976, při příležitosti dvousetleté existence USA, dostaly letouny T-2C jednotky VT-23 výroční zbarvení s modrou přídí a svíslou ocasní plochou.

T-2C Buckeye, Bu.No. 155241, No.309, VT-23 'The Professionals', Naval Air Station Kingsville, Texas. In 1976 to mark the United States Bicentennial, the T-2C Buckeyes of VT-23 were painted blue on the nose section and the tailfin.

SCHEME A



- | | | | | | | | |
|--|--|---|---|---|-------------------------------------|---|---------------------------------|
|  | <i>Matná černá</i>
Flat Black
H12/ C33 |  | <i>Tmávě modrá</i>
Dark Blue
H328/ C328 |  | <i>Červená</i>
Red
H327/ C327 |  | <i>Bílá</i>
White
H21/ C1 |
|--|--|---|---|---|-------------------------------------|---|---------------------------------|

T-2E Buckeye, Bu No. 160084, No.84, 363 MEA 'Danaos' (MEA - Mira Ekpedefsis Aeros/ Ietecká cvičná perut'), 120 PEA (PEA - Pteriga Ekpedefseos Aeros/ Ietecké cvičné křídlo), základna Kalamata, řecké vojenské letectvo. Při příležitosti čtyřicetileté existence 363 MEA dostal tento letoun v roce 2012 výroční zbarvení.

T-2E Buckeye, Bu No. 160084, No.84, 363 MEA 'Danaos' (MEA - Mira Ekpedefsis Aeros/ Air Training Squadron), 120 PEA (PEA - Pteriga Ekpedefseos Aeros/ Air Training Wing), Kalamata, Hellenic Air Force. For the 40th anniversary of the 363 MEA in 2021, this airframe received special colour scheme.

SCHEME B

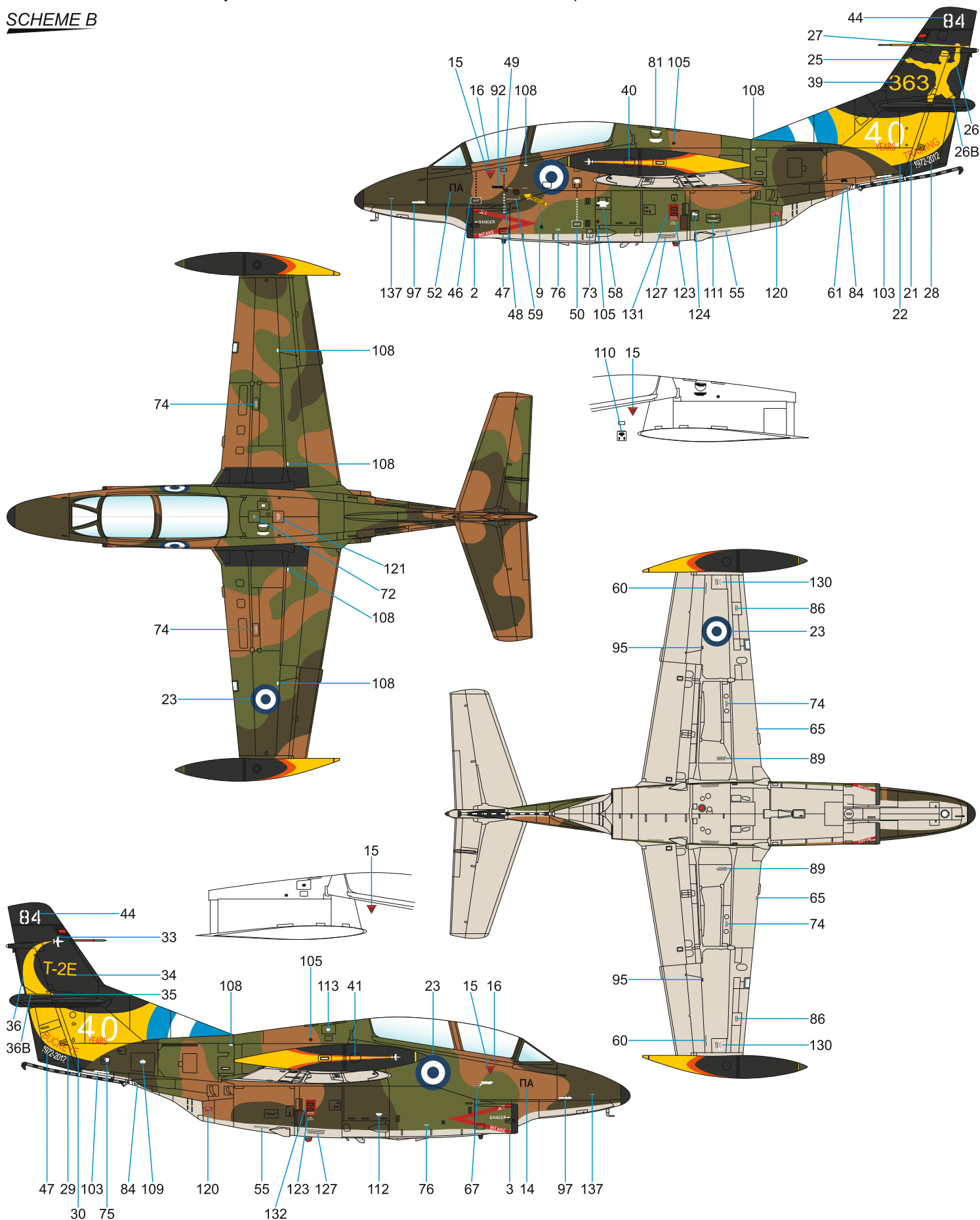

-  **Matná černá**
Flat Black
H12/ C33
-  **Tmávě zelená**
Dark Green
H309/ C309
-  **Středně zelená**
Medium Green
H303/ C303
-  **Tříslivá**
Tan
H310/ C310
-  **Světle šedá**
Light Grey
H311/ C311

Pro zjednodušení stavby modelu T-2 Buckeye nabízíme samostatně prodávané předřezané vnější i vnitřní masky M32008

If you want to make the build of your T-2 Buckeye easier, we offer the pre-cut Inside/Outside mask M32008

Special MASK T-2 Buckeye 

M32008 for Special Hobby kit 1/32

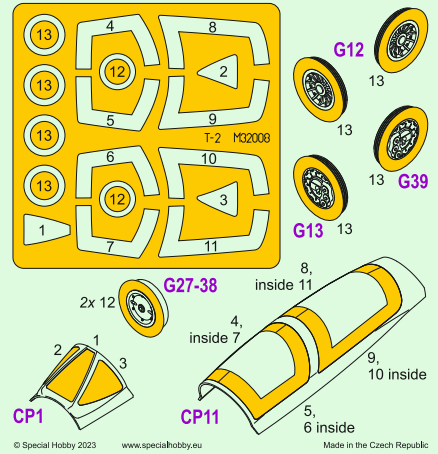

ATTRACTIVE 1/32 SCALE SET FOR COBRA!

5144 M35 ARMAMENT SUBSYSTEM Upgrade Set for AH-1G Cobra

CMK sets for ICM and Revell kits



1/32 SH32082

PUR parts



3D-printed parts



Masks



Photo-etched parts



AH-1G COBRA 'Early Tails over Nam' Hi-Tech Kit



1/32 SH32086

AH-1G Cobra 'Marines/US Navy' Hi-Tech Kit

Hi-Tech Kit



 facebook.com/specialhobby

WWW.SPECIALHOBBY.EU

ATTRACTIVE 1/32 SCALE MODELS

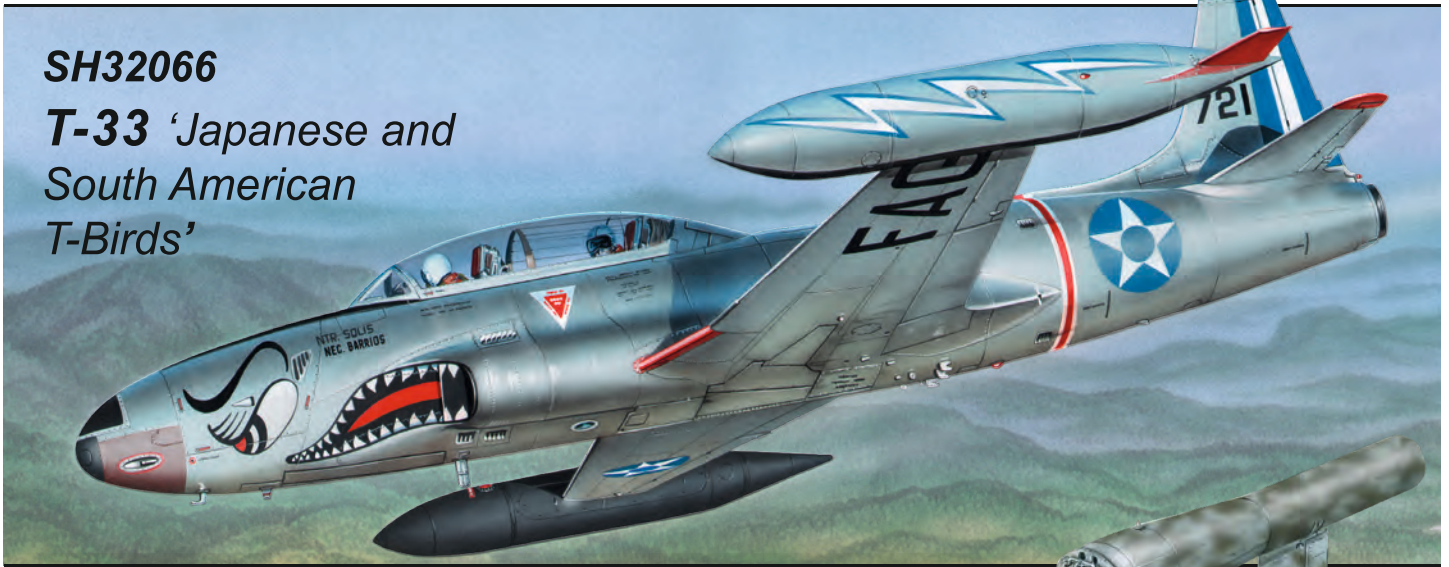

SH32066

T-33 'Japanese and South American T-Birds'

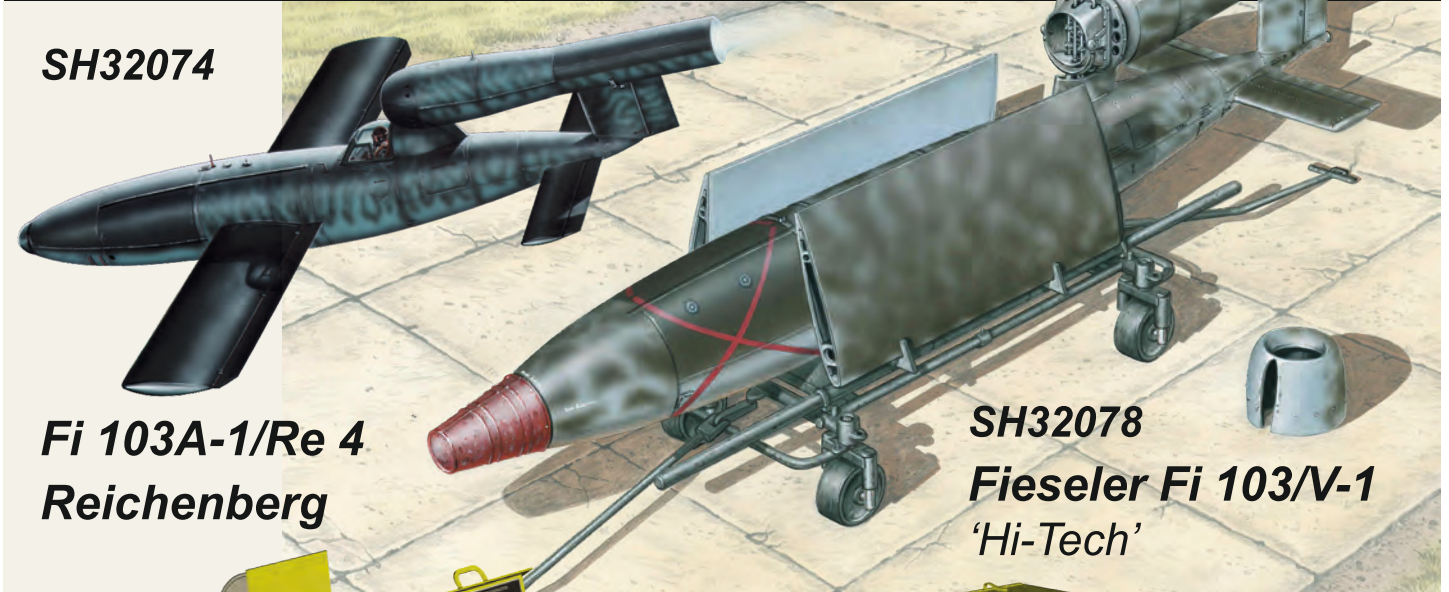

SH32074

Fi 103A-1/Re 4 Reichenberg

SH32078

Fieseler Fi 103/V-1 'Hi-Tech'



5114

MA-1A USAF Start Cart



5130

MD-3 Ground Power Unit

Excellent
CMK
RESIN
SETS



Star Dust
weathering pigments

