

P35016
1/35

M18 57 mm
Recoilless Rifle



PE - Photo-etched parts



3D-Printed Parts

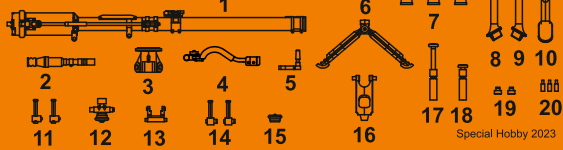

www.facebook.com/specialhobby/

Ohnuté 3D tisky narovnejte ponořením do horké vody, srovnejte je a zchladte studenou vodou. K lepení použít kyanoakrylátové lepidlo! Kontaktní plochy doporučujeme před lepením odmastit. Různé drátky a tyčinky nejsou přiloženy.

Bent 3D printed parts: put them into hot water, straighten them and cool them in cold water. For best result use cyanoacrylate glue! Ungreasing contact areas is recommended before gluing. Wires and rods not included.

Special Hobby also offers 1/35 3D printed sets P35011M2 Flamethrower and P35003 Small Arms for the Volkssturm Set III

P35011



P35003



more at www.specialhobby.eu

Special Hobby, Mezilesí 718, CZ - Praha 9, 193 00, e-mail: office@specialhobby.eu

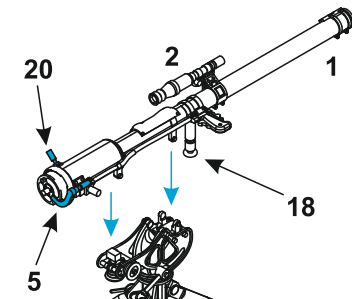
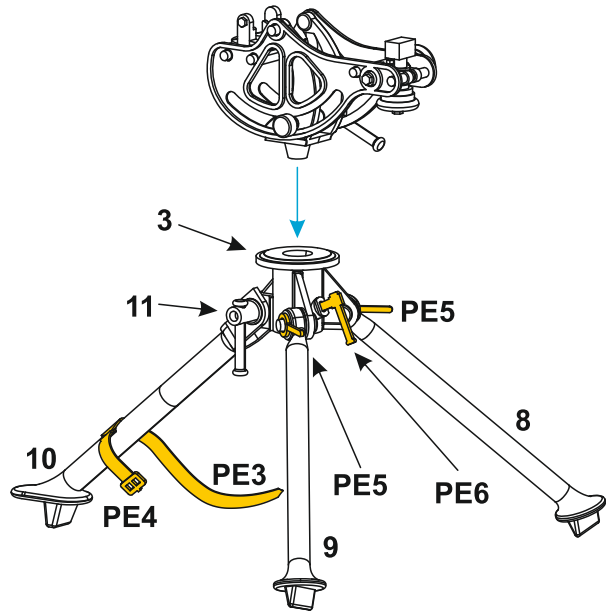
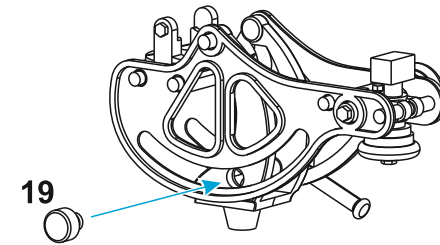
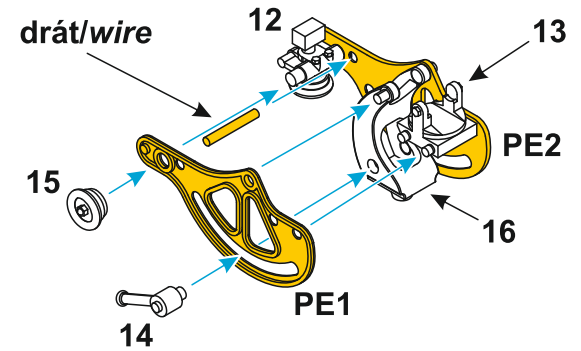

varianta 1
option 1

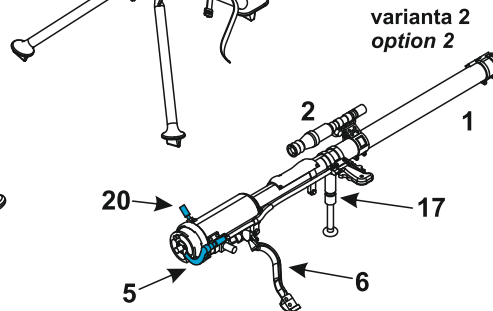

varianta 2
option 2

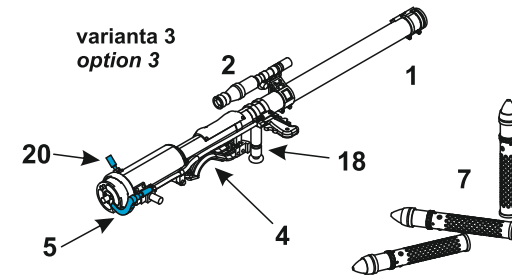

varianta 3
option 3

Special Hobby also offers 1/35 3D printed set P35014 M1 Bazooka

