

Unimog 406 DoKa Letištní tahač - Bundeswehr - opravárenská jednotka, Luftwaffe 1968
 Unimog 406 DoKa Airport Tug - Bundeswehr - repair unit, Luftwaffe 1968

Zelená NATO RAL 6014
 NATO Olive Green RAL 6014

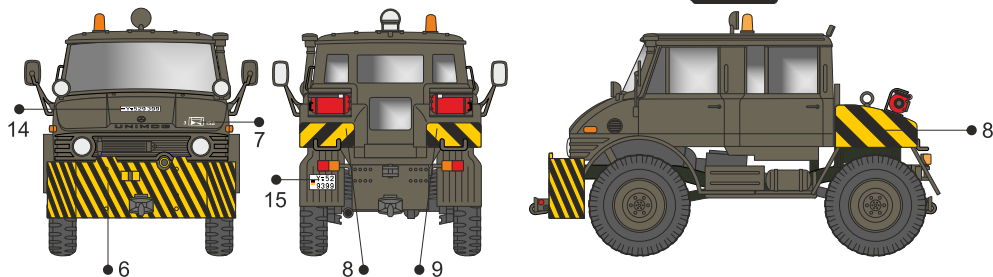

Unimog 406 DoKa Letištní tahač - Bundeswehr - 1968
 Unimog 406 DoKa Airport Tug - Bundeswehr - 1968

Zelená NATO RAL 6014
 NATO Olive Green RAL 6014

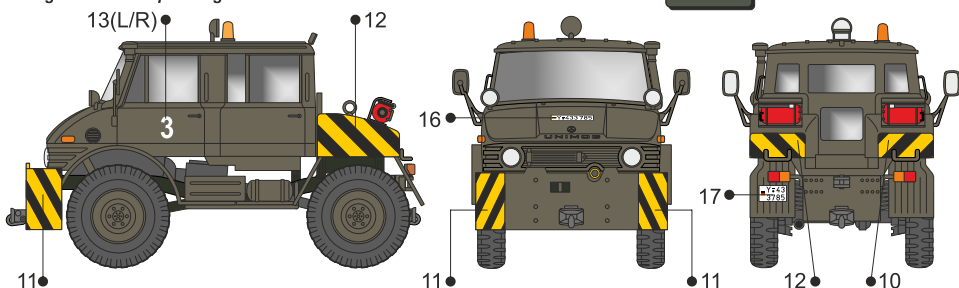

Unimog 406 DoKa Letištní tahač - NSR 1965
 Unimog 406 DoKa Airport Tug - BRD 1965

Žlutá RAL 1034
 Yellow RAL 1034

Zelená RAL 6029
 Green RAL 6029

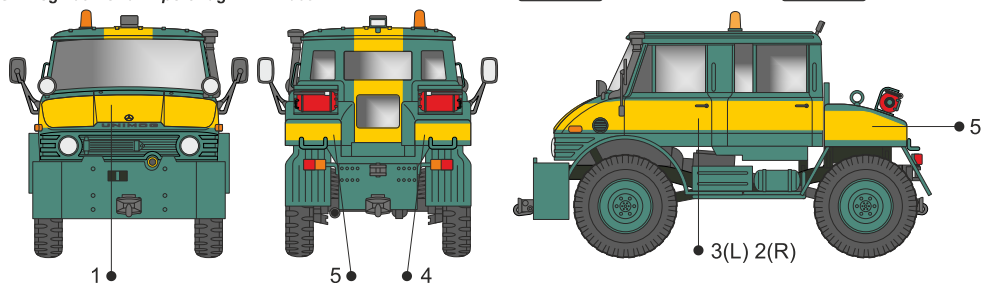

BARVY / COLORS

- | | | |
|----------|-------------------------------|-----|
| A | Černá / Black | 33 |
| B | Bílá / White | 34 |
| C | Šedá / Grey | 64 |
| D | Barva pneumatik / Color tires | 85 |
| E | Plátno / Hemp | 168 |
| F | Signální červená / Signal Red | 174 |
| G | Oranžová / Orange | 209 |

HUMBROL



MV 110

1/72

Unimog U406 DoKa Military Airport Tug + AERO Rx Towbar

Visit an official website and e-shop at www.cmkkits.com

PUR (polyuretan parts)

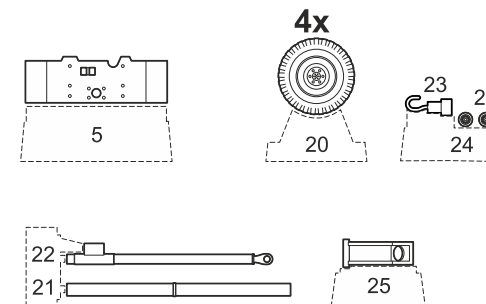
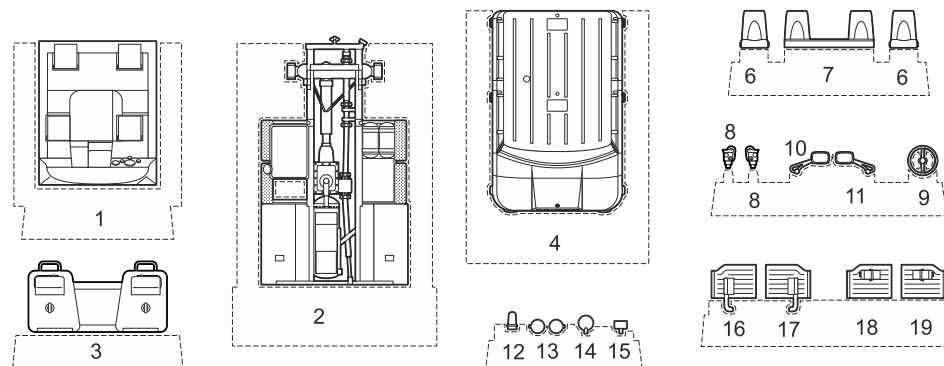

Obtisky/Decals

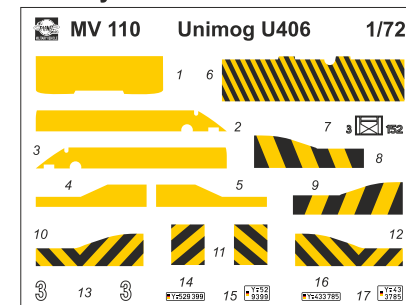

Fólie / Folie

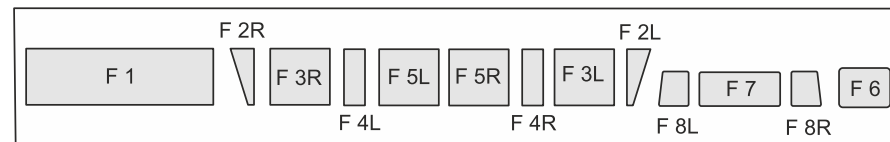

Díly ohnuté popř. pokroucené vlivem teplotních změn a stárnutí materiálu, mohou být narovnány do požadovaného tvaru pomocí proudu teplé vody nebo vzduchu (fén na vlasy). Různé drátky a tyčinky nejsou přiloženy. Kontaktní plochy doporučujeme před lepením odmastit.

Parts slightly distorted and bended owing to temperature changes or due to material ageing can be straightened to requested shape by hot water or hot air jet. (hair dryer) This process can be repeated till result is entirely satisfactory. Wires and holes not included. Contact areas ungrease is recommended before gluing

Special Hobby, Mezilesí 718, Praha 9, 193 00 - CZ, e-mail: office@specialhobby.eu

1 Zasklení kabiny a montáž sedaček / Cabin glazing and seats assembly

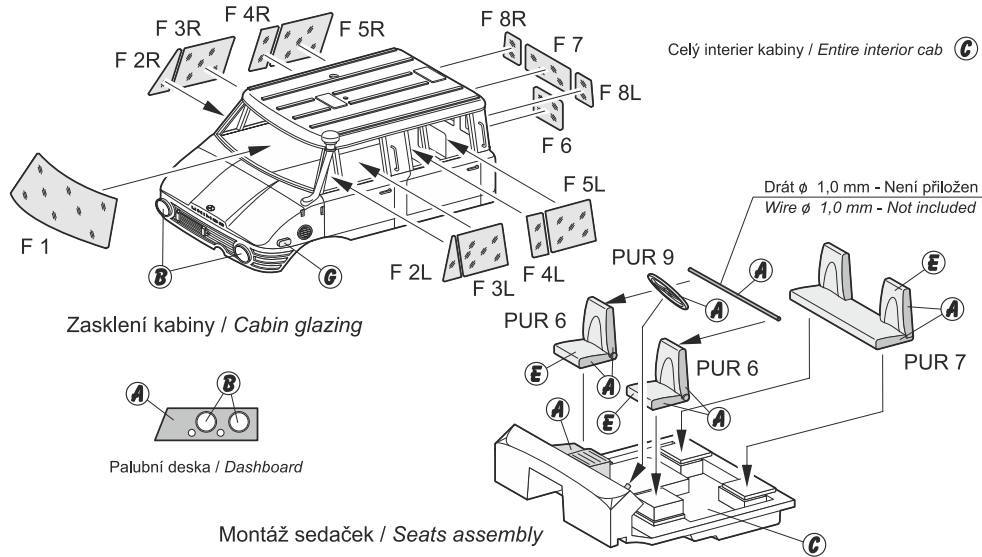

3 Sestavení a montáž kol / Wheels assembly and attachment

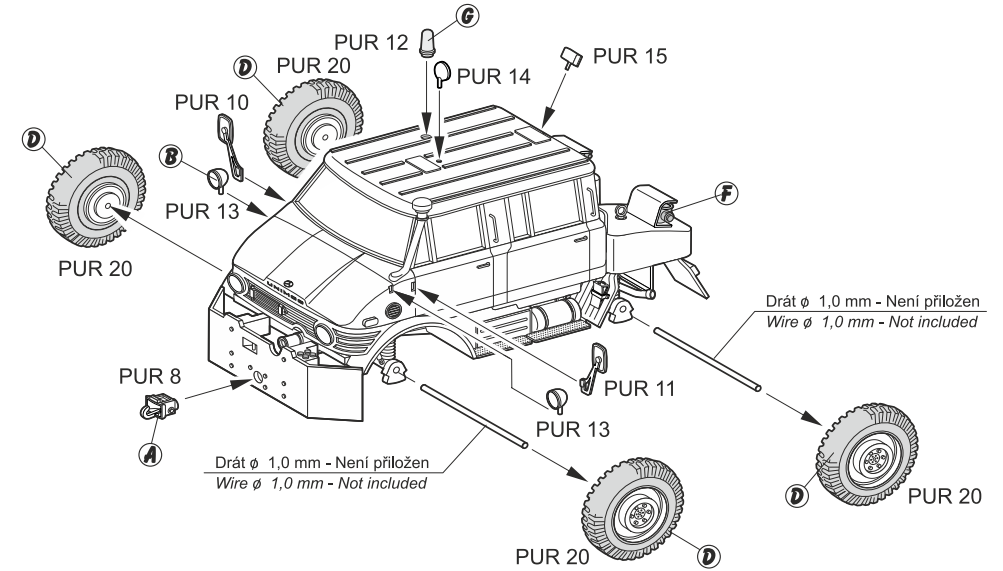

2 Celkové sestavení vozu / Final vehicle assembly

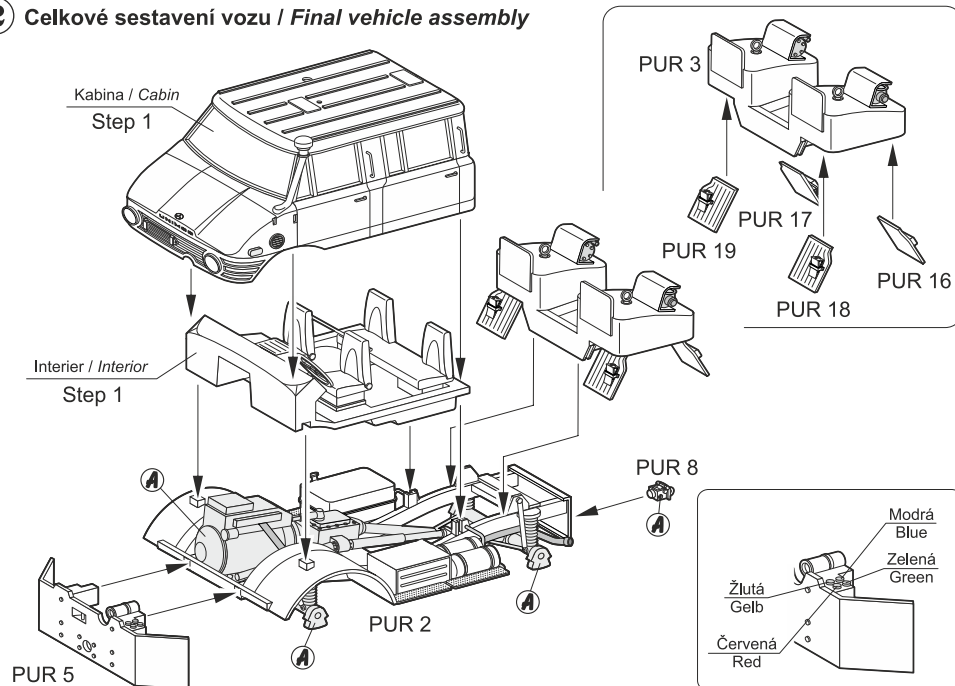

4 Sestavení vlečné tyče / Tow bar assembly

Vlečná tyč pro civilní letiště - modrá RAL5005 nebo bílá RAL9003 / Tow bar for civil airports - Blue RAL5005 or White RAL9003
Vlečná tyč pro vojenská letiště - bílá RAL9003 nebo žlutá RAL1034 / Tow bar for military airports - White RAL9003 or Yellow RAL1034

