

NÁVOD / INSTRUCTION

SH48077 Maryland Mk.I./II.

'Warburton's War' 1/48

EN

At the end of 1937 US Army Air Force issued competition specification for new Attack category aircraft (attack/ light bomber). Four companies entered the competition and the winner was Douglas Company with its DB-7 (A-20 Havoc). Martin Co. focused on export. Even though its Model 167W wasn't accepted by USAAF, it was mass produced. The first order came from France for modified Model 167F. At all 257 machines were delivered. Martin 167 A-3 with non official name Glenn were assembled in Casablanca and subsequently assigned to combat units. Not all of them reached their destined units. During the Battle of France Glenns carried out 418 combat flights and 18 machines, in total, were lost during air combats. Other machines were lost on ground and the rest flown over to Africa. They were used by both Vichy French Air Force and Free French Air Force. The additional orders were taken over by Great Britain. The small initial series of Martin 167F with French equipment was used for non combat purposes. Further series were produced according to British requirements. Britain designated them Maryland Mk.I (R-1830 SC3G engines with single stage superchargers) and Maryland Mk.II (R-1830 S3C4G engines with double stage superchargers). Both versions served with FAA, RAF and SAAF. One of the FAA no. 771 Squadron machines spotted Bismarck departing its anchorage in Norway. RAF and SAAF deployed their Marylands mainly in MTO, Malta and Africa. The assignment varied from bomber, reconnaissance to night fighter missions. During 1942 were Marylands subsequently withdrawn from active duty.

Wingspan: 18.69 m, Length: 14.22 m, Max. Speed: 485 kmh, Service Ceiling: 8,997 m (Mk.I)/ 9,448 m (Mk.II), Range with bomb load: 1,635 km.

CZ

Na konci roku 1937 vypsal armádní letectvo USA soutěž na nový letoun kategorie Attack (útočný/lehký bombardovací). Do soutěže se přihlásily čtyři firmy, vítězem se stala firma Douglas se svým DB-7 (A-20 Havoc). Firma Martin se ale soustředila na exportní objednávky, takže i přes to, že její model 167W nebyl přijat do výzbroje letectva US Army, vyráběl se sériově. Jako první si objednala dle svých požadavků upravený model 167F Francie. Ta dostala celkem 257 kusů. Pod označením Martin 167A-3 a neoficiálním jménem Glenn byly nové stroje montovány v Casablance a postupně zařazovány k bojovým jednotkám. Tam se nedostaly zdaleka všechny. V bitvě o Francii provedly Glenny 418 bojových vzletů, celkem bylo ztraceno ve vzdušných bojích 18 strojů. Další byly zničeny na zemi a zbylé ulétly do Afriky. Dostaly se do výzbroje jak Vichistické Francie, tak Svobodných Francouzů. Další objednávky převzala Velká Británie. Po malé sérii Martinů 167F s francouzským vybavením, která byla použita k nebojovým účelům byly stroje z dalších objednávek vybaveny dle britských požadavků. Británie používala tyto stroje jako Maryland Mk.I (s motory R-1830 SC3G s jednostupňovými kompresory) a Maryland Mk.II (s motory R-1830 S3C4G s dvoustupňovými kompresory). Sloužily jak u FAA, např. jeden stroj z No.771 Sq. FAA zjistil, že Bismarck opustil kotviště v Norsku, tak u RAF a SAAF. RAF a SAAF nasadilo své Marylandy hlavně ve Středomoří, na Maltě a v Africe. Spektrum použití bylo velmi široké, od bombardování a průzkumu až k nočnímu stíhání. Během roku 1942 byly postupně vyřazovány.

rozpětí: 18,69 m, délka: 14,22 m, max. rychlost: 485 km/h, dostup: 8 997 m (Mk.I)/9448 m (Mk.II), dolet s pumovým nákladem 1635 km

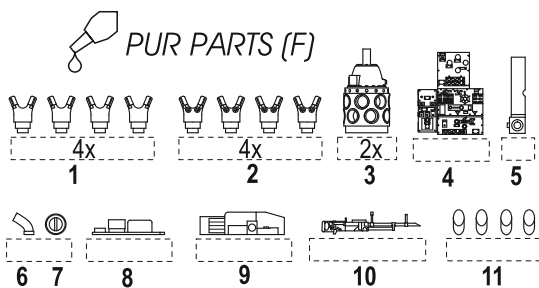
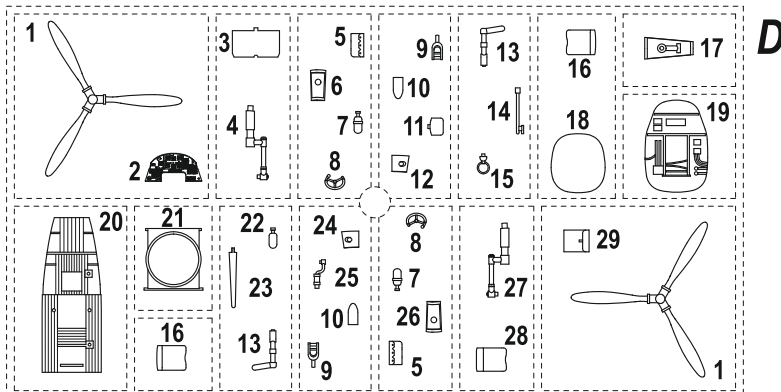
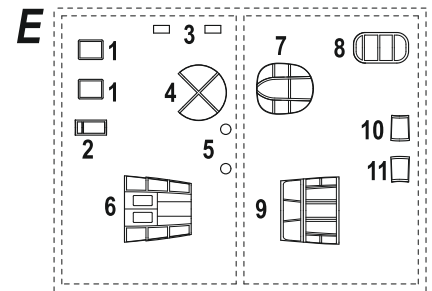
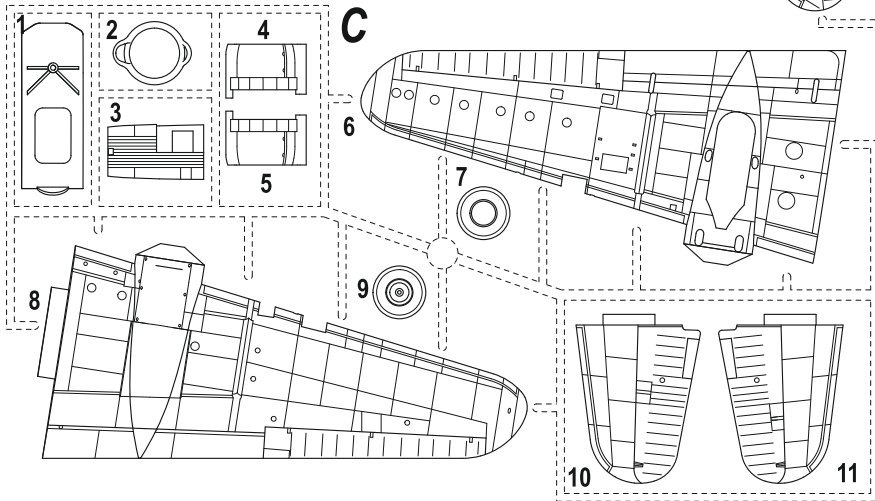
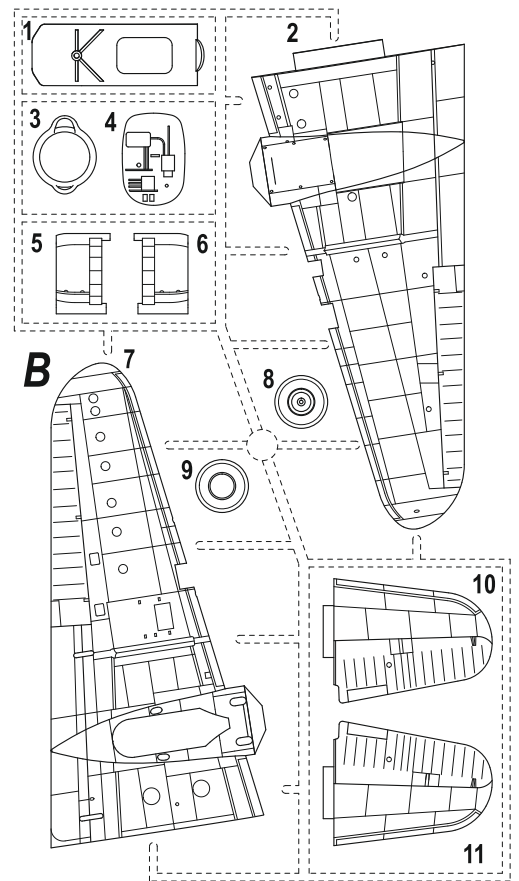
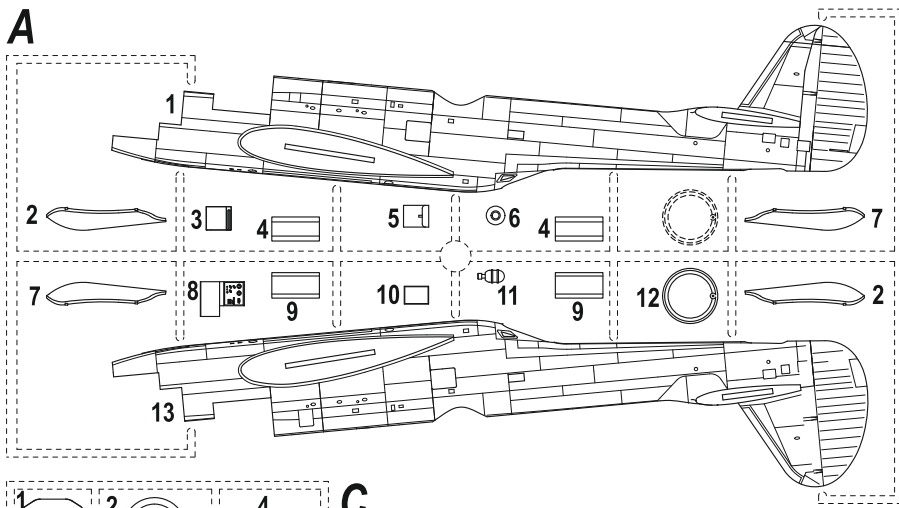



 Vyrobit
Scratch build
Fertigstellen
Achever

 PHOTOETCHED PARTS (L)

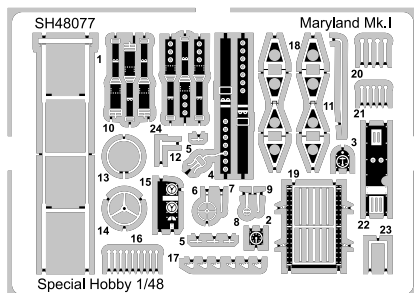
 Lepidlo na kov
Glue for metal
Metallkleber
Colle a metal



 Ohnout
Bend
Biegen
Courber

 Možnost volby
Optional
Nach belieben
Option

 Oddělit
Cut with knife
Mit Messer schneiden
Couper au couteau

- | | |
|-------------|-------------------------------------|
| H12 / C33 | Matt Black / Matná černá |
| H17 / C29 | Dark Brown / Hnědá |
| H27 / C44 | Tan / Plátno |
| H52 / C12 | Olive Drab / Olivová |
| H57 / C73 | Aircraft Grey / Šedá |
| H58 / C27 | Interior Green / Interiérová zelená |
| H72 / C22 | Earth Brown / Zemité hnědá |
| H73 / C23 | Dark Green / Tmavá zelená |
| H74 / C26 | Sky / Nebeská modrá |
| H76 / C61 | Burnt Iron / Opálený kov |
| H77 / C137 | Tire Black / Černá na pneumatiky |
| H313 / C313 | Sand / Písková |
| H314 / C314 | Light Blue / Light Blue |
| H329 / C329 | Yellow / Žlutá |
| H337 / C337 | Dark Blue-grey / Tmavá modrošedá |
| C370 | Azure Blue / Azurová modrá |
| MC213 | Stainless / Ocelová |
| MC214 | Dark Iron / Černá kovová |
| MC218 | Aluminium / Hliníková |



1

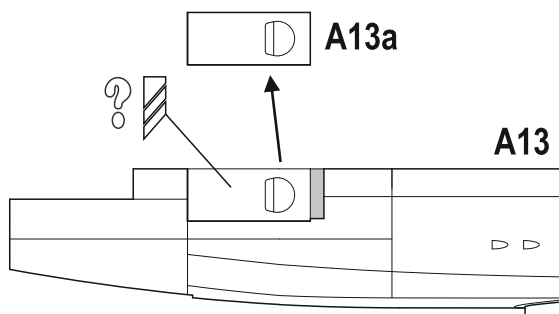
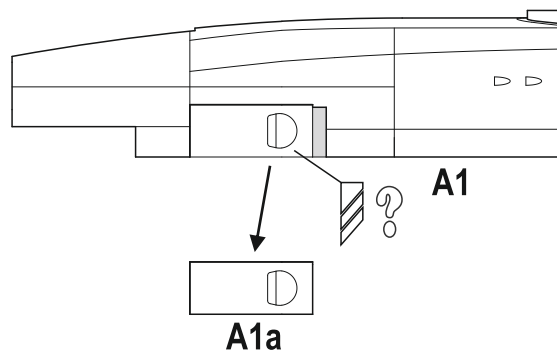
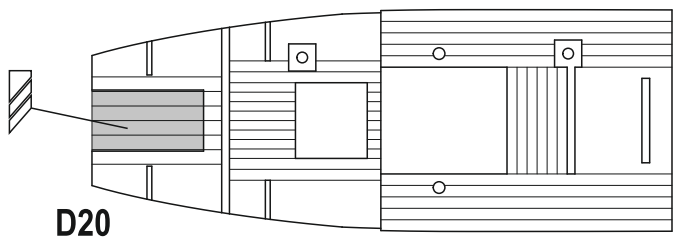

2

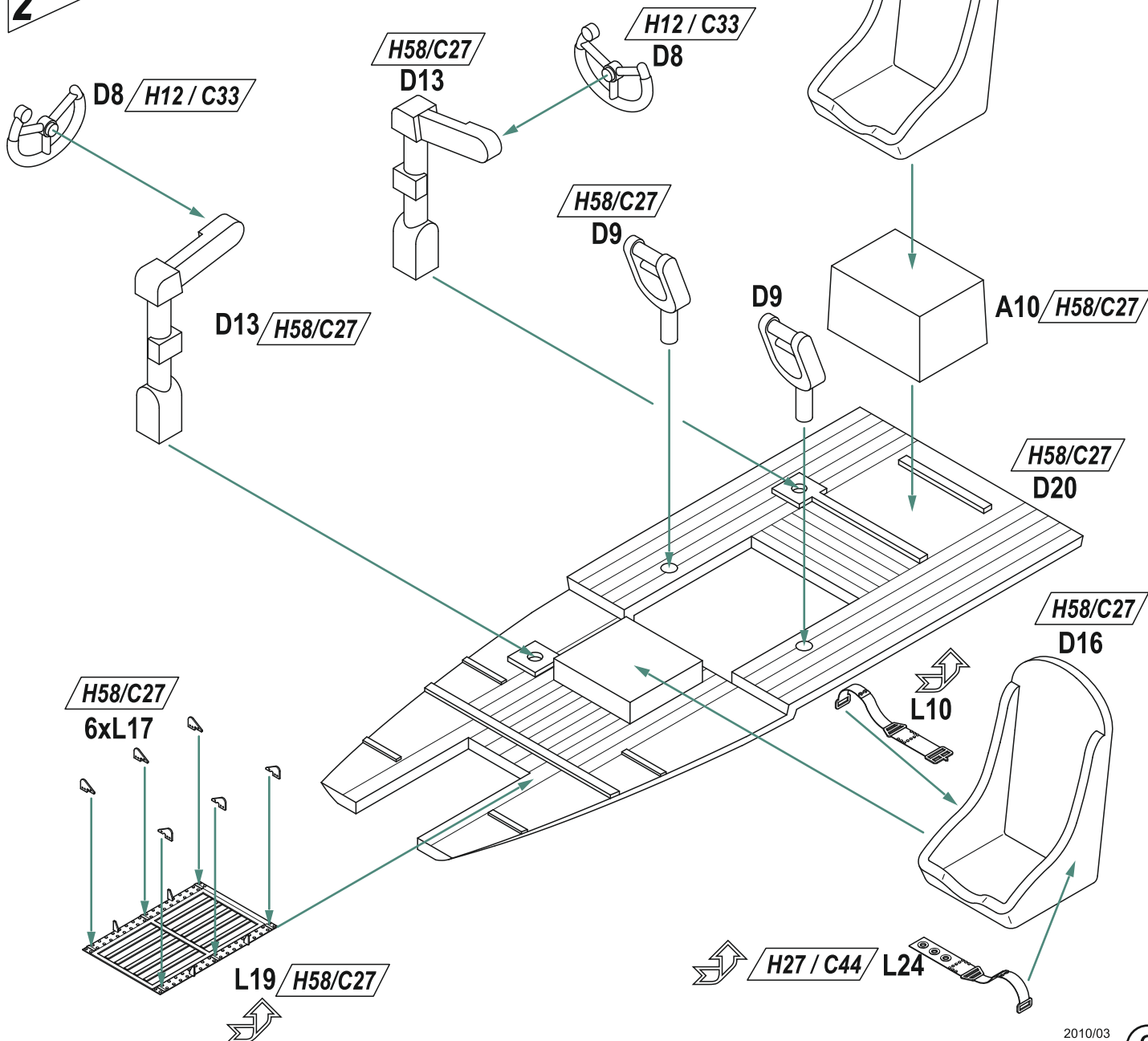

STEP4

2010/03

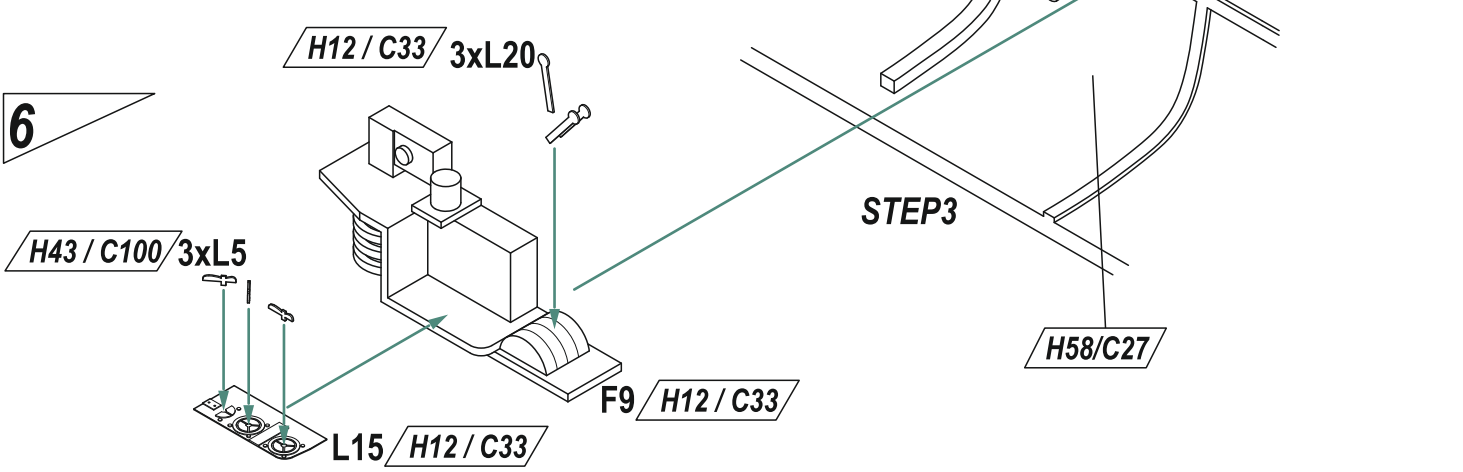
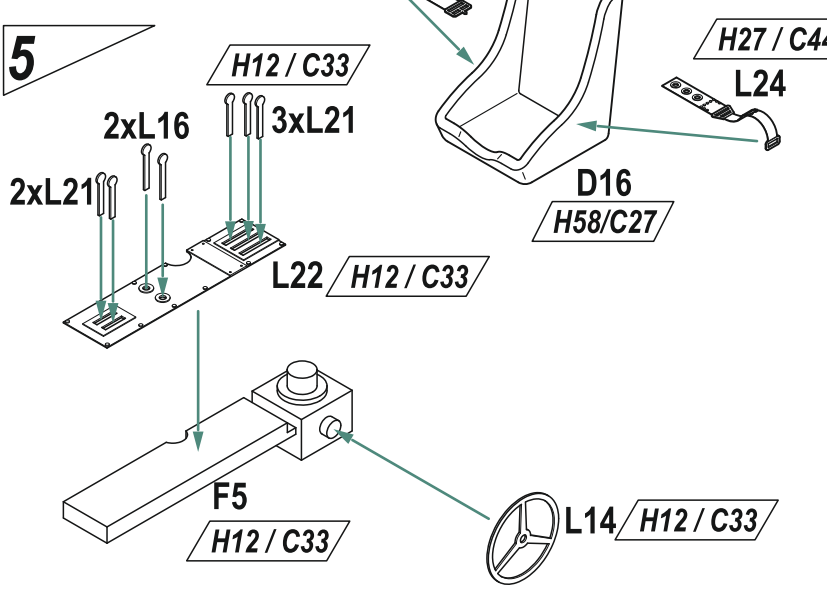
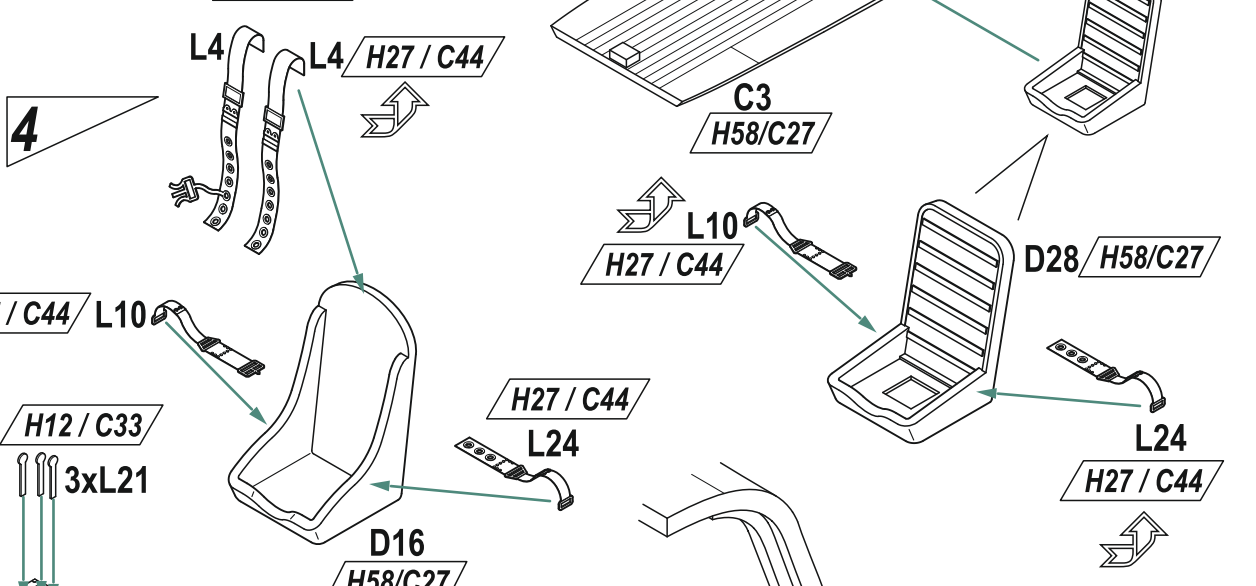
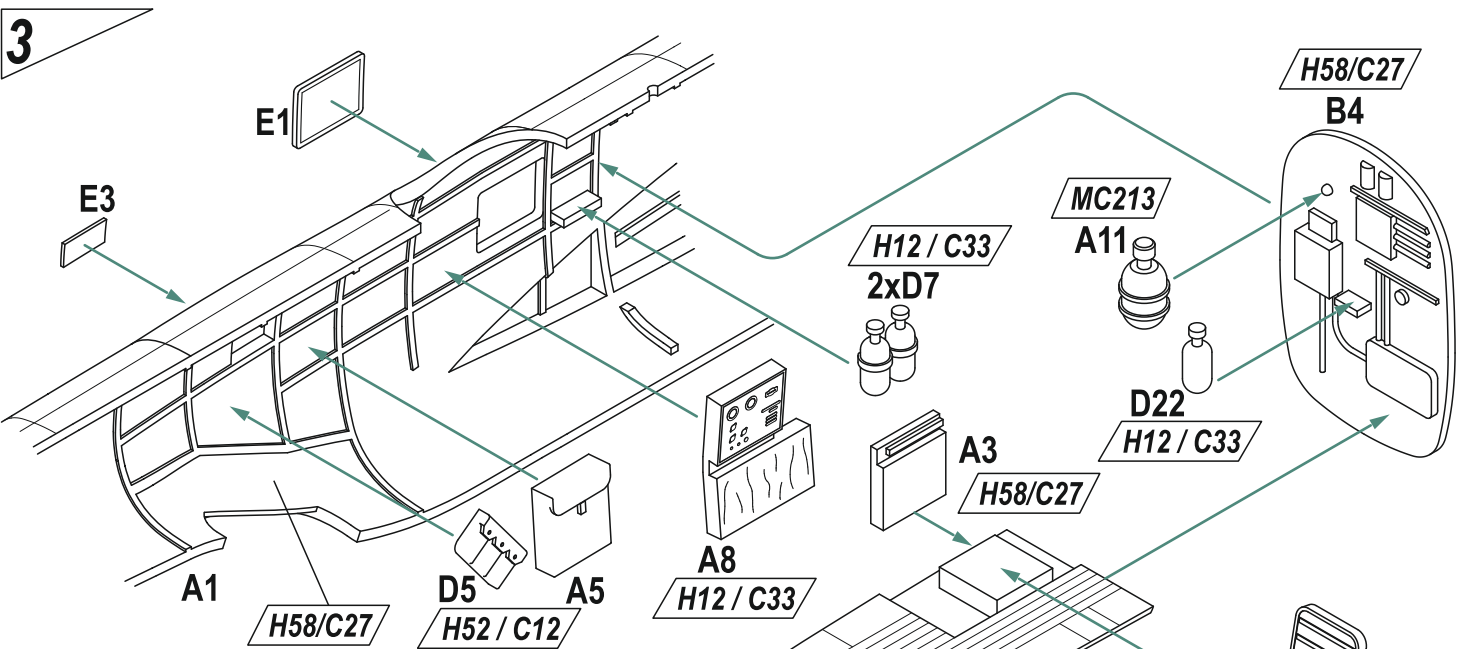

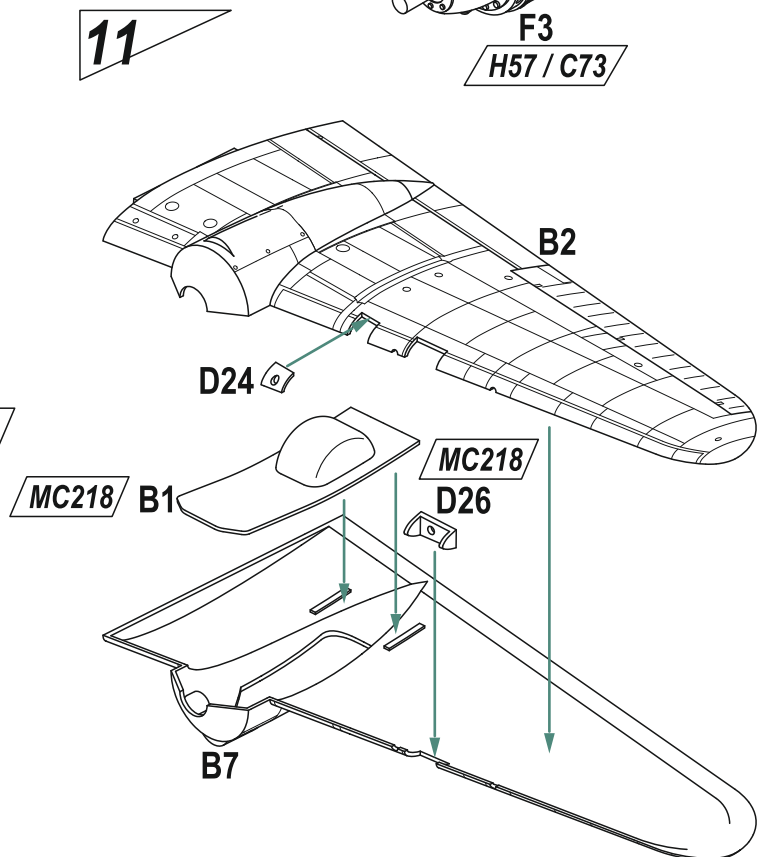
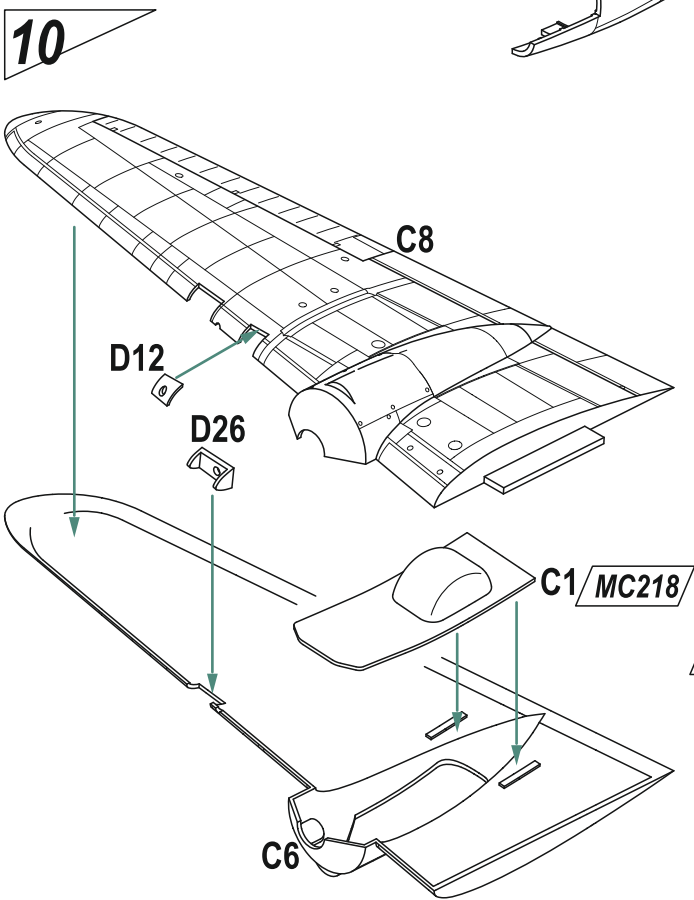
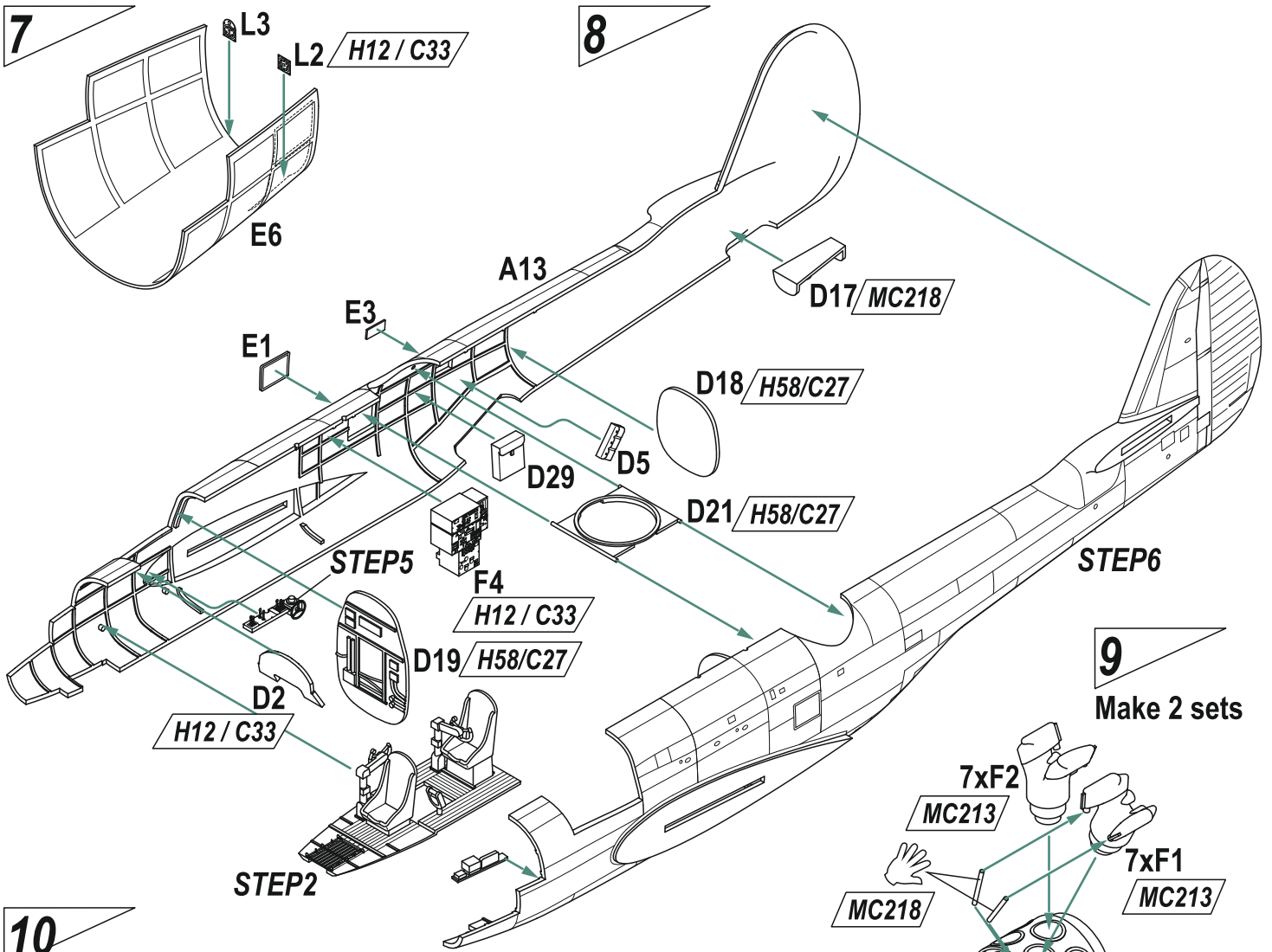

12

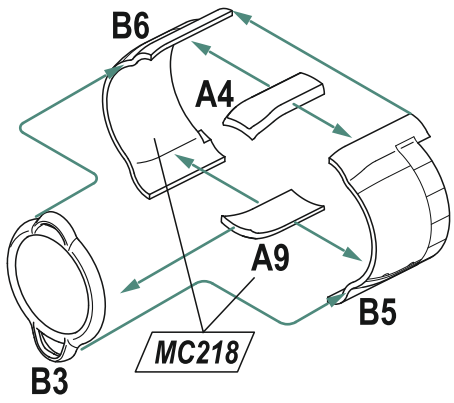

13

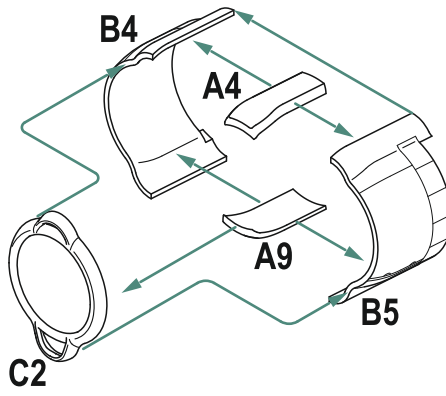

14

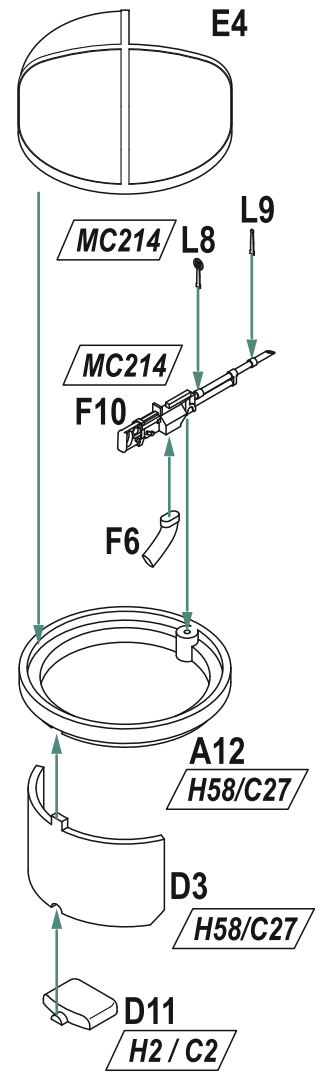

15

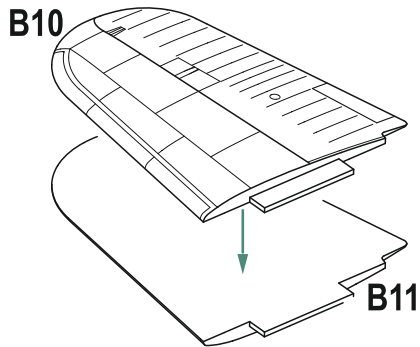

16

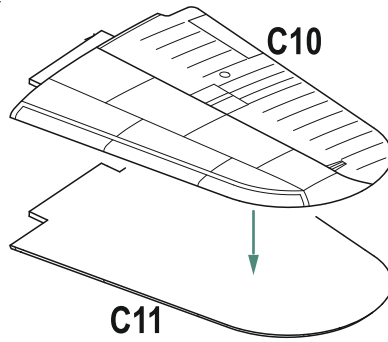

17

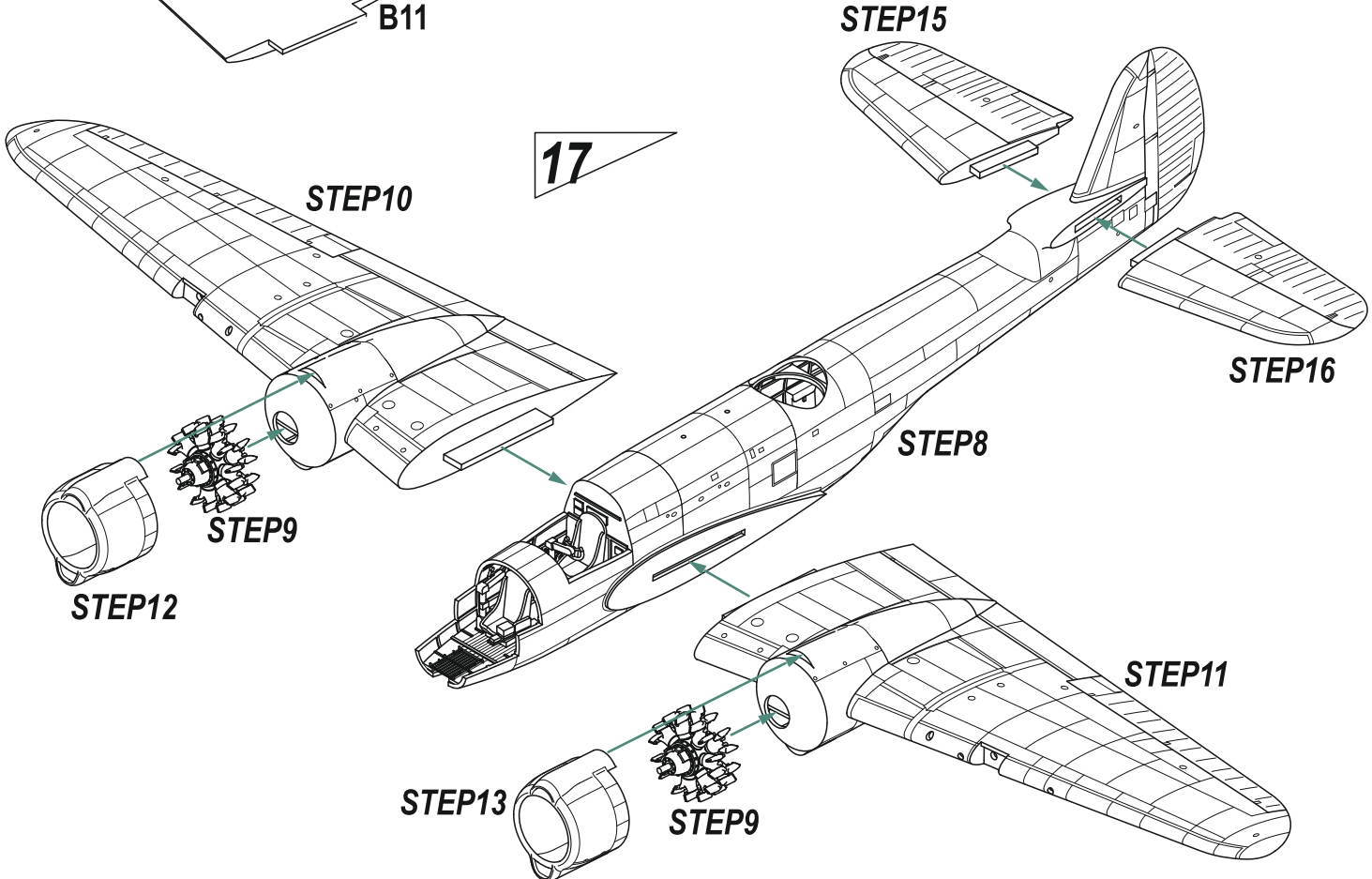

18

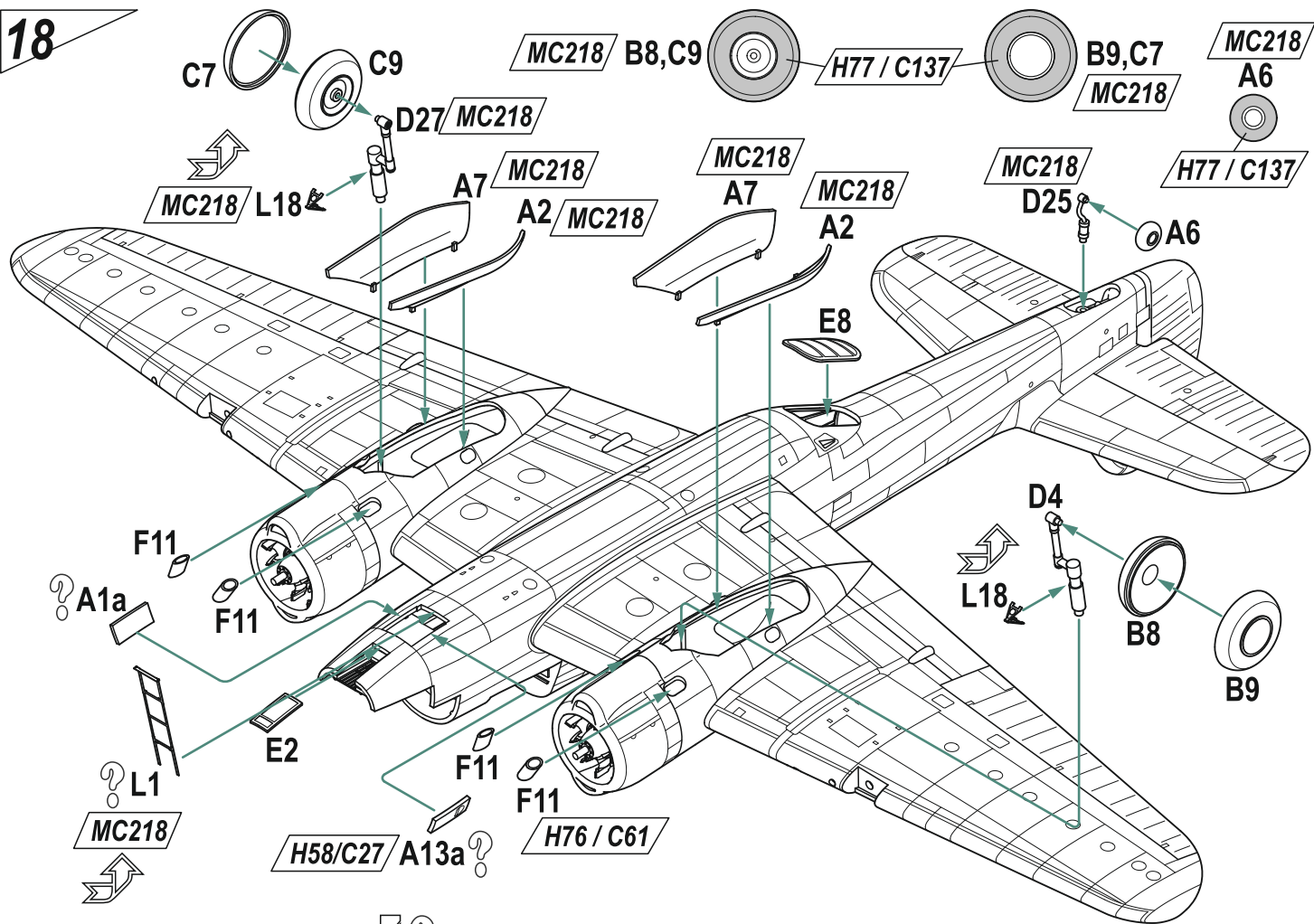

19

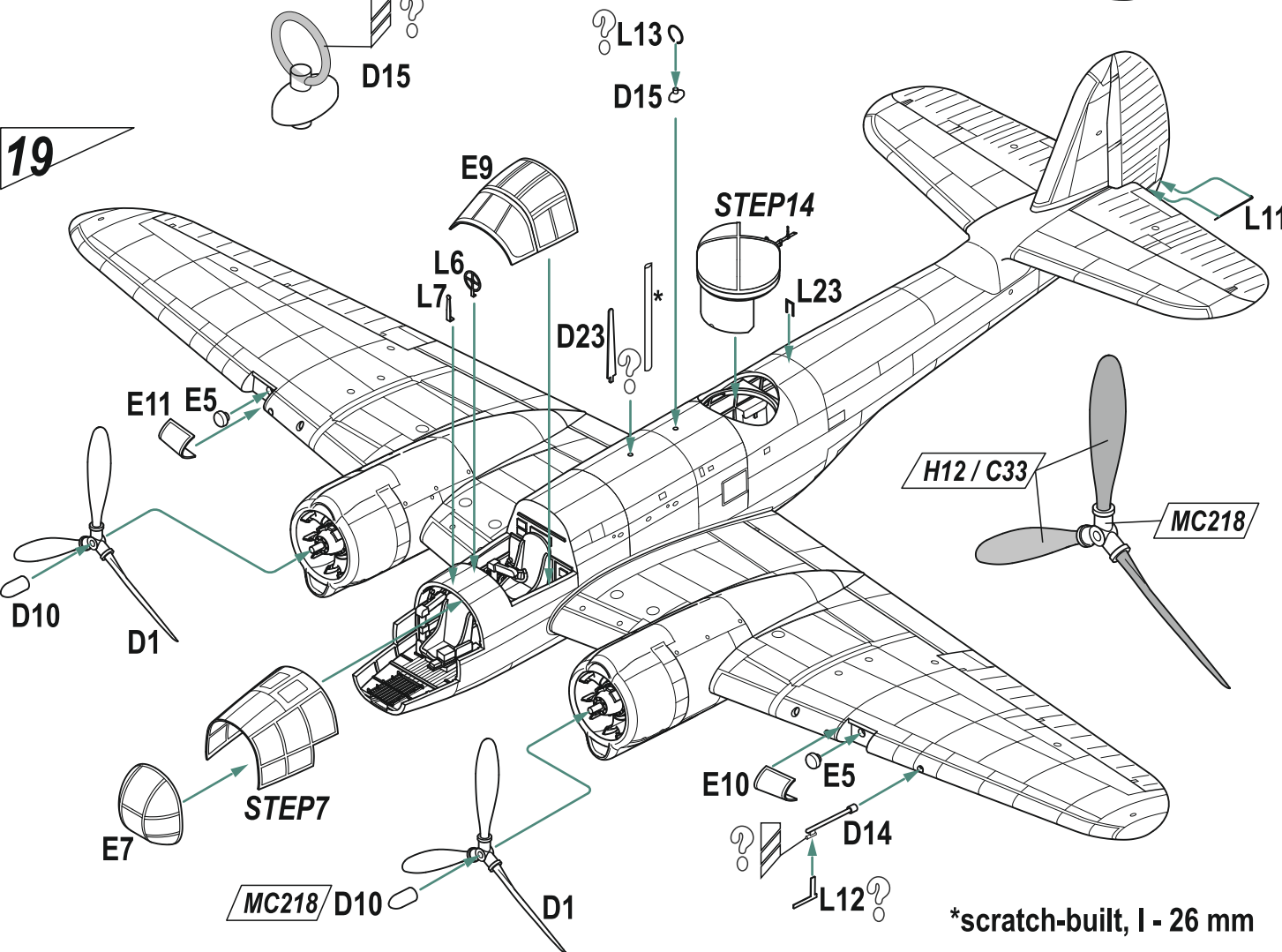

*scratch-built, l - 26 mm

Martin 167F No.114, bílá „2“, No 69 Sq. RAF, pilot A. Warburton, letiště Luqa, Malta, květen 1941. S tímto strojem, patřícím původně GR I/22 letectva Vichy uletěla dne 10. února 1941 na Gibraltar osádka pilot Sgt. Brugère, Lt. Giradou a Sgt. Varasseur, aby mohli přidat k FFL. Stroj byl převeden k No 69 Sq. RAF na Maltu, kde s ním létal A. Warburton. Stroj zůstal v původní francouzské kamufláži, přetřeny byly jen znaky. Na kýlovku byl doplněn fin flash. Původní francouzská trikolóra na kormidle svislé ocasní plochy byla přetřena barvou Dark Earth. Francouzské Martiny 167F byly dodávány v barvě kovu a kamuflážní barvy byly stříkány přímo na neošetřený povrch. Barva se značně loupala a to byl případ i tohoto stroje.

Martin 167F No.114, White „2“, RAF No 69 Squadron, pilot A. Warburton, Luqa airfield, Malta, May 1941. This machine that originally belonged to Vichy AF, GR I/22 unit was used by crew of Sgt. Brugère, Lt. Giradou and Sgt. Varasseur to run over to Gibraltar where they can join FFL. The machine was assigned to RAF No 69 Squadron based at Malta where it was used by A Warburton. The machine remained its French camouflage, only the national insignias were over painted. British fin flash was applied to the fin and the original French one on rudder was over painted. French Martin 167Fs were delivered in natural metal finish and camouflage was applied to this non primed surface. It led to the extensive paint chipping and it was also this peculiar to this machine.

CAM. A

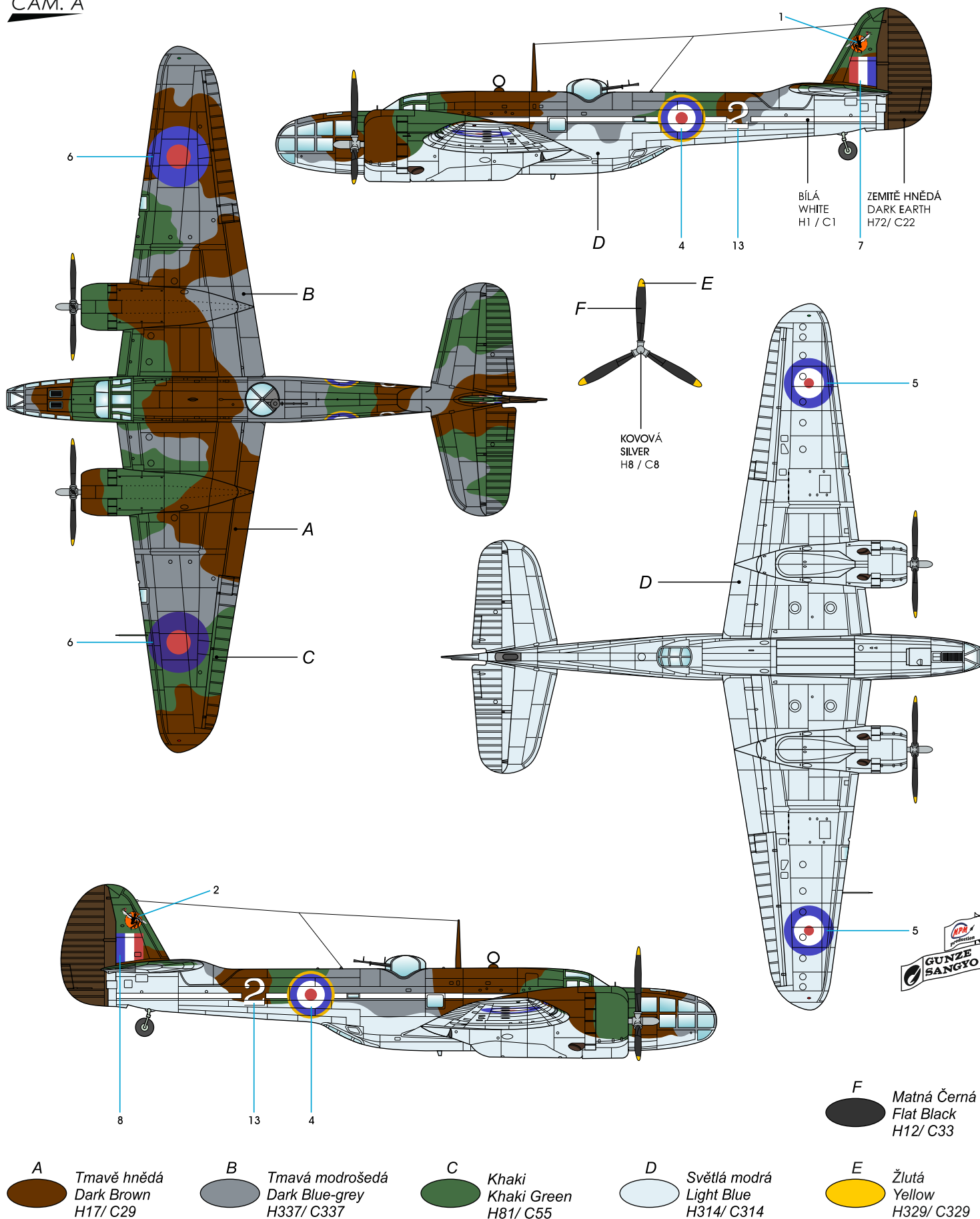

CAM. B

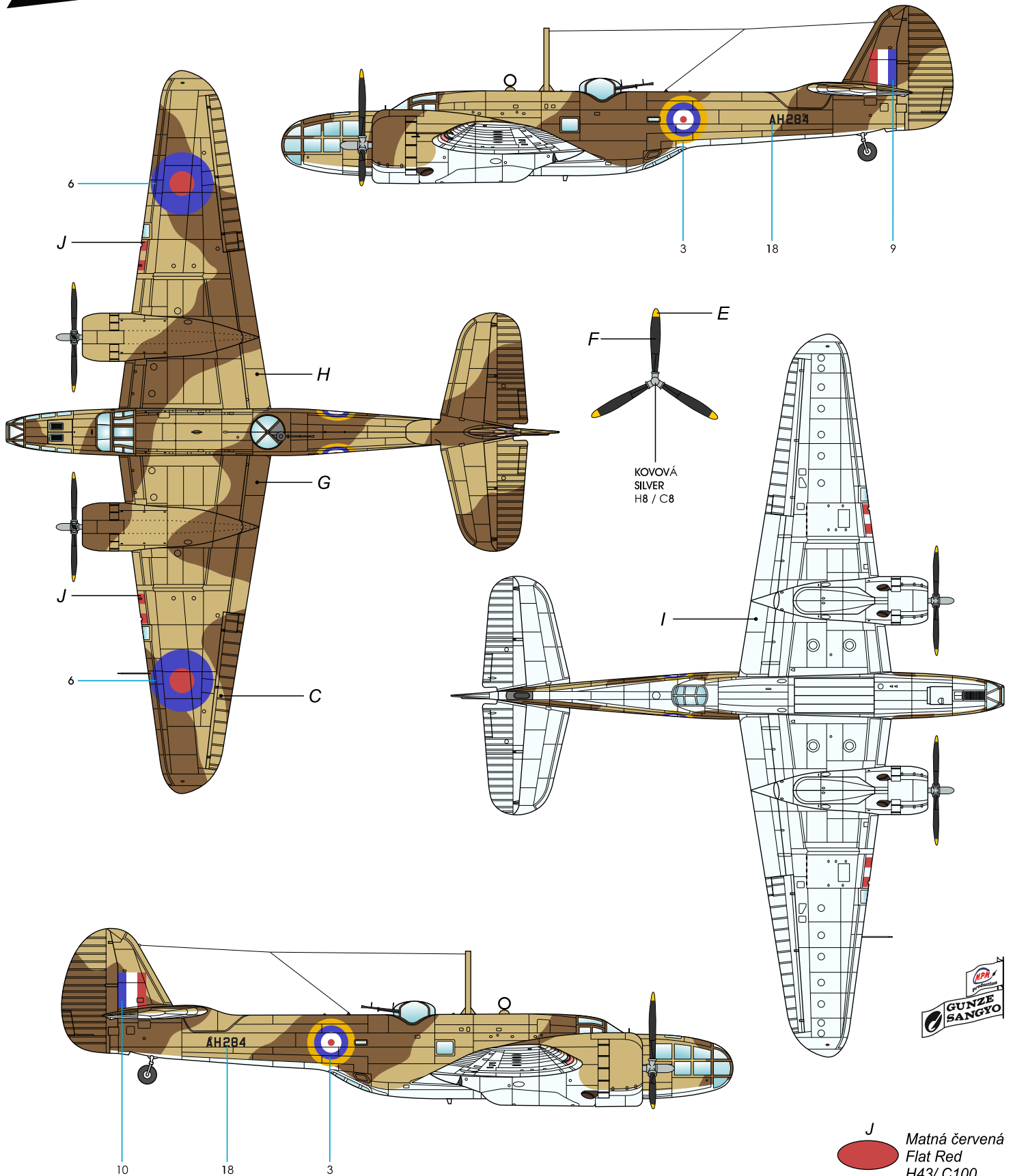

G Zemité hnědá
Earth Brown
H72/ C22

H Písková
Sand
H313/ C313

I Azurová modrá
Azure Blue
C370

E Žlutá
Yellow
H329/ C329

J Matná červená
Flat Red
H43/ C100

F Matná černá
Flat Black
H12/ C33

Maryland Mk.I, 1654, červené „X“, No 24 Sq. SAAF, Západní poušť, Afrika, konec roku 1941. Stroj byl patrně původně v evropské kamufláži a byl přestříkán pouštními barvami. Poslední čtyřčíslí z sériového čísla bylo nastříkáno v obdélníku původní barvy Dark Green. Poslední dvojčíslí bylo zopakováno v bílých obdélnících na obou stranách přídě.

Maryland Mk.I, 1654, Red „X“, SAAF No 24 Squadron, Western Desert, Africa, end of 1941. The machine most probably wore European camouflage that was later over painted by Desert colors. The last four digits of the serial number were applied on Dark Green rectangle. Last two digits of the serial number were applied to the white rectangles on both sides of the nose.

CAM. C

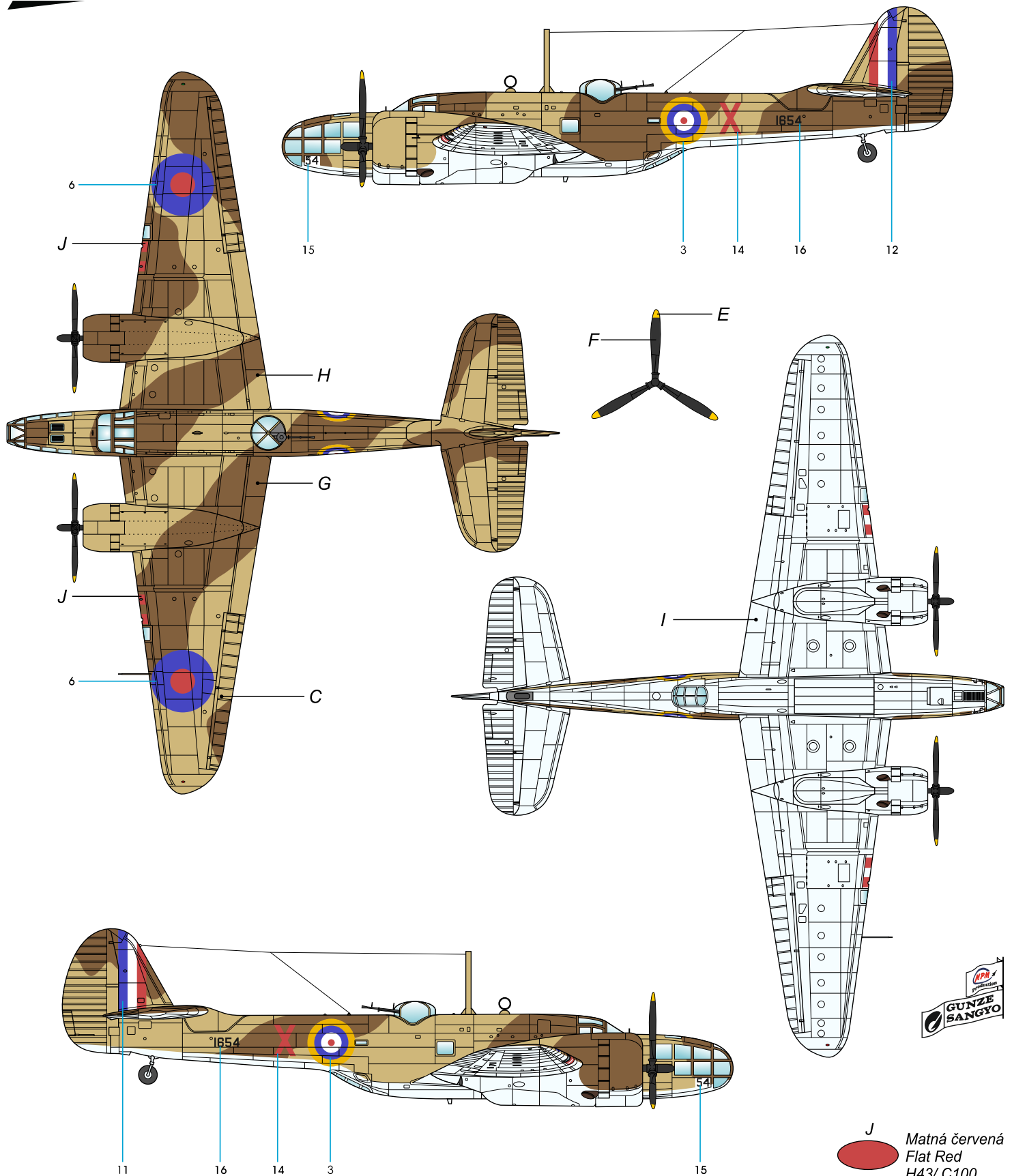

G Zemitě hnědá
Earth Brown
H72/ C22

H Písková
Sand
H313/ C313

I Azurová modrá
Azure Blue
C370

E Žlutá
Yellow
H329/ C329

F Matná Černá
Flat Black
H12/ C33

J Matná červená
Flat Red
H43/ C100

Maryland Mk.I, AR733, No 69 Sq. RAF, letiště Luqa, Malta, leden 1942. Také tento stroj používal mimo jiných pilotů A. Warburton. 12. února 1942 byl tento stroj zasažen Bf 109 (pravděpodobně Lt Schramm od 8/JG53) a vážně poškozen a nouzově přistál. Střelec Sgt. Moore byl zabit střelbou Bf 109, pilot P/O Channon a navigátor Sgt. Watson vyvázli nezcraněni. Za úspěšnou obranu letounu byl navigátor vyznamenán DFM.

Maryland Mk.I, AR733, RAF No 69 Squadron, Luqa airfield, Malta, January 1942. This machine was used, except of other pilots, by A Warburton. On February 12, 1942 was this machine severally damaged by Bf 109 (probably Lt. Schramm from 8/JG53) and had to make emergency landing. The gunner Sgt. Moore was killed by the Bf 109 fire but pilot P/O Channon and navigator Sgt. Watson escaped unhurt. The navigator was credited with DFM for the successful defense of the aircraft.

CAM. D

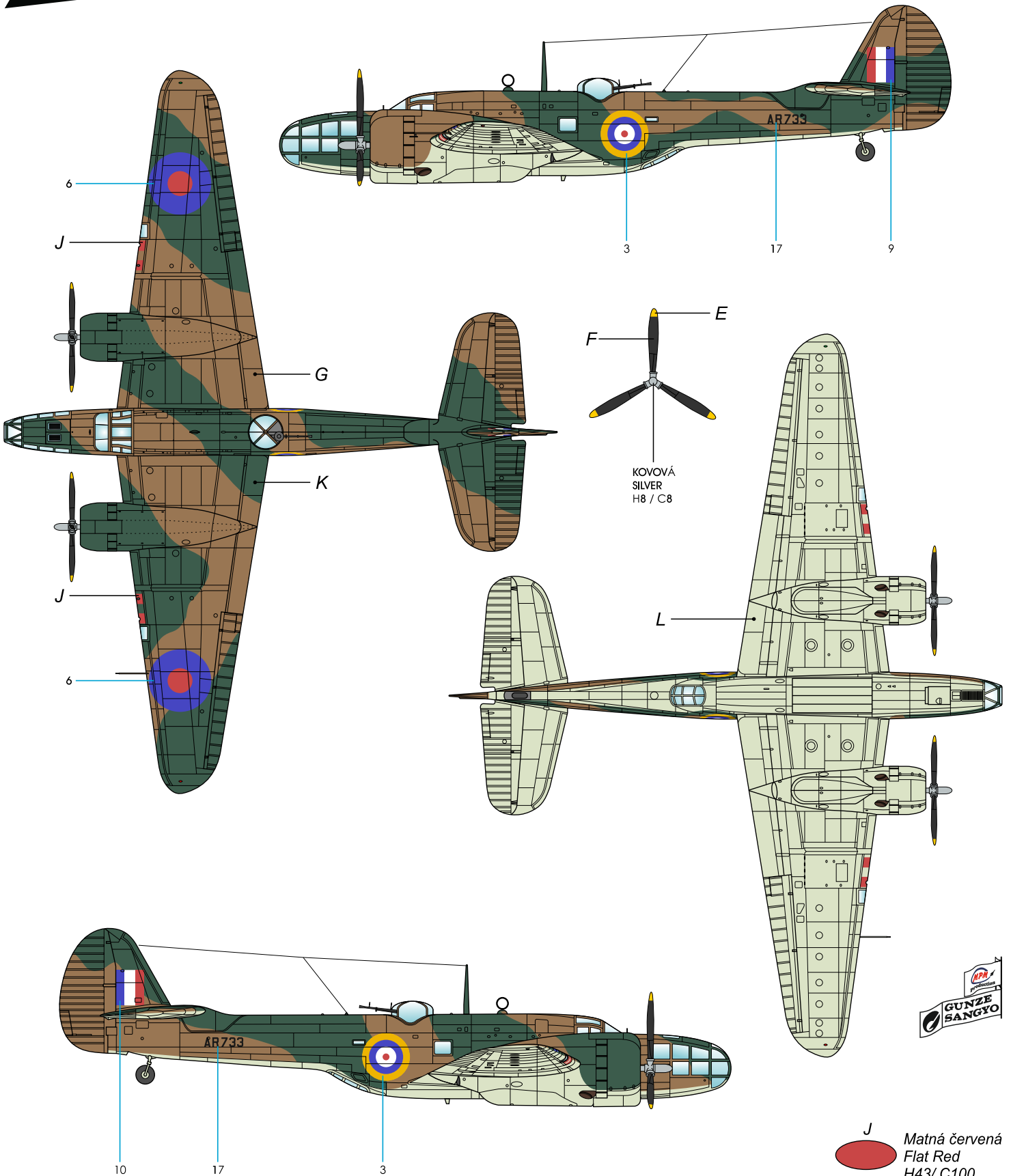

- | | | | | | |
|---|--|--|---|--|---|
| <p>G Zemité hnědá
Earth Brown
H72/ C22</p> | <p>L Nebeská modrá
Sky
H74/ C26</p> | <p>K Tmavá zelená
Dark Green
H73 /C23</p> | <p>E Žlutá
Yellow
H329/ C329</p> | <p>J Matná červená
Flat Red
H43/ C100</p> | <p>F Matná černá
Flat Black
H12/ C33</p> |
|---|--|--|---|--|---|

ATTRACTIVE 1/48 SCALE MODELS

RESIN SETS & MASKS

4452
Main Wheels



P48002
Engine



M48015
J-3 Cub
Inside/Outside MASK

Special
MASK

SH48220
J-3 'Cub Goes to War'



M48017
Grunau Baby IIB Mask
Canopy, Fabric Flying / Control Surfaces

Special
MASK

SH48237
Grunau Baby IIB 'German WWII Glider'

AND 3D PRINTED SETS

P48004
Yak-9D Exhausts

3D-Printed Parts

© Special Hobby 2022

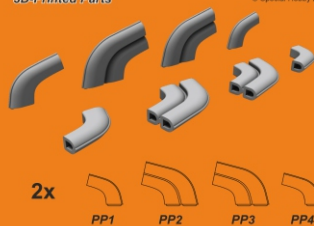

2x

PP1

PP2

PP3

PP4



P48005
1/48
Tempest Mk.II Engine
(Centaurus)

Contains detailed 3D printed parts and resin parts.
For Special Hobby a Eduard Kits.

P48007
B-25D Late/G/H/J
Mitchell Pilot Seats

PE - Photo-etched parts

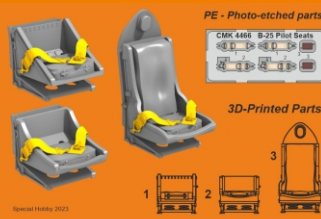

CMK 4465 B-25 Pilot Seats

3D-Printed Parts

1

2

3

Special Hobby 2022

P48008
Czech Hedgehog
(Rozsocháč)
- WWII Anti-tank Barrier (2 pcs)



3D-Printed Parts

2x

Special Hobby 2022

Special
HOBBY

facebook.com/specialhobby

WWW.SPECIALHOBBY.EU | WWW.CMKKITS.COM

CMK
CZECH
MASTER'S KITS