

### **Westland Whirlwind FB Mk.I "Fighter-Bomber"**

#### **CZ**

Na základě specifikací F.37/35, které požadovaly těžce vyzbrojenou stíhačku pro boj s bombardéry, vznikl u firmy Westland projekt P.9, dvomotorový stroj s výzbrojí čtyř kanonů ráže 20 mm. V únoru 1937 RAF uzavřelo s firmou Westland smlouvu na postavení dvou prototypů. První z nich, L6844 vzlétl poprvé 11. října 1938. Následovaly dva roky zkoušek, do kterých se zapojil i druhý prototyp L6845. Během těchto zkoušek se měnily hlavně ocasní plochy a byly zrušeny sloty. Sériové stroje se začaly vyrábět v roce 1940. Do výzbroje je dostala 263. squadrona RAF. V roce 1941 je dostala další jednotka 137. squadrona RAF. Další jednotky už tímto strojem vyzbrojeny nebyly. Na vině byly hlavně motory R&R Peregrine. Byly nespolehlivé a navíc jejich produkce byla zastavena ve prospěch potřebnějších Merlinů. To vedlo i k zastavení výroby Whirlwindů. Ty přitom byly rychlé a obratné, údajně byly schopné vymanévrovat i jednomotorovou stíhačku. A při své silné výzbroji čtyř kanonů představovaly nebezpečného protivníka. Jejich silná výzbroj byla později posílena i montáží závěsníků bomb pod křídlo. Takto upravené Whirlwindy byly označeny FB Mk.I nebo Mk.IA a nasazeny do bitevních akcí. Jejich úspěchy při útocích na německou loďní dopravu v Kanálu La Manche a v okupované Francii jim vynesly přezdívku Whirlbomber. Whirlwindy bojovaly v první linii do konce roku 1943, pak byly vyřazeny. Na prototypu L6844 byly testovány různé varianty výzbroje, např. dvanáct kulometů nebo kanon ráže 37 mm.

Rozpětí: 13,73 m, délka: 9,84 m, max. rychlost: 579 km/h, dolet: 1000 km, dostup: 9150 m.

#### **EN**

Project Wesland P.9 was designed upon F.37/35 Specifications that called for escort fighter with heavy armament. P.9 project was a twin engined aircraft with four 20 mm cannons. In February 1937 RAF and Westland signed a contract for manufacture of two prototypes. The first prototype L6844 took off for the first time on October 11, 1938. Following two years were both prototypes, the second was L6845, thoroughly tested and it subsequently led to the tail planes changes and deleting of slats. The production of the series machines began in 1940 and they were assigned to the RAF 263. Squadron. Another squadron, this time RAF 137. was equipped with Whirlwinds in 1941. Due to the R&R Peregrine engines no other units were equipped with Whirlwinds. These engines were unreliable and moreover their production was stopped on behalf of more needed Merlins. This also led to the production being stopped. Even though the Whirlwinds were fast, highly maneuverable and reputedly they were even capable to outmaneuver single engined fighter. Further, the heavy armament consisting of four cannons made the Whirlwind deadly opponent. The heavy armament was later intensified by addition of two wing mounted bomb racks. These modified Whirlwinds were designated FB Mk.I or Mk.IA and were used for ground attack missions. Their successful attacks on German ships in La Manche Channel and in occupied France earned them a nickname Whirlbomber. Whirlwinds fought in first line combat until the end of 1943 and then were withdrawn. The L6844 prototype was used as test bed for various armament layouts, such as 12 machine guns or 37 mm cannon.

Wingspan: 13.73 m, length: 9.84 m, max. speed: 579 km/h, range: 1,000 km, service ceiling: 9,150 m.

# DÍLY - PARTS - TEILE - PIECES

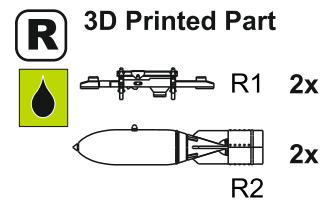
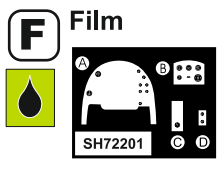
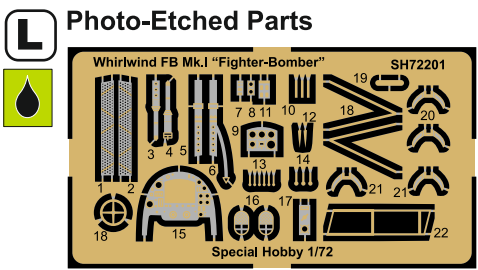
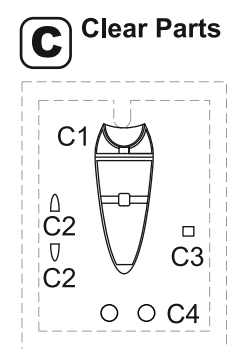
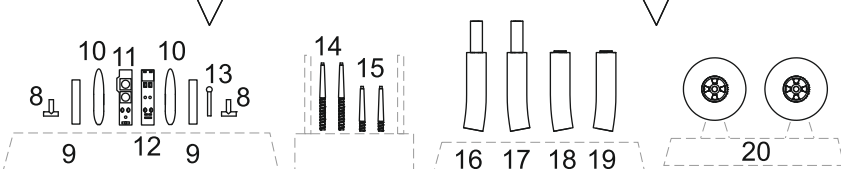
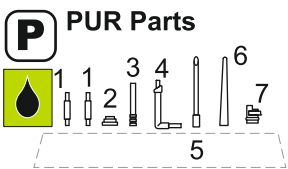
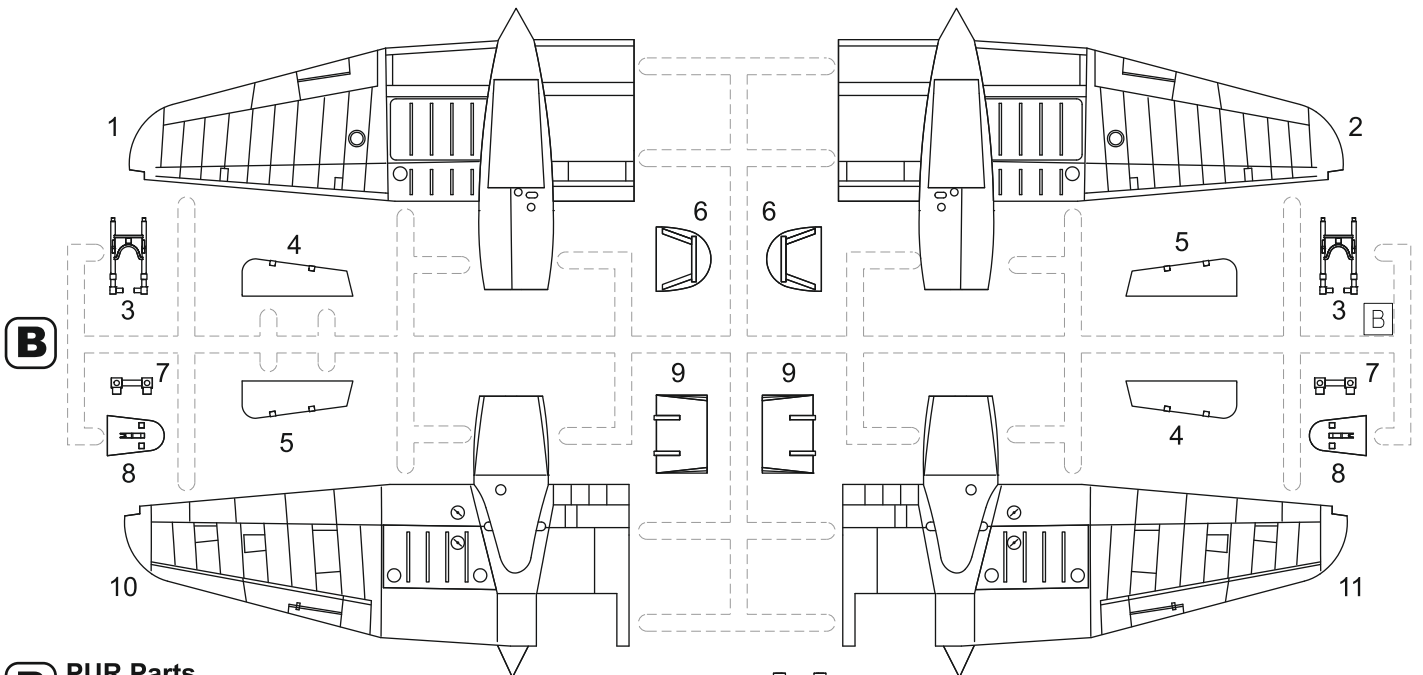
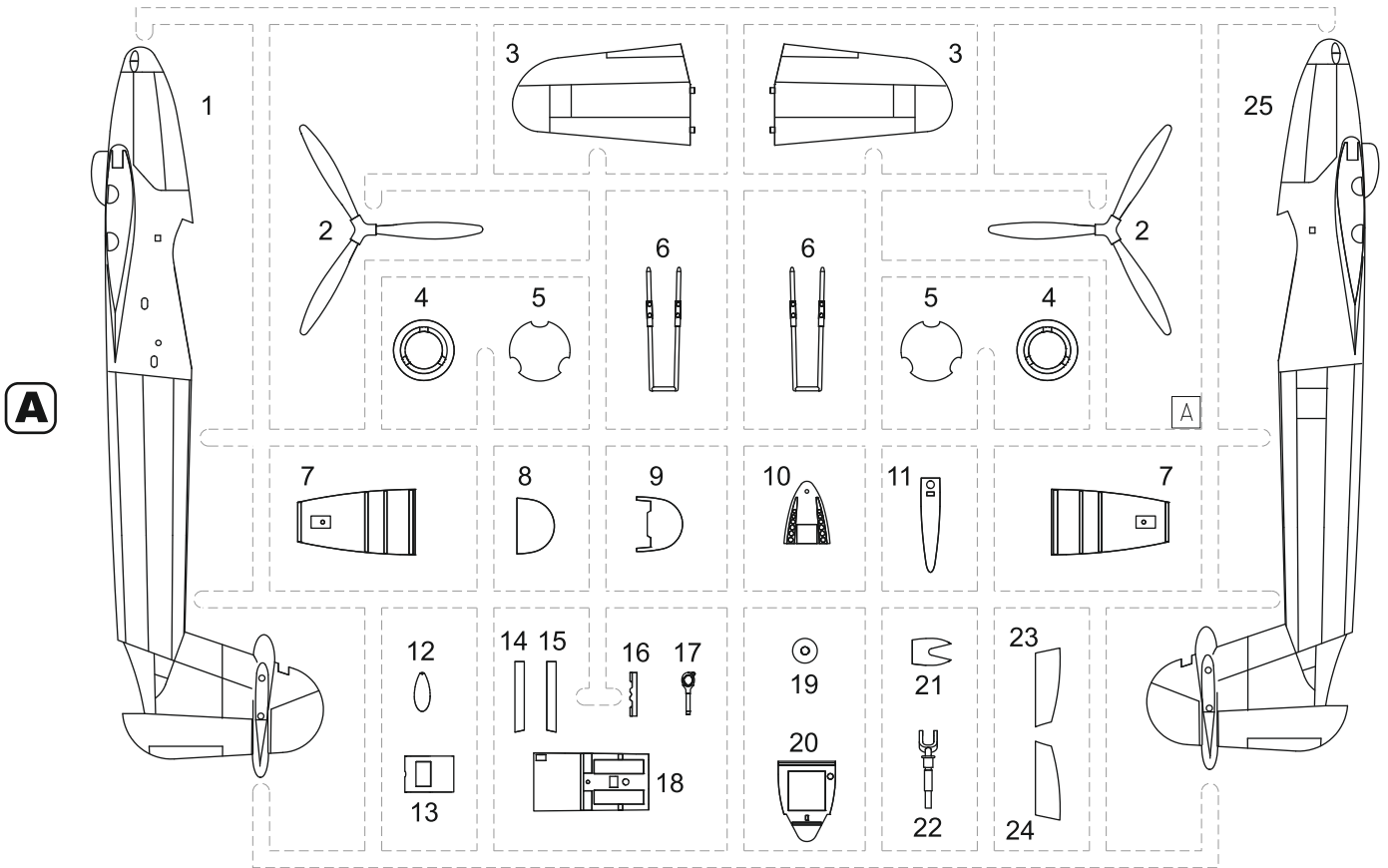

**?** MOŽNOST VOLBY  
OPTIONAL  
NACH BELIEBEN  
OPTION

**👉** POUŽIT KYANOAKRYLÁTOVÉ LEPIDLO  
INSTANT CYANOACRYLATE GLUE  
ZYANOAKRYLATKLEBER  
COLLE CYANOACRYLAT

**↩** OHNOUT  
BEND  
BIEGEN  
COURBER

**👉** ZHOTOVIT NOVÉ  
SCRATCH BUILD  
FERTIGSTELLEN  
ACHEVER

**🔪** ŘEZAT/VRTAT  
CUT OFF/DRILL  
ENTFERNEN  
DETACHER

**🎨** GSI  
colour code

**🎨** NATRÍT  
COLOUR  
FARBEN  
PEINDRE

**SESTAVA - ASSEMBLY - BAUANLEITUNG - ASSEMBLAGE**

**1**

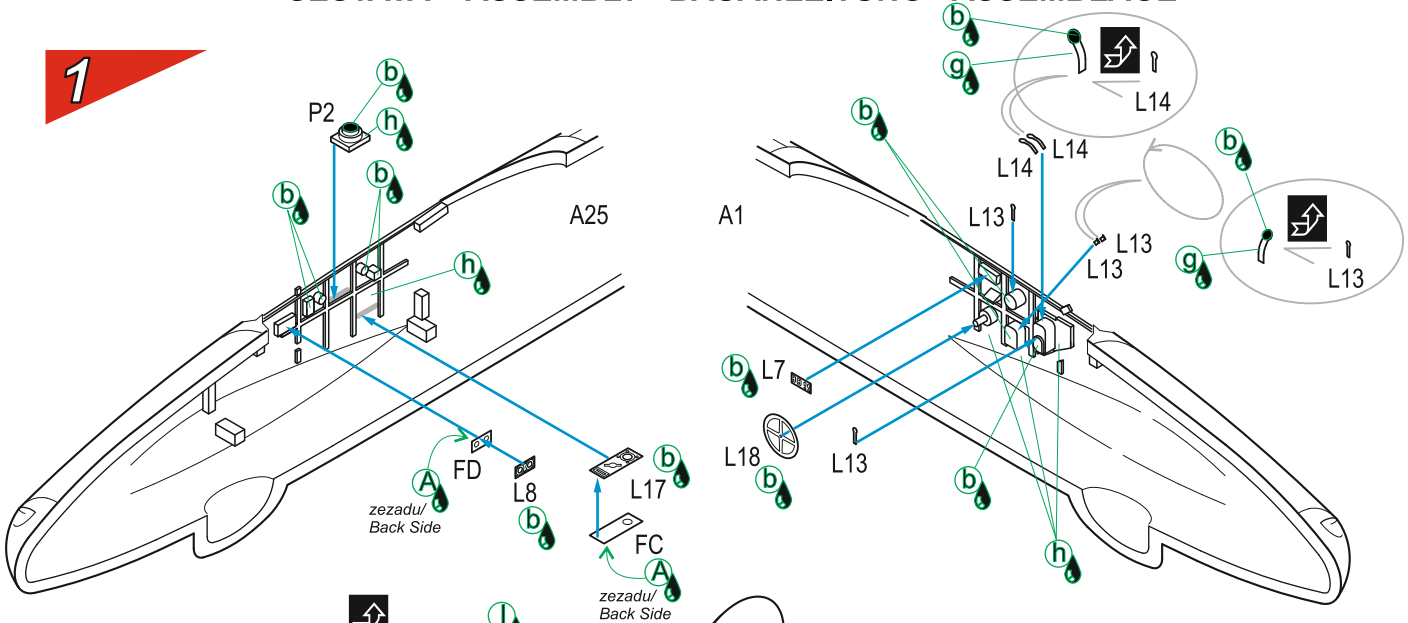

**2**

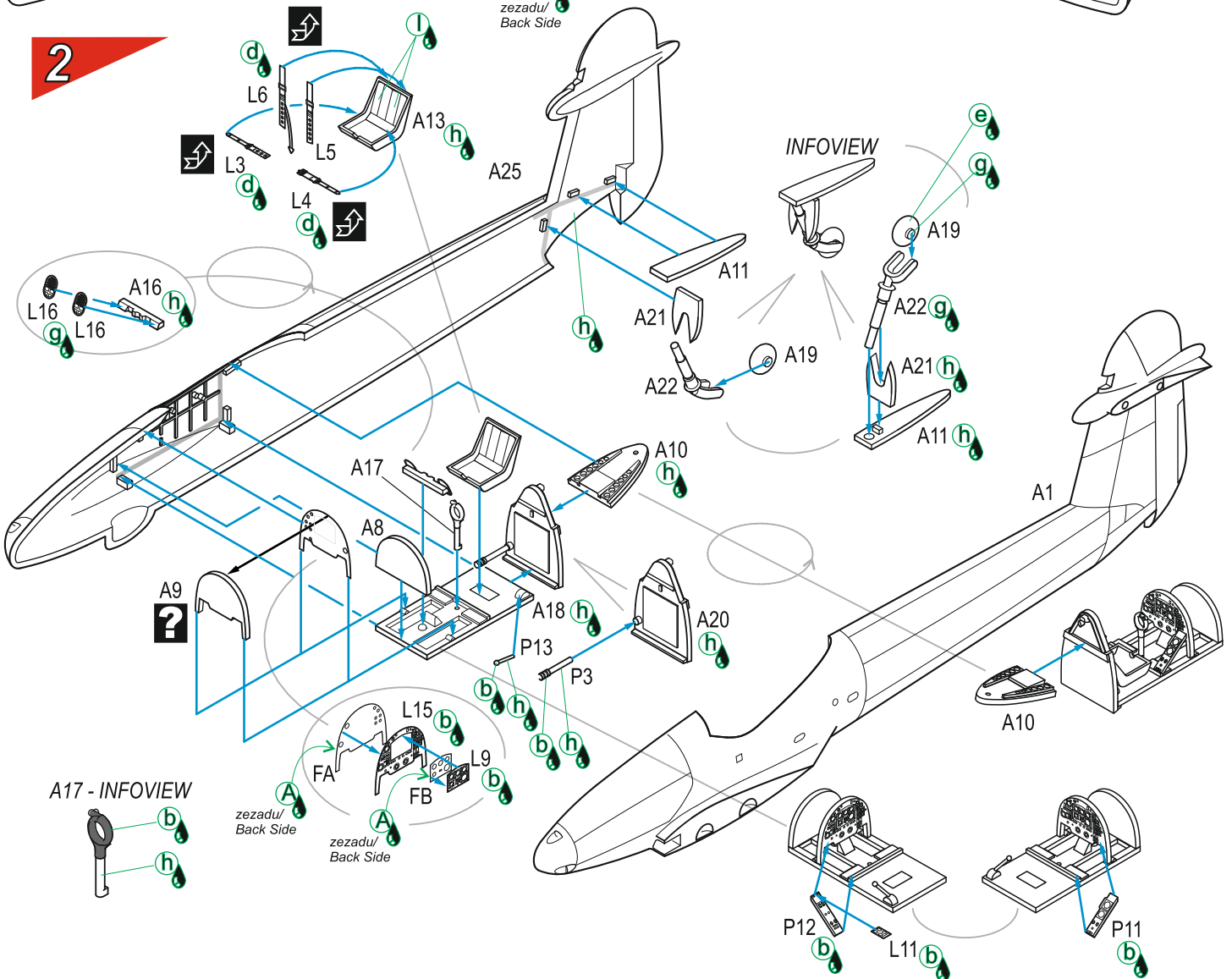

3

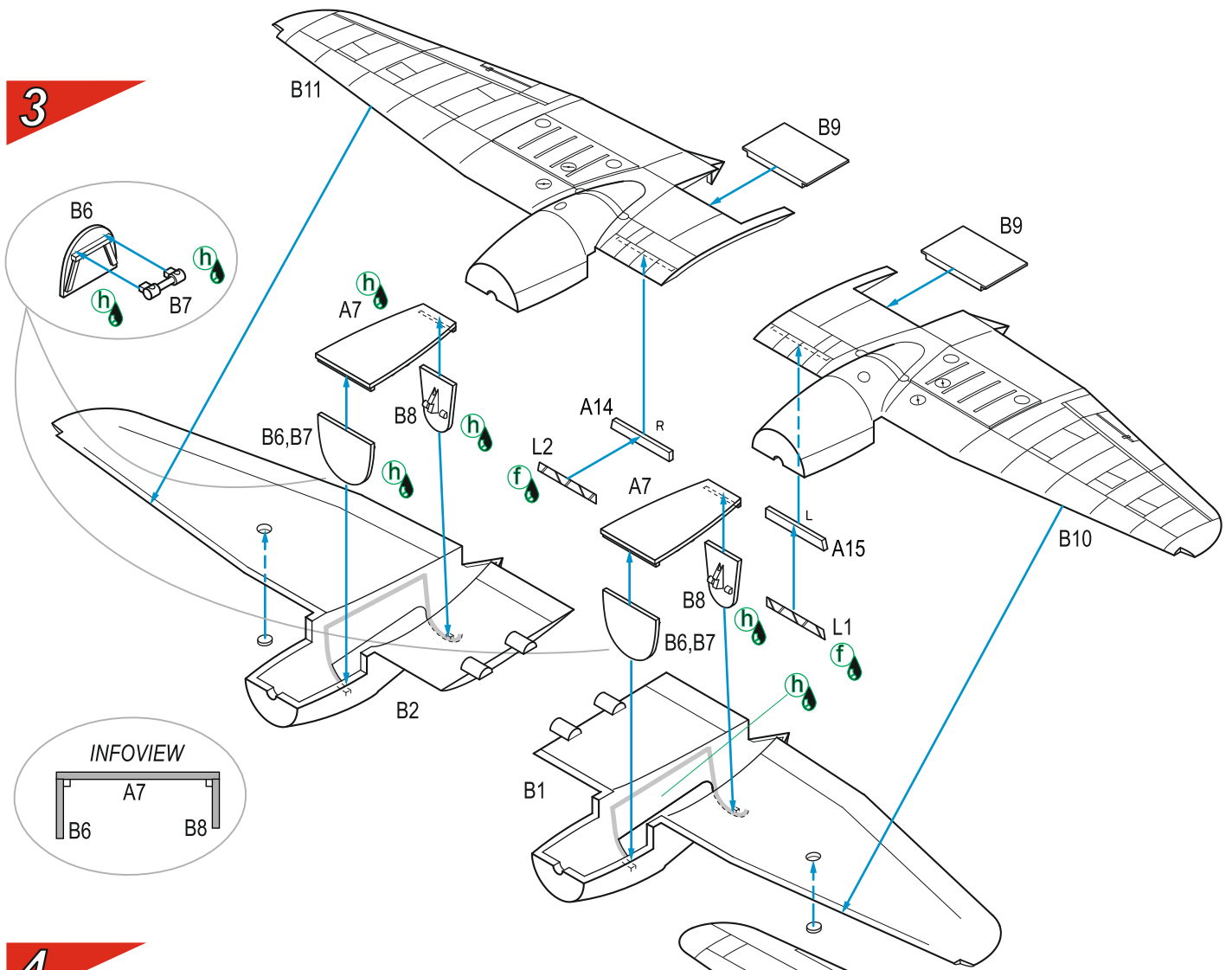

4

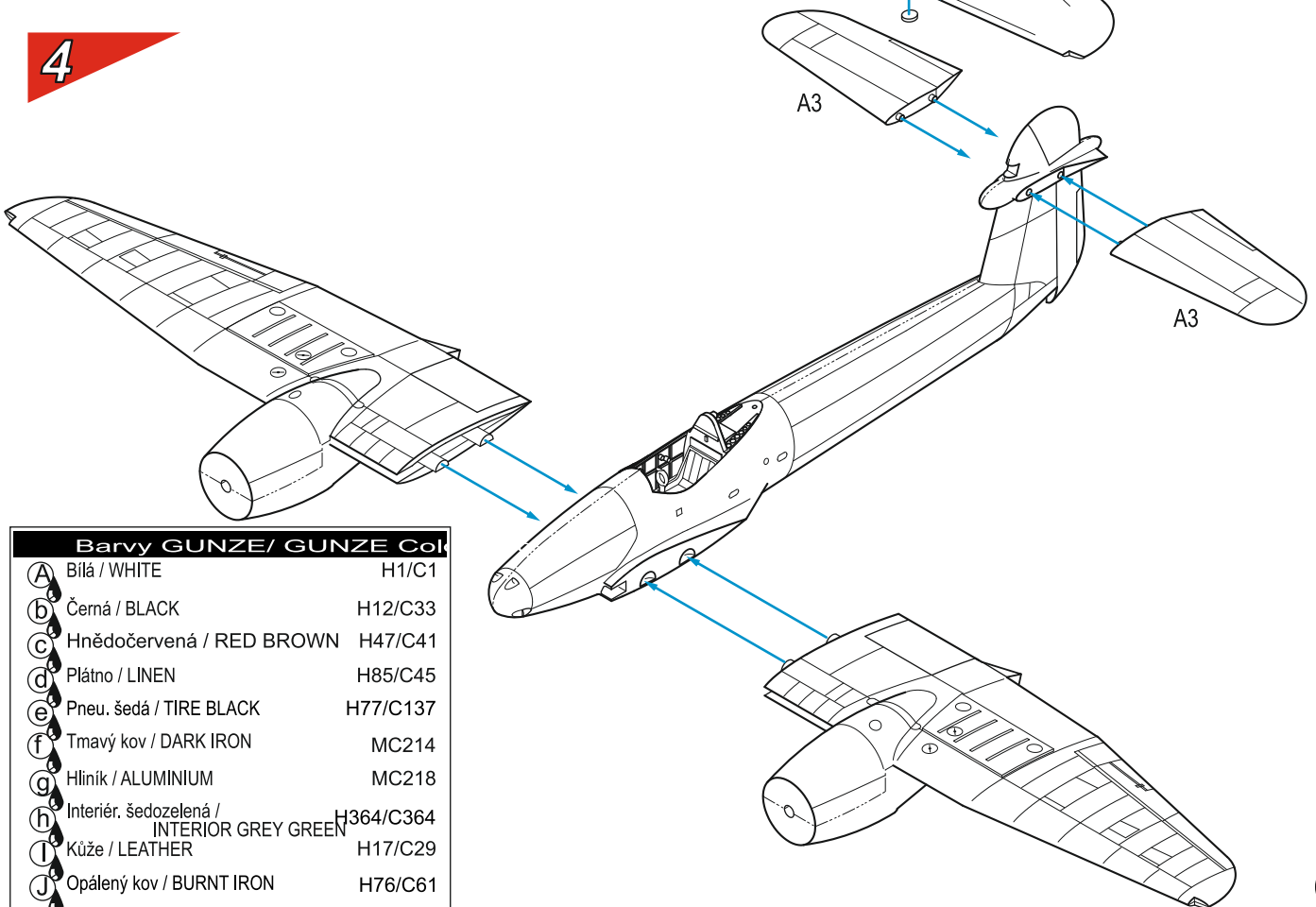

Barvy GUNZE/ GUNZE Col		
(A)	Bílá / WHITE	H1/C1
(b)	Černá / BLACK	H12/C33
(c)	Hnědočervená / RED BROWN	H47/C41
(d)	Plátno / LINEN	H85/C45
(e)	Pneu. šedá / TIRE BLACK	H77/C137
(f)	Tmavý kov / DARK IRON	MC214
(g)	Hliník / ALUMINIUM	MC218
(h)	Interiér, šedozeleňá / INTERIOR GREY GREEN	H364/C364
(l)	Kůže / LEATHER	H17/C29
(j)	Opálený kov / BURNT IRON	H76/C61

4

7

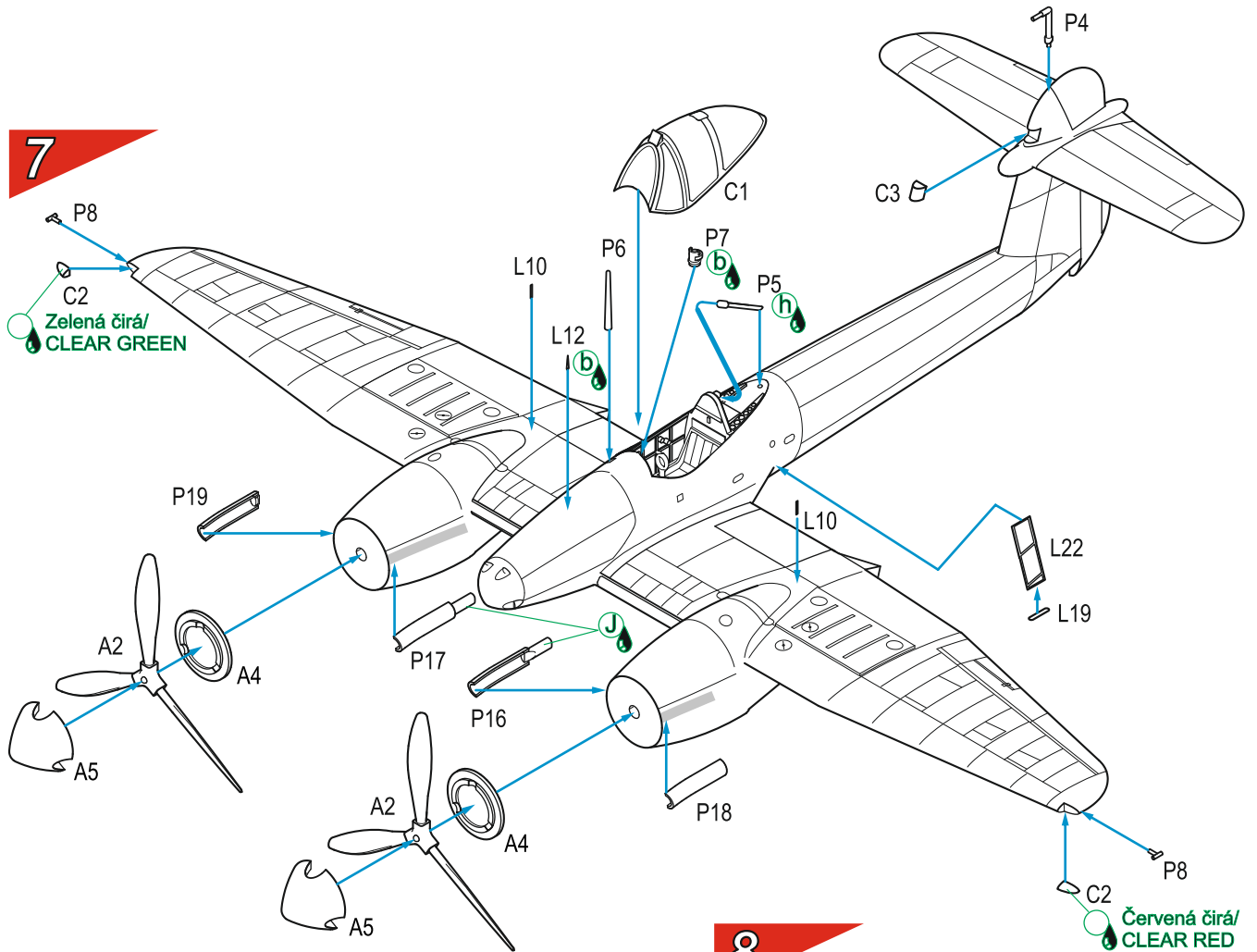

Pre-cut mask set M72052 (sold separately) is a great help in painting the canopy frames and undercarriage wheels tyres. Get yours, too!

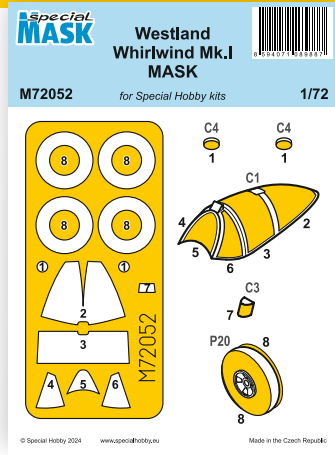

8

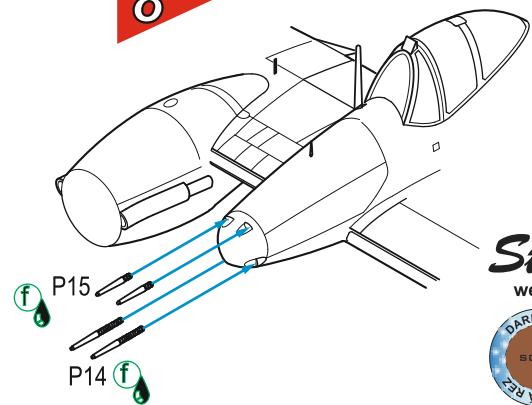

Star Dust weathering pigments

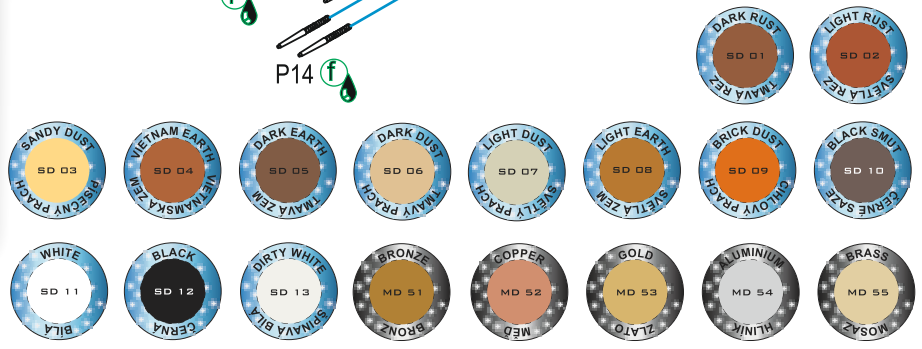

Use this!

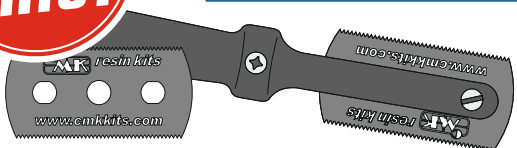

The Razor Saw with Handle (cat. n. H1010) is a great tool for cutting both plastic and resin. CMK also offers a wide variety of coarse/medium/fine saws.

**H1000** Ultra smooth and extra smooth saw (2 sides – 70 teeth / 42 teeth) 1 pc

**H1001** Ultra smooth saw (both sides – 70 teeth / 70 teeth) 1 pc

**H1002** Very smooth saw (both sides – 42 teeth / 42 teeth) 1 pc

**H1003** Smooth saw (both sides – 31 teeth / 31 teeth) 1 pc

**H1004** Ultra smooth and extra smooth saw (2 sides – 70 teeth / 42 teeth) 5 pcs

**H1005** Ultra smooth saw (both sides – 70 teeth / 70 teeth) 5 pcs

**H1006** Very smooth saw (both sides – 42 teeth / 42 teeth) 5 pcs

**H1007** Smooth saw (both sides – 31 teeth / 31 teeth) 5 pcs

**H1010** Razor Saw with Handle

5

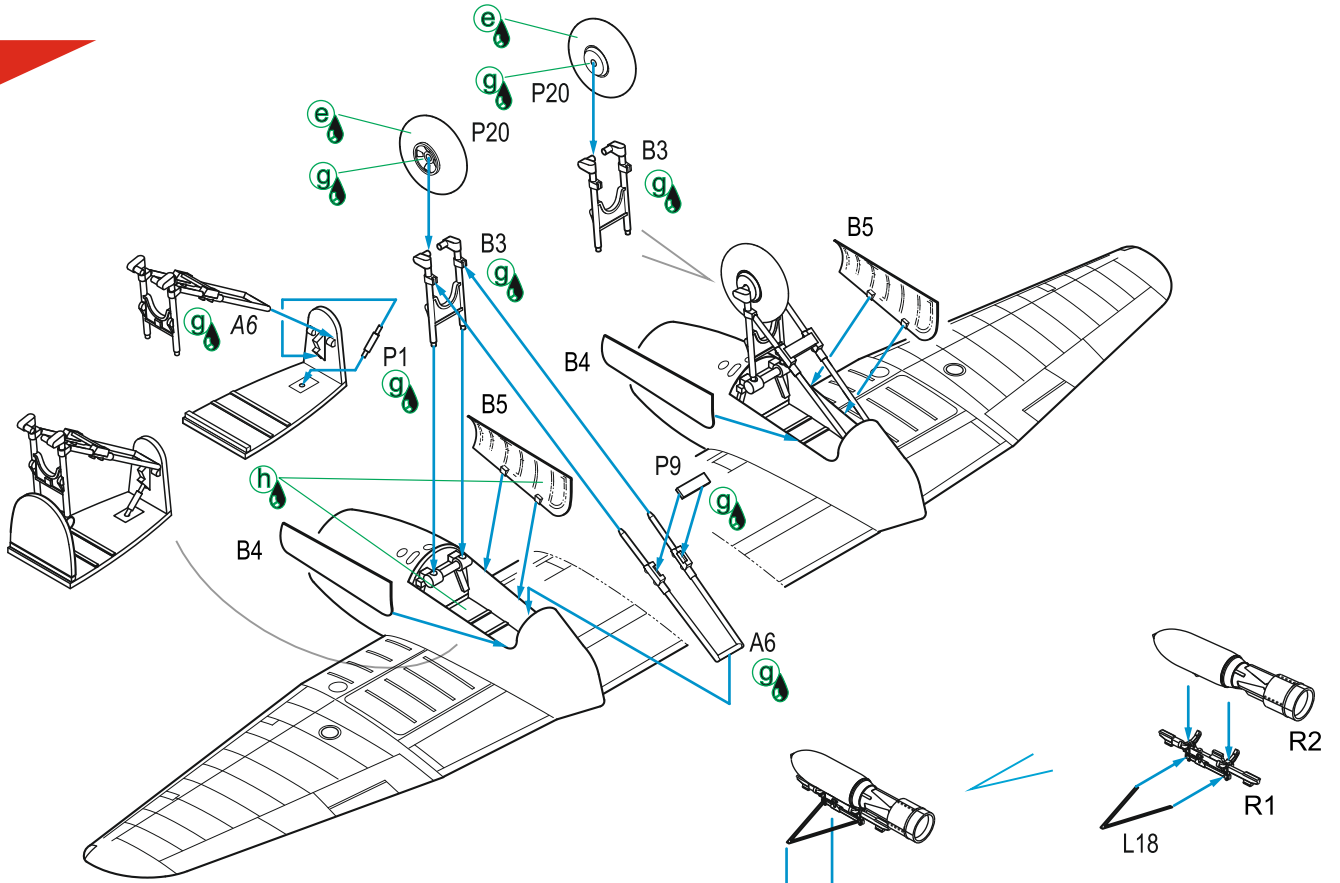

6

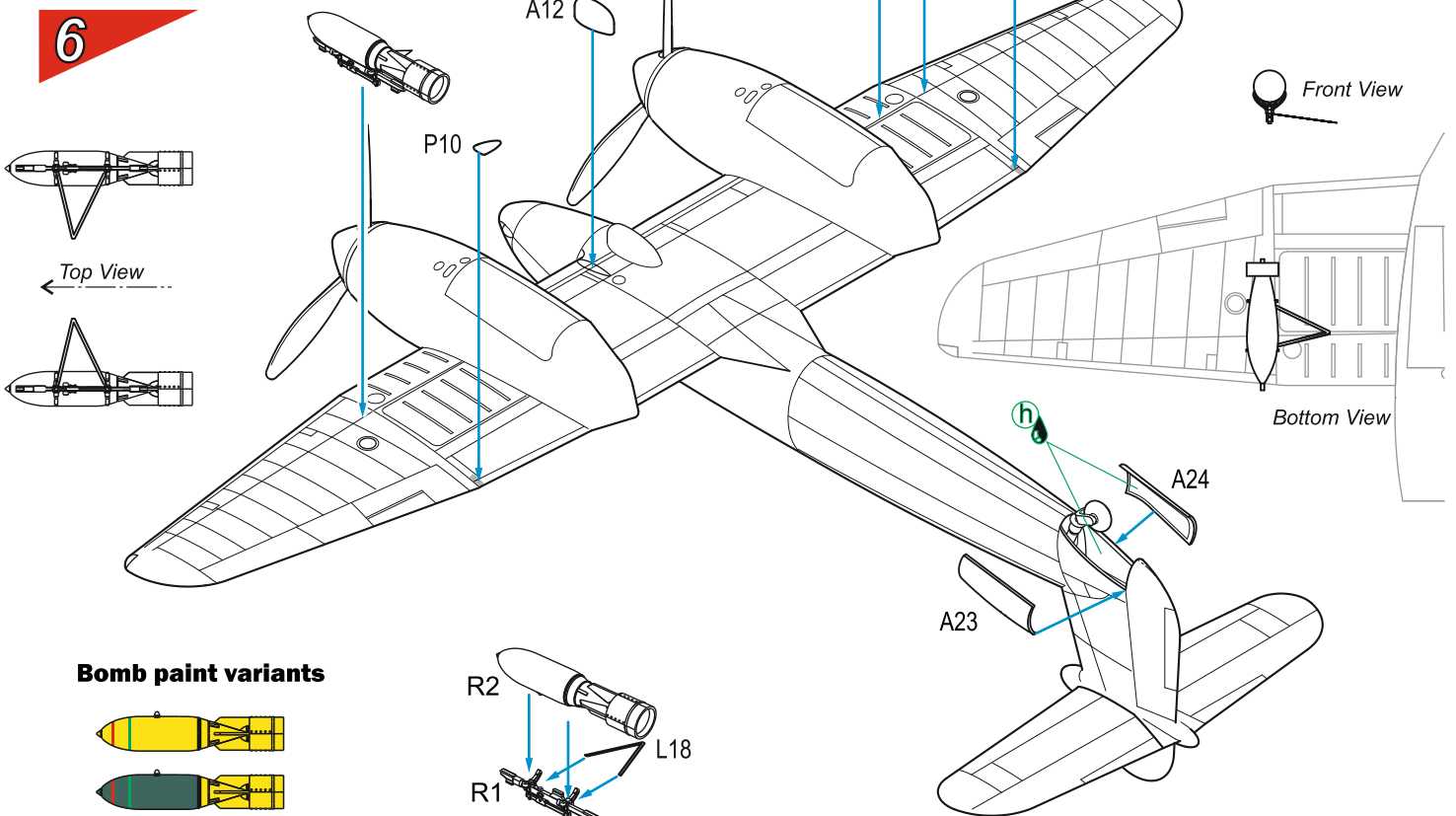

**Bomb paint variants**

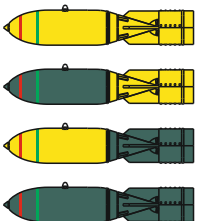

Westland Whirlwind FB Mk.I, P7094, HE-T, "Bellows", No.263 Squadron RAF, Warmwell airfield, beginning of 1943. Except the presentation writing below the canopy there's a pilot's name F/Lt Blackshaw on the port side in the brown rectangle of the original Dark Earth color. Canadian pilot F/O J. P. Coyne was photographed in the cockpit of this machine. The upper surface camouflage consists of three colors. Except of the Dark Green and Mixed Grey also Ocean Grey was used. The propeller spinners sport miniaturized national insignias. It is highly probable that this machine on March 28, 1943 participated in Roadstead 60 mission the attack on German convoy in La Manche channel. During this mission the Whirlbombers were escorted by Spitfires from No.310 (Czechoslovak) and No. 313 (Czechoslovak) RAF Squadrons. The aircraft was destroyed on May 16, 1943 with 166 hours of flight time assigned subsequently to No. 263, No. 137 and back with No. 263 RAF Squadrons.

Westland Whirlwind FB Mk.I, P7094, HE-T, „Bellows“, No.263 Squadron RAF, letiště Warmwell, začátek roku 1943. Kromě nápisu pod kabinou je na levé straně uvedeno jméno pilota F/Lt Blackshaw v hnědém obdélníku původní kamuflážní barvy Dark Earth. V kabině tohoto letounu se ale nechal fotit kanadský pilot F/O J. P. Coyne. Kamufláž horních ploch se skládá ze tří barev, kromě Dark Green a Mixed Grey ještě z Ocean Grey. Vrtulové kužely jsou ozdobeny miniaturami znaků. Stroj se s velkou pravděpodobností 28.3.43 zúčastnil akce Roadstead 60, útoku na německý konvoj v kanálu La Manche. Při této akci byly „Whirlbombery“ doprovázeny Spitfiry od No.310 (Českoslovak) a 313. (Českoslovak) Squadron RAF. Letoun byl zničen 16. května 1943 po nalétaných 166 hodinách, kterých dosáhl postupně u No.263, No. 137 a opět u No. 263 Squadron RAF.

## Camo A

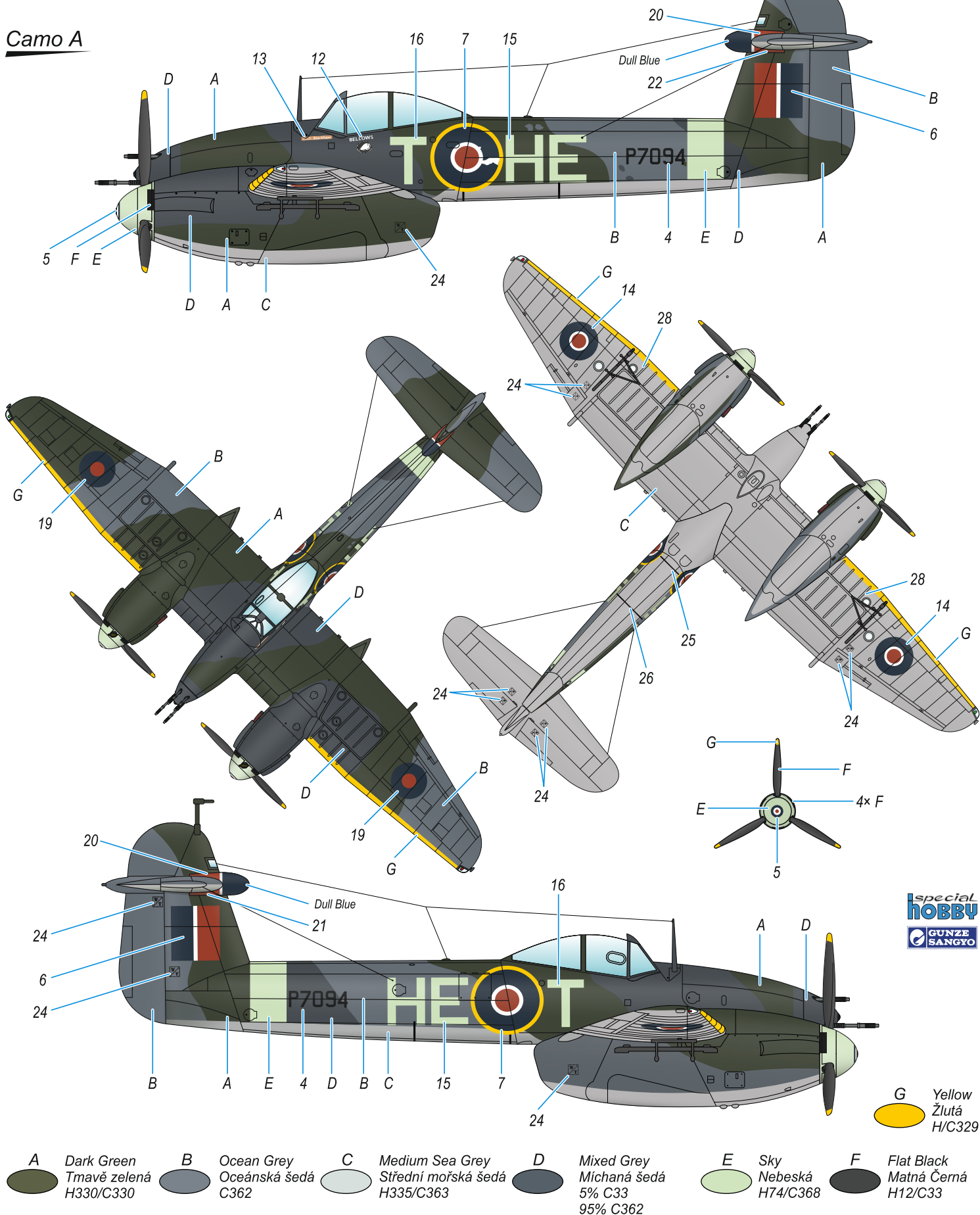

Westland Whirlwind FB Mk.I, P6974, HE-M, No.263 Squadron RAF, Angle airfield, July or August 1942. The aircraft wore Day Fighter Camouflage with black color on lower side of the wings and white stripes above and below the wings and whole nose section in white color, too. This ID was supposed for Dieppe operation but it can also be connected to Starkey operation or Rutter training. It served with No. 263 RAF Squadron from September 1940 to September 19, 1943 when it was lost in action. On 28 March 1942 this machine was flown from RAF Colerme to RAF Dumfries by Czechoslovak pilot S/O Cyril Novacek, a pilot with three victories over France. S/O Novacek had been hit and injured by friendly (French) anti aircraft fire on 10 June 1940, lost part of his right foot, and since then was excluded from further combat flying, even after his evacuation to the UK.

Westland Whirlwind FB Mk.I, P6974, HE-M, No.263 Squadron RAF, letiště Angle, červen nebo srpen 1942. Stroj v denní stíhací kamufláži je atypický černou barvou na spodní ploše křídla s bílými pruhy a bílou přídílí. V této podobě měl účastnit bojů nad Dieppe. Je však možné, že toto zbarvení souvisí s operací Starkey nebo cvičením Rutter. U No.263 Sq RAF létal od září 1940 až do 19. září 1943, kdy byl ztracen v akci. 28.3.1942 tento letoun přelétl S/O Cyril Nováček ze základny Colerme na letiště Dumfries. C. Nováček byl československý pilot, ve Francii dosáhl tří sestřelů. Vzhledem k tomu, že jej 10.6.1940 sestřelila a ranila vlastní (francouzská) protivzdušná obrana, přišel o část pravého chodidla a po evakuaci do Velké Británie nemohl bojově létat.

## Camo B

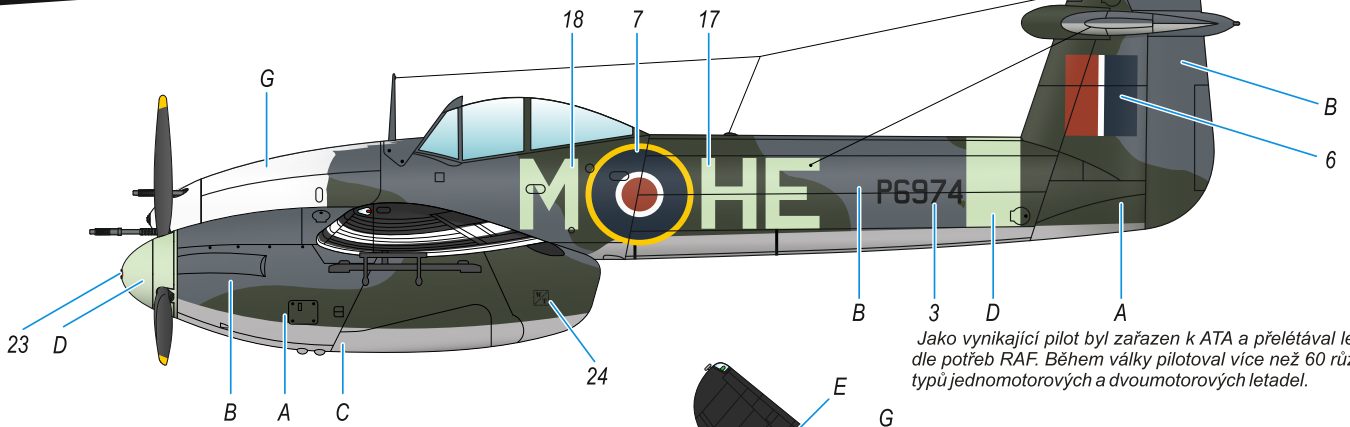

Jako vynikající pilot byl zařazen k ATA a přelétával letadla dle potřeb RAF. Během války pilotoval více než 60 různých typů jednomotorových a dvoumotorových letadel.

As he was clearly an excellent pilot, he found his new job with the ATA and transported various aircraft for the needs of the RAF. During the war, he accumulated flying experience on more than 60 various machines, both single and twin engine.

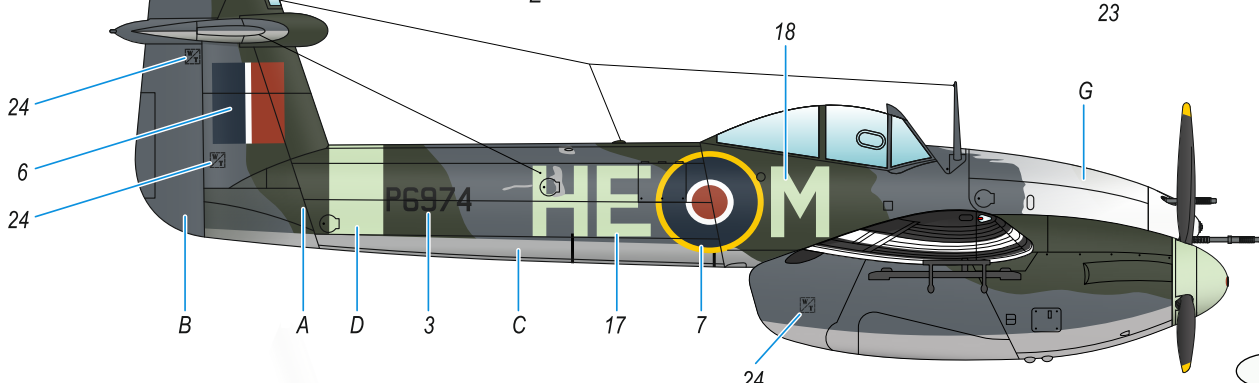
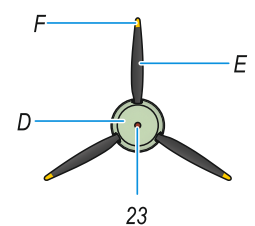
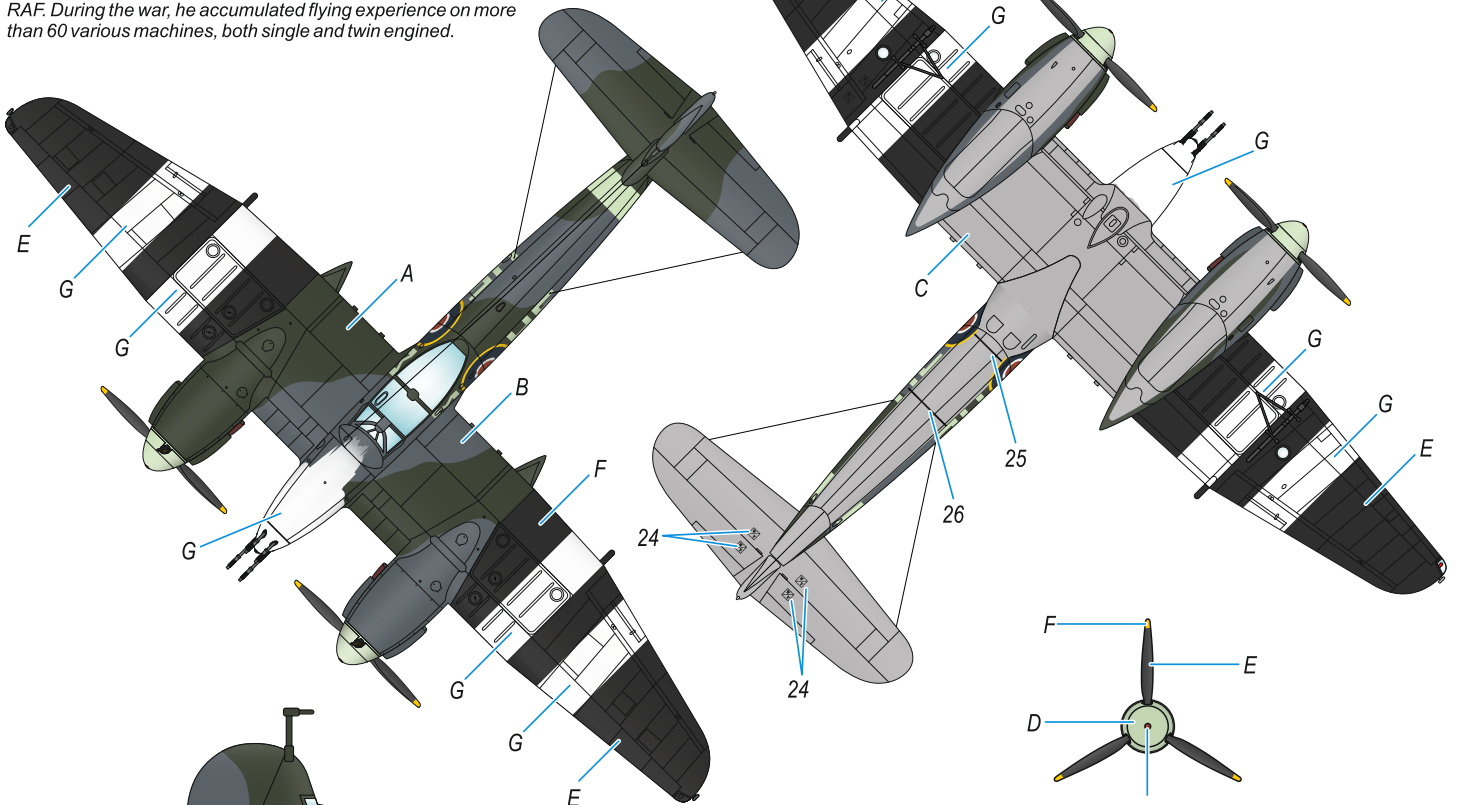

G Flat White  
Matná bílá  
H11/C62

- |   |   |  |  |   |  |
|---|---|--|--|---|--|
|  <b>A</b> Dark Green<br>Tmavě zelená<br>H330/C330 |  <b>B</b> Mixed Grey<br>Míchaná šedá<br>5% C33<br>95% C362 |  <b>C</b> Medium Sea Grey<br>Střední mořská šedá<br>H335/C363 |  <b>D</b> Sky<br>Nebeská<br>H74/C368 |  <b>E</b> Flat Black<br>Matná Černá<br>H12/C33 |  <b>F</b> Yellow<br>Žlutá<br>H/C329 |
|---|---|--|--|---|--|



Westland Whirlwind FB Mk.I, P7102, SF-P, „Comrades In Arms“, P/O E.L. Musgrave, No.137 Squadron RAF. The upper surfaces' camouflage consisted of standard Dark Green and makeshift Mixed Grey. The inscription „Comrades in Arms“ was written on the port board below the canopy. This machine served with No.137 Squadron RAF from June 1942 to September 1943, when it was handed over to No. 263 Squadron RAF. In September 1944 was this machine withdrawn from service and subsequently scrapped.

Westland Whirlwind FB Mk.I, P7102, SF-P, „Comrades In Arms“, P/O E. L. Musgrave, No.137 Squadron RAF. Na horních plochách nesl tento stroj mimo standardní Dark Green náhražkovou Mixed Grey. Jméno Comrades In Arms bylo napsáno na levém boku pod kabinou. U No.137 Squadron RAF sloužil tento stroj od června 1942 do září 1943. Pak byl předán No.263 Squadron RAF. Vyřazen a sešrotován byl v září 1944.

### Camo C

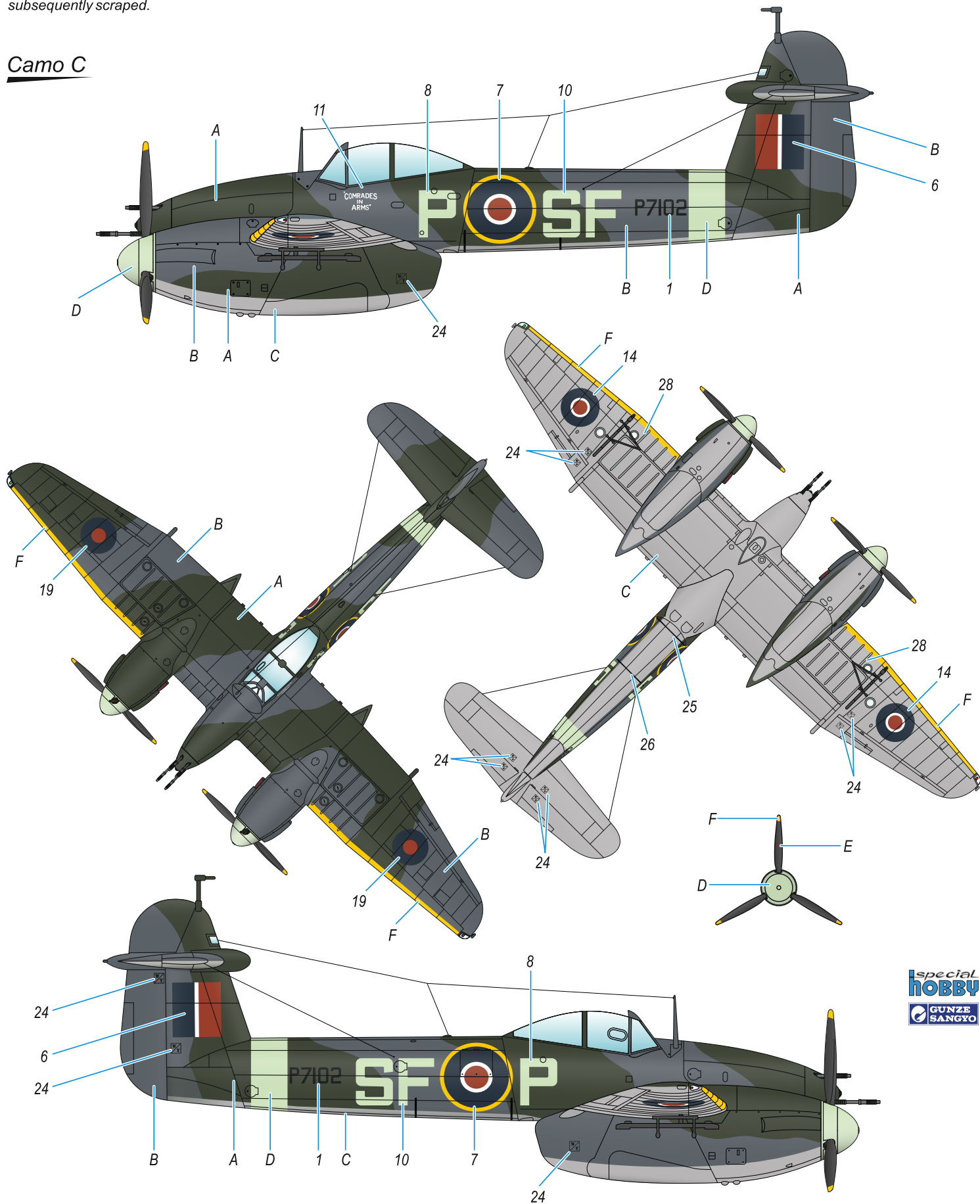

- |  |   |  |                                     |   |                                    |
|--|---|--|-------------------------------------|---|------------------------------------|
| <b>A</b> Dark Green<br>Tmavě zelená<br>H330/C330 | <b>B</b> Mixed Grey<br>Míchaná šedá<br>5% C33<br>95% C362 | <b>C</b> Medium Sea Grey<br>Střední mořská šedá<br>H335/C363 | <b>D</b> Sky<br>Nebeská<br>H74/C368 | <b>F</b> Flat Black<br>Matná Černá<br>H12/C33 | <b>F</b> Yellow<br>Žlutá<br>H/C329 |
|--|---|--|-------------------------------------|---|------------------------------------|

Westland Whirlwind FB Mk.I, P7012, SF-V, No.137 Squadron RAF. The upper surfaces' camouflage consisted of standard Dark Green and makeshift Mixed Grey. This machine served with No.137 Squadron RAF from November 1941 to June 1943, when it was handed over to No. 263 Squadron RAF. In July 1944 was this machine withdrawn from service and subsequently scrapped.

Westland Whirlwind FB Mk.I, P7012, SF-V, No.137 Squadron RAF. Na horních plochách nesl tento stroj mimo standardní Dark Green náhražkovou Mixed Grey. No.137 Squadron RAF používala tento stroj od listopadu 1941 do června 1943. Pak ho předala No.263 Squadron RAF. Vyřazen a zlikvidován byl v červenci 1944.

### Camo D

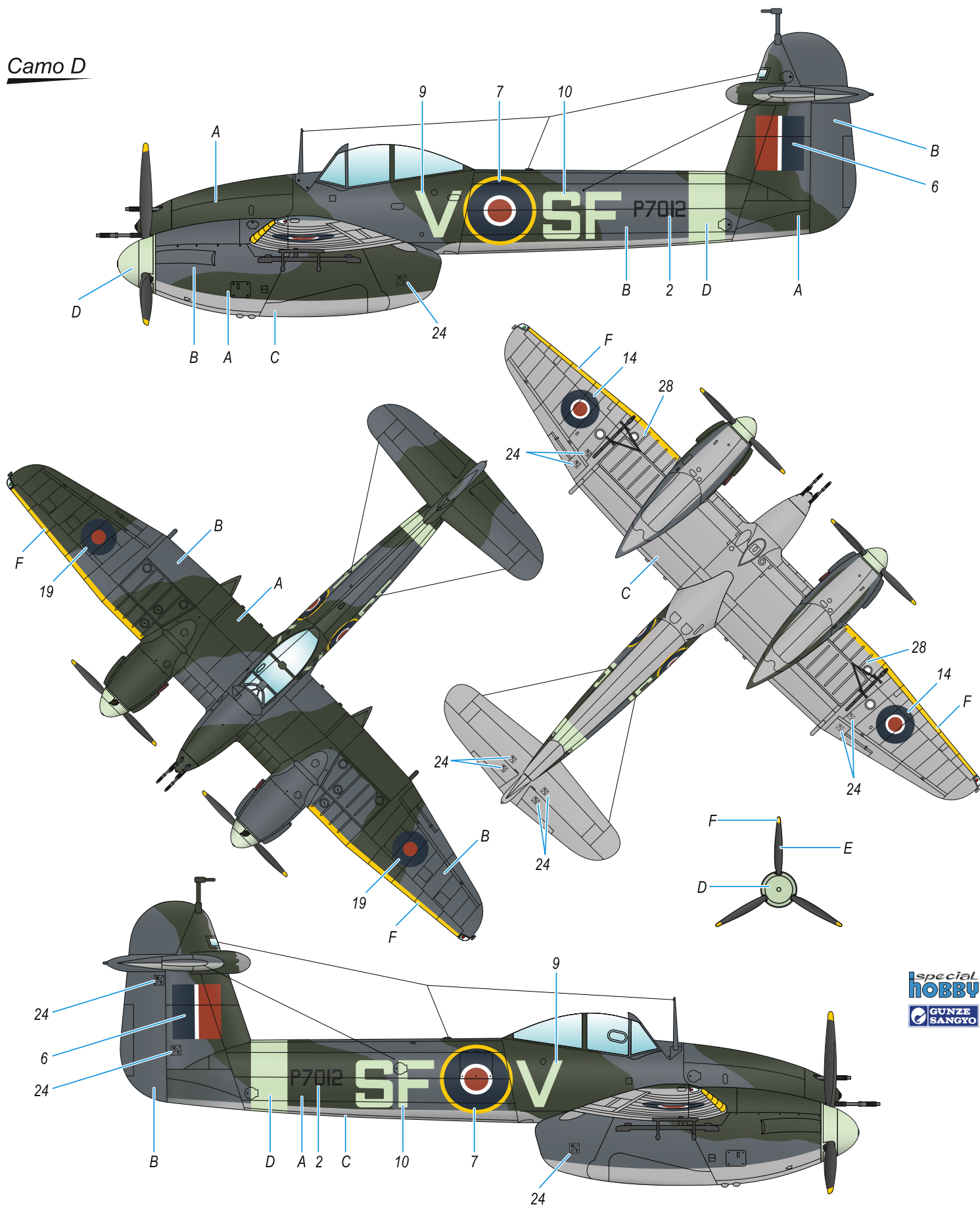

special  
HOBBY  
GUNZE  
SANGYO

- |  |   |  |                                     |   |                                    |
|--|---|--|-------------------------------------|---|------------------------------------|
| <b>A</b> Dark Green<br>Tmavě zelená<br>H330/C330 | <b>B</b> Mixed Grey<br>Míchaná šedá<br>5% C33<br>95% C362 | <b>C</b> Medium Sea Grey<br>Střední mořská šedá<br>H335/C363 | <b>D</b> Sky<br>Nebeská<br>H74/C368 | <b>F</b> Flat Black<br>Matná Černá<br>H12/C33 | <b>F</b> Yellow<br>Žlutá<br>H/C329 |
|--|---|--|-------------------------------------|---|------------------------------------|

**In the line of 3D printed sets, Special Hobby offers excellent detail and correction sets for the 1/72 Airfix kits **Hawker Tempest Mk.V** and **Hawker Typhoon Mk.I**. For both kits, we also offer 3D printed pilot and mechanic figures with accumulator trolley and detailed cast main wheels.**

F72402 Tempest Pilot, Dog and Mechanic with Accumulator Trolley

P72008 Tempest Mk.V Engine and Fuselage Tanks

P72009 Tempest Mk.V Early Gun Barrels

P72010 Tempest Mk.V Gun Sight and Seat Correction Set

P72011 Tempest Mk.V Exhausts

P72012 Typhoon Mk.I Engine

P72013 Typhoon Mk.I Gun Sight and Seat Correction Set

P72014 Typhoon Mk.I Three-blade Propeler

P72015 Typhoon Mk.I Gun Bays Correction Set

P72016 Typhoon Mk.I Standard Exhausts

P72021 Tempest Bombs (1000 Lb) and racks

Q72413 Tempest/Typhoon Early type Wheels

Q72414 Tempest Late Type Wheels



Tempest

Note:  
P72XXX - 3D printed sets  
Q72XXX - resin cast set  
(printed master)

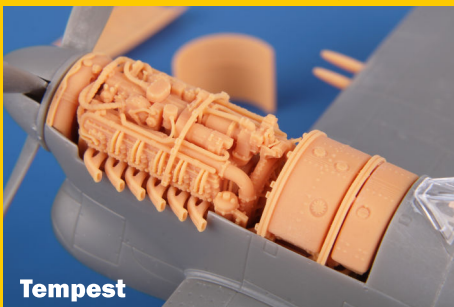

Tempest

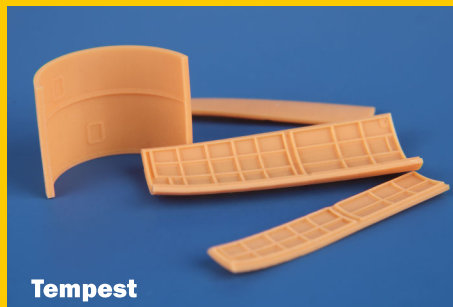

Tempest



Tempest

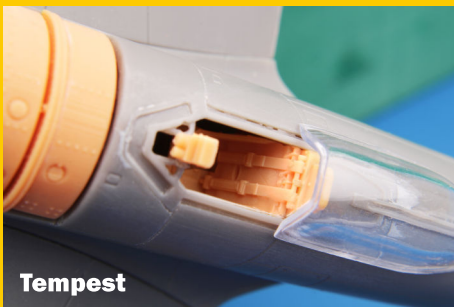

Tempest

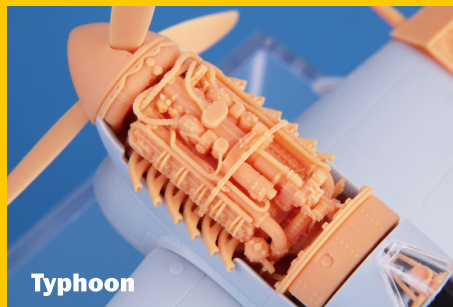

Typhoon



Typhoon



Typhoon

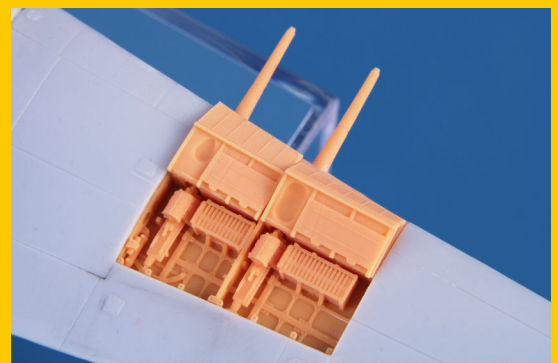

Tempest



Tempest

Special  
**HOBBY**  
SH72475



**Heinkel He 162A Spatz 'Captured Birds' 1/72**

**SH72453**



**DH.100 Vampire Mk.3**

**'European and American Operators' 1/72**



**SH72251**

**Digby Mk.I 1/72**



**SH72251**

**Delta 1D/E US Transport plane**

Special  
**HOBBY**



facebook.com/specialhobby | [WWW.SPECIALHOBBY.EU](http://WWW.SPECIALHOBBY.EU) | [WWW.CMKKITS.COM](http://WWW.CMKKITS.COM)

