

Yakovlev Yak-3 "Normandie-Niemen"

Historie

CZ

Po napadení Sovětského svazu Německem se brzy ukázalo, že sovětské stíhačky zaostávají za německými. Útok přišel v době, kdy byly do výroby a výzbroje zaváděny nové stroje typů Jak-1, Lagg-3 a Mig-3. S výjimkou výškového Mig-3 ani jeden typ nedosahoval kvalit německých stíhaček. Sovětští konstruktéři zápasili s problémy nedostatku kvalitních surovin, vybavení, nekvalitní výroby, nedostatečně výkonnými motory a v neposlední řadě i "odbornými" direktivami komunistického vedení země. Jakovlevova konstrukční kancelář postupně vyvíjela na základě Jaku-1 další varianty dle požadavků VVS (Vojenské vzdušné síly SSSR). Ale všechny verze Jaků-7, následníků Jaku-1 nepřekonávaly výkonově německé stíhače. V roce 1942 byla poprvé v boji použita nová stíhačka Jak-9. Ta byla vyvíjena na základě Jaku-7, tvořila tzv. těžkou vývojovou větev stíhaček Jak. Zároveň byla od roku 1941 vyvíjena nová lehká, proti Jaku-7 zmenšená, odlehčená a obratná stíhačka smíšené konstrukce. Ta dostala nové křídlo se zmenšeným rozpětím a olejovými chladiči přesunutými do jeho kořenů. Označena byla Jak-3. Tvořila lehkou větev stíhaček Jak. Označení Jak-3 již sice jednou Jakovlev použil. Nesla ho těžce vyzbrojená stíhačka postavená v roce 1940, která ale zůstala v prototypu. Druhý Jak-3 to z počátku také neměl snadné. Vývoj byl obtížný a státní zkoušky byly ukončeny až v říjnu 1943. Nové Jaky dostaly motor Klimov M-105PF-2. Díky nekvalitní výrobě byla u prvních Jaků-3 překročena prázdná váha proti zkušebnímu strojímu a proto prvních 197 kusů neslo výzbroj kanonu ráže 20 mm v ose vrtule a jednoho kulometu ráže 12,7 mm na trupu. Další sériové stroje používaly výzbroj kanonu ráže 20 mm v ose vrtule a dvou kulometů ráže 12,7 mm na trupu. Do výzbroje byly nové Jaky zavedeny až v roce 1944. Dostávaly je nejlepší sovětské jednotky a na tento typ byla přezbrojena také slavná francouzská dobrovolnická stíhací jednotka Normandie-Němen. Ta se na svých Jacích vrátila v červnu 1945 do Francie. Normandie-Němen používala Jaky-3 i po válce. Kromě sovětského a francouzského letectva zařadilo Jaky-3 do výzbroje po válce letectvo Polska a Jugoslávie.

Jak-3 byl dále vyvíjen, ale vše selhávalo na vývoji vhodného motoru. Až po válce byla vyrobena malá serie verze Jak-3M-107 s motorem Klimov M-107 a celokovovou konstrukcí a potahem. Další verze, jako Jak-3 RD s raketovým motorem v zádi trupu či Jak-3M-108 nebo Jak-3U zůstaly v prototypu. Jak-3 je považován za jeden z nejlepších stíhacích letounů druhé světové války a nejlepší stíhací letoun východní fronty.

Rozpětí: 9,20 m, délka: 8,49 m, max. rychlost: 655 km/h ve výšce 3100 m, dolet 900 km, počáteční stoupavost 19,3 m/s.

History

EN

Following the German attack against the Soviet Union, it soon became clear that Soviet fighter aircraft lacked in performance against German aircraft. The German attack came during a period when new Soviet types were being introduced into production and service, types such as the Yak-1, Lagg-3 and Mig-3. Save for the Mig-3 high altitude plane, all the other types were rather inferior to German machines. Soviet designers struggled with shortage of high quality raw materials, insufficient equipment, poor-performing engines and last but not least with "expert" directives from the communist leaders of the country. The Yakovlev design bureau were developing new subtypes based on the Yak-1 fighter, trying to meet the VVS (Voyenno Vzdushnye Sily / Air Force) requirements. However, all versions that emerged from the Yak-1 development, designated as the Yak-7, were still lacking in performance compared with their German contemporaries. In 1942, a new fighter type known as the Yak-9 was introduced into service. This type, originating from the Yak-7 design, was the first of the Yak heavy fighters family. Since 1941, simultaneously, a new type was being developed, a nimble and light-weight type with smaller dimensions and of mixed construction. It utilised a new wing too, with shorter span and oil coolers moved into the root section. This type was later to be known as the Yak-3 and formed the light-weight family of Yak fighters. Of interest might be that the Yak-3 designation had already been used once by the Yakovlev bureau, but it belonged to a heavily armed fighter prototype built back in 1940 which, had not progressed beyond the prototype stage. The second type to be known as the Yak-3 also had it quite tough from the outset, and development was not easy, with the acceptance trials not completed until October 1943. The new Yaks were equipped with Klimov M-105PF-2 engines and because of poor production standards, the overall weight exceeded the limits given for test machines, which meant that the first 197 production aircraft were armed with only one 20mm cannon firing through the propeller shaft and one 12.7mm machine gun mounted in the forward fuselage above the engine. Further production machines received their full armament of one 20mm cannon and two 12.7mm machine guns. The new machines were not introduced into service until 1944, and the first units to receive them were the elite units of the VVS plus the French volunteer unit known as the Normandie Niemen regiment. This French unit made its return to France in June 1945 and the Yak-3 type remained with them for some time even after the war. Besides the Soviet and French air forces, the Yak fighter saw service also with the military of Poland and Yugoslavia.

The Yakovlev bureau tried to develop the type further, but with no great success because of lack of proper engine development. Only after the war, a small series of Yak-3M-107 planes were produced, this type being fitted with a Klimov M-107 engine and featuring an all-metal construction and metal skin. Yet another version appeared, the Yak-3RD with a rocket engine unit in the rear fuselage, or the Yak-3M-108 and Yak-3U, all of which progressed no further than prototype stage. The Yak-3 fighter is considered one of the best WWII fighter types and the very best to see action over the Eastern Front.

Wingspan: 9,20 m, Length: 8,49 m, Top Speed: 655 km/h at 3100 m, Range: 900 km, initial climbing: 19,3 m/s.

A

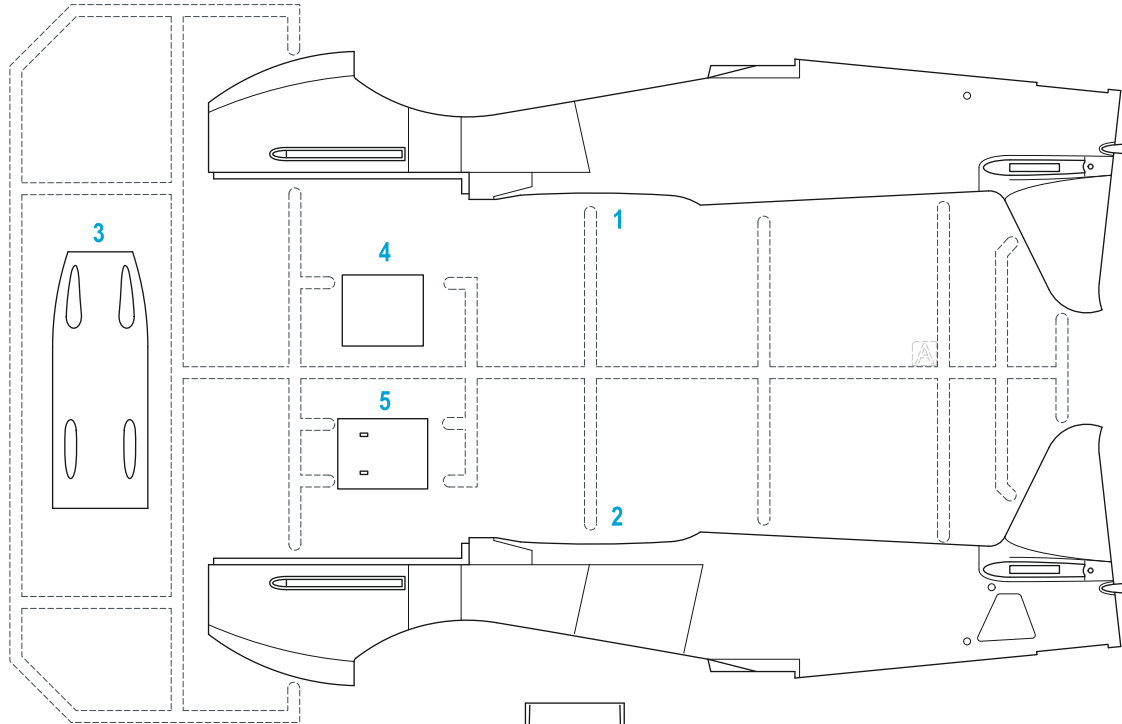

B

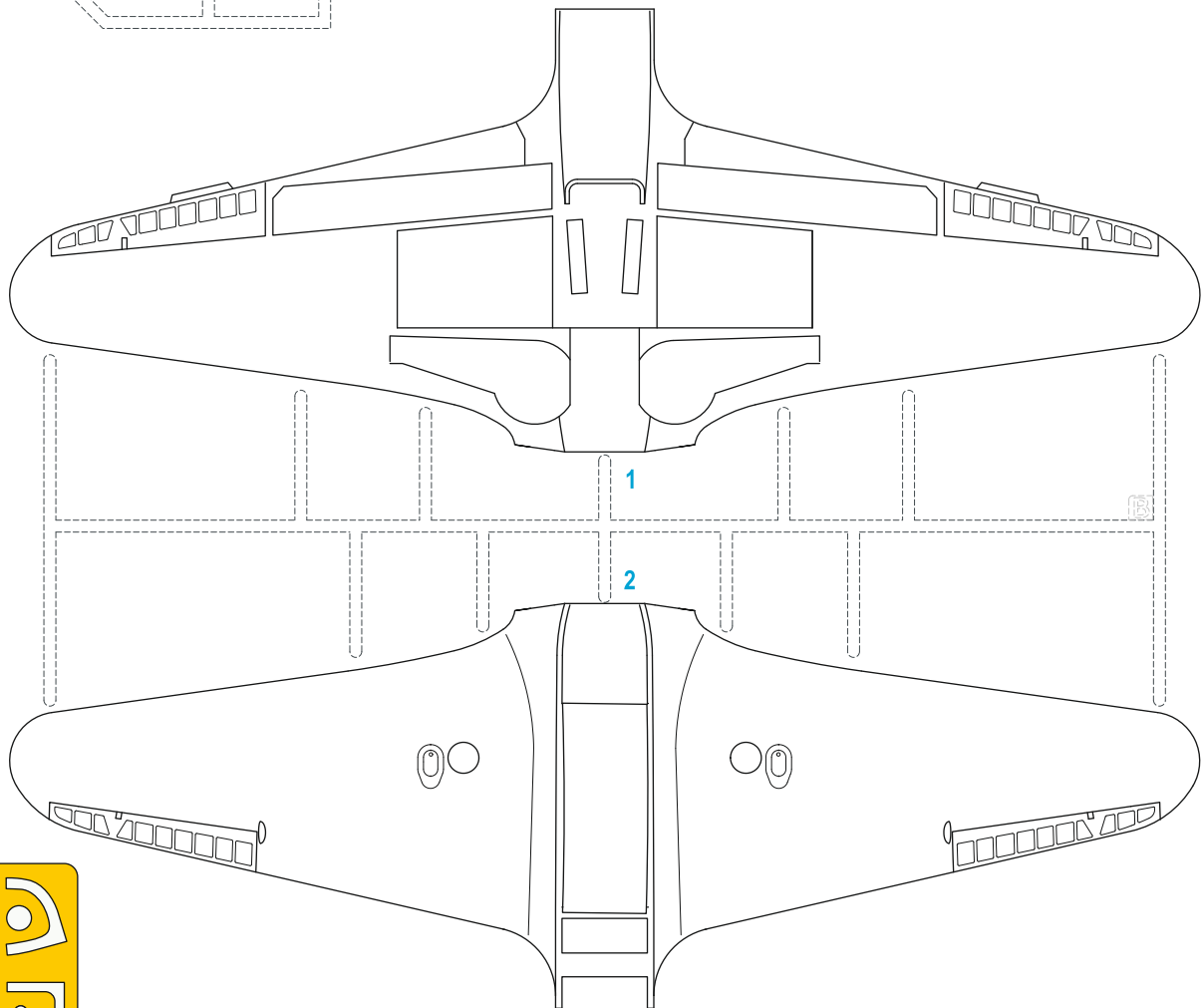

MASK

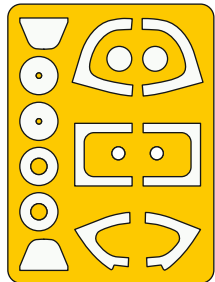

✗ Pozn.: nepoužité díly/ ✗
 Note: UNUSED PARTS

SYMBOLS



MOŽNOST VOLBY
 OPTIONAL
 NACH BELIEBEN
 OPTION



POUŽÍT KYANOAKRYLÁTOVÉ LEPIDLO
 INSTANT CYANOACRYLATE GLUE
 ZYANOAKRYLATKLEBER
 ADHÉSIF CYANOACRYLAT



OHNOUT
 BEND
 BIEGEN
 COURBER



ZHOTOVIT NOVÉ
 SCRATCH BUILD
 FERTIGSTELLEN
 ACHEVER



ŘEZAT/VRTAT
 CUT OFF/DRILL
 ENTFERNEN
 DETACHER



GSI
 colours code



NATRÍT
 COLOUR
 FARBEN
 PEINDRE

2

C

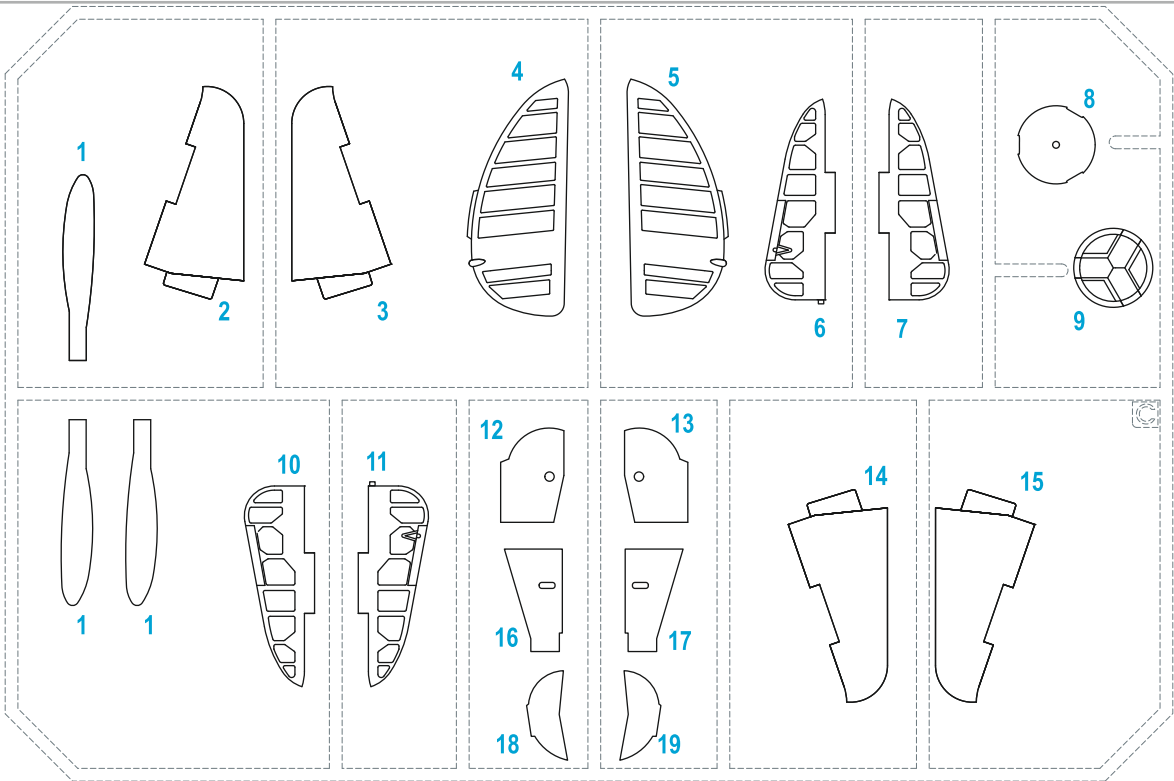

D

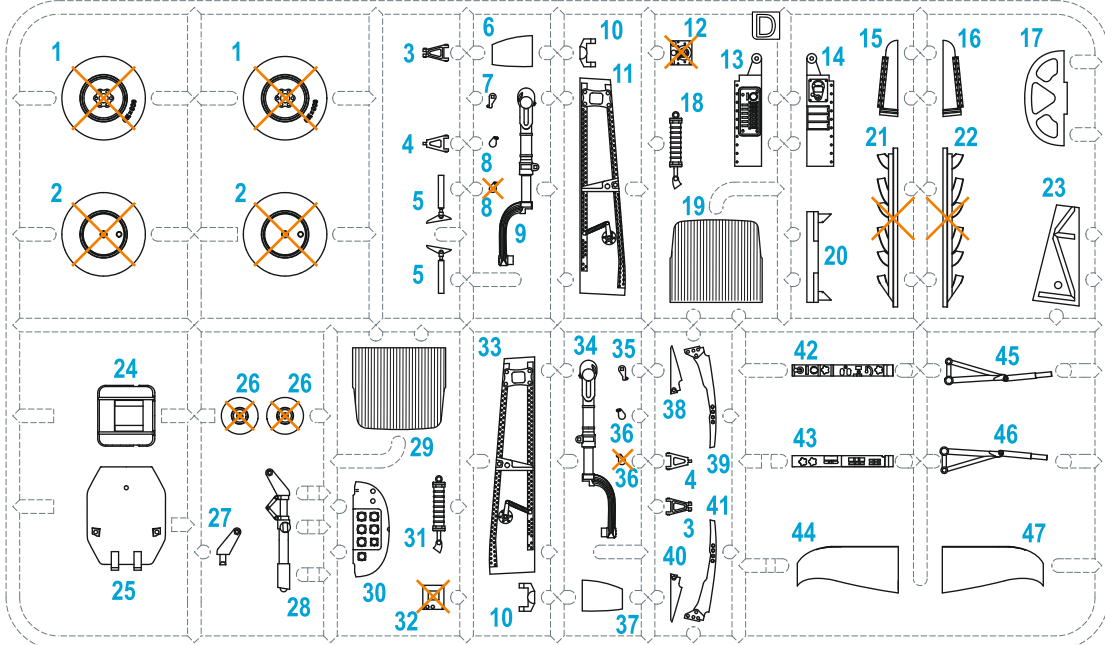

E

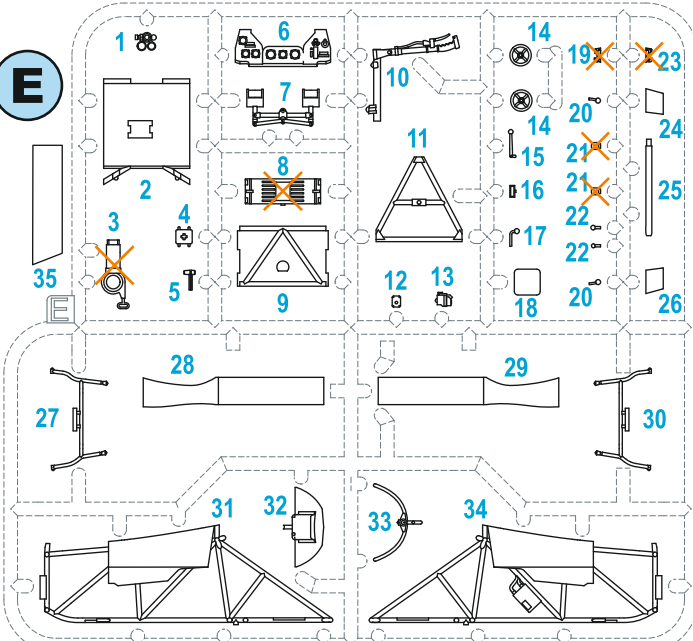

CP

CLEAR PARTS

PUR PARTS

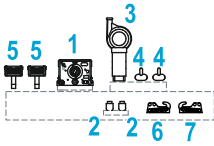
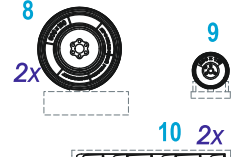
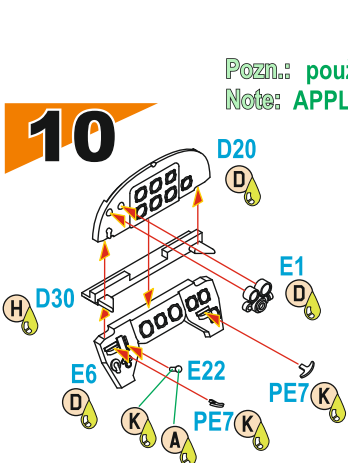
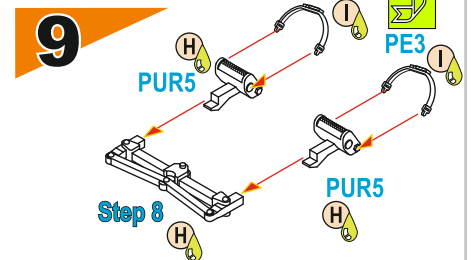
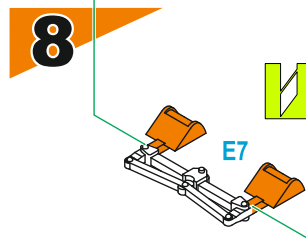
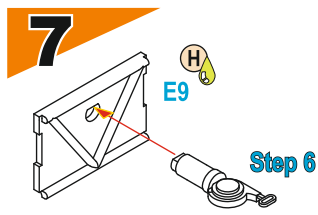
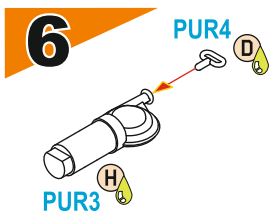
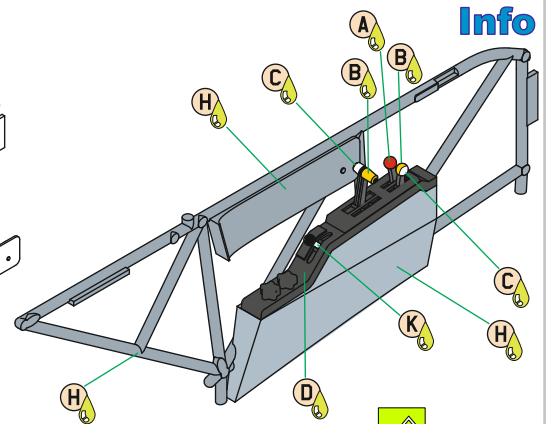
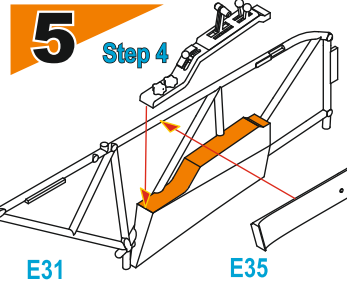
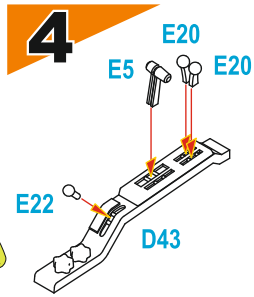
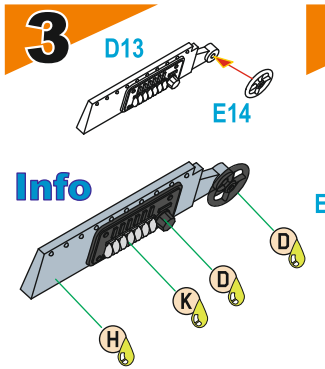
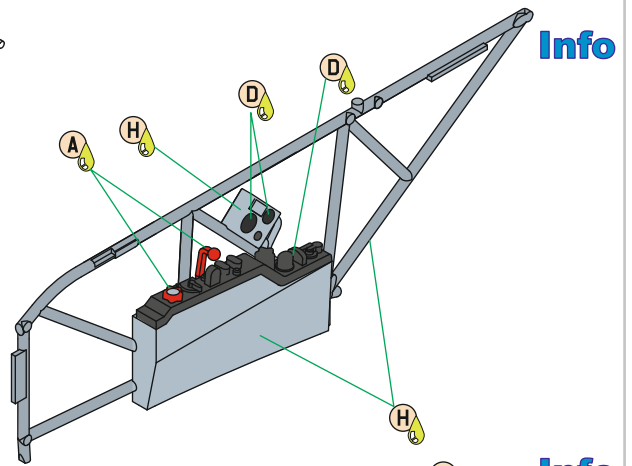
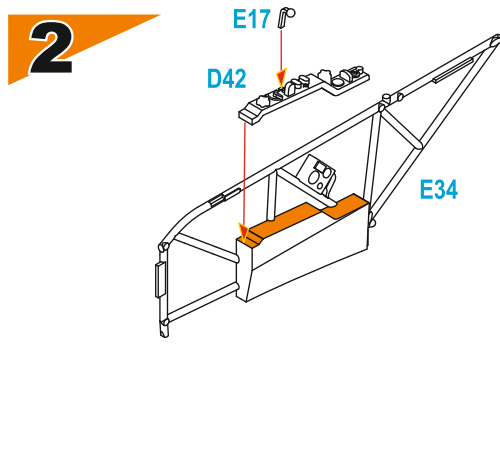
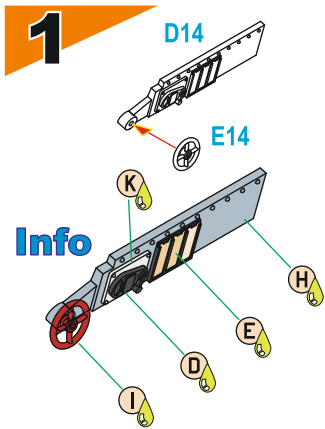
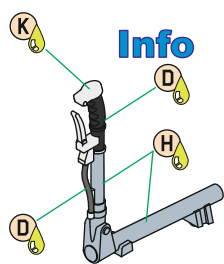
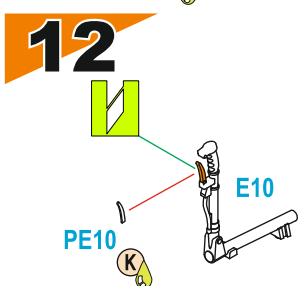
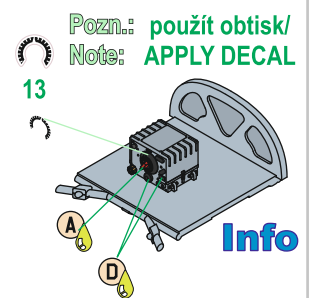
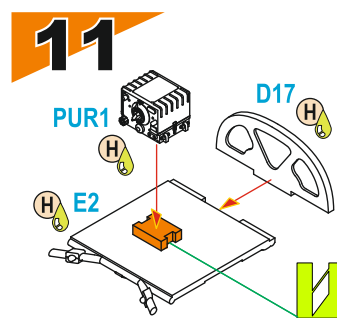
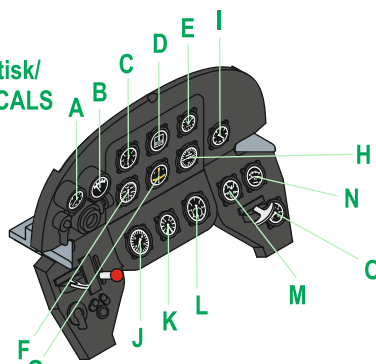

PHOTO-ETCHED PARTS





Pozn.: použít obtisk/
Note: APPLY DECALS



barvy/ colours



A	Červená/ RED	H3/C3
B	Žlutá/ YELLOW	H4/C4
C	Bílá/ WHITE	H11/C62
D	Černá/ BLACK	H12/C33
E	Žlutohnědá/ TAN	H27/C44
F	Opálený kov/ BURNT IRON	H76/C61
G	Černá na pneu./ TIRE BLACK	H77/C137
H	Světlá šedomodr/ LIGHT GULL GRAY	H51/C11
I	Červenohnědá/ RED BROWN	H47/C41
J	Tmavý kov/ DARK IRON	H28/C78
K	Hliník/ ALUMINIUM	H8/C8

13

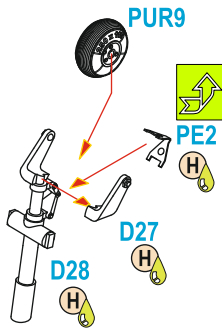

Info

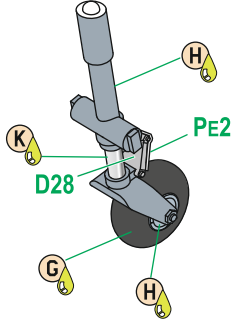

14

Info

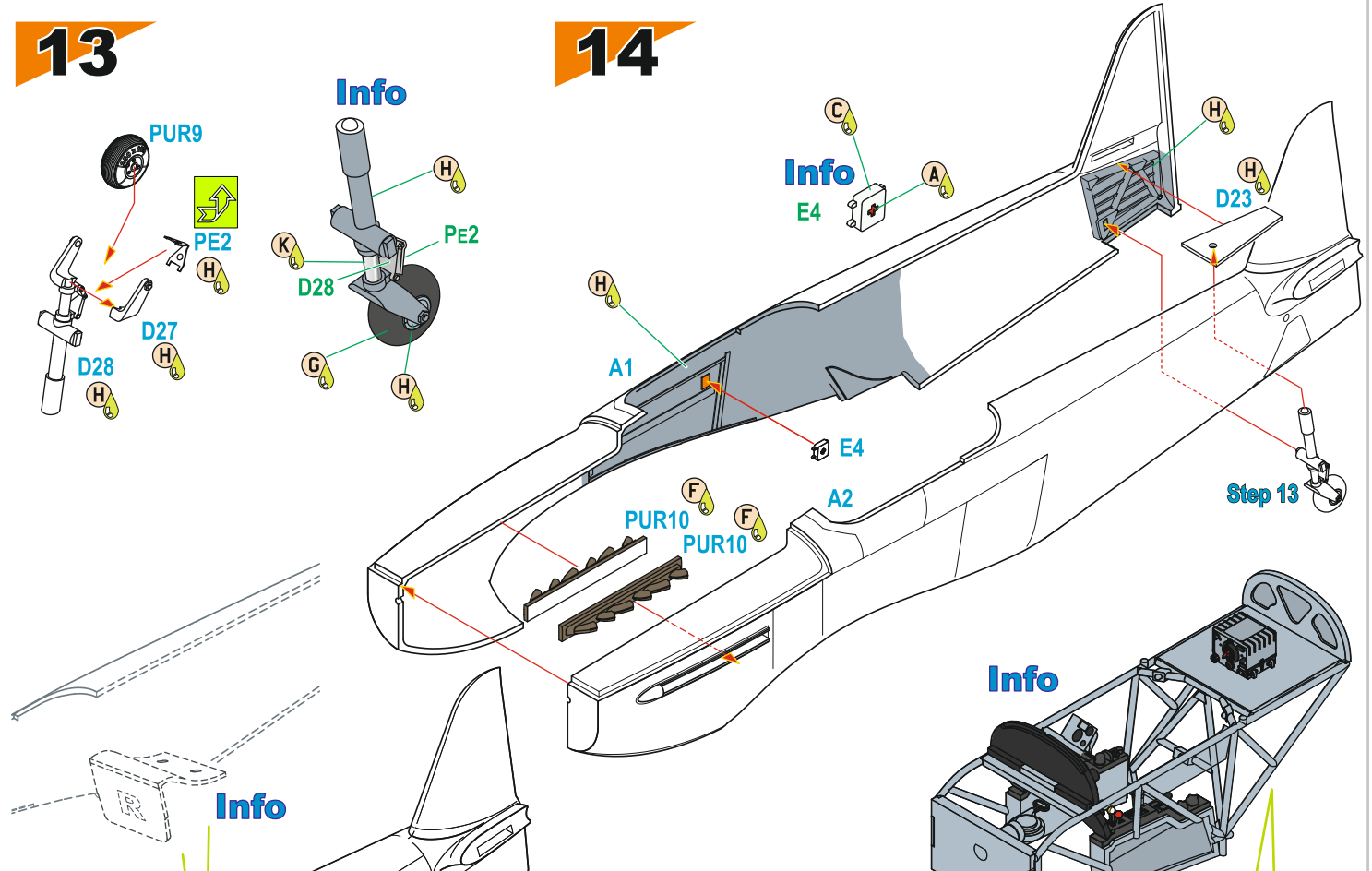
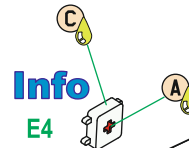

Step 13

Info

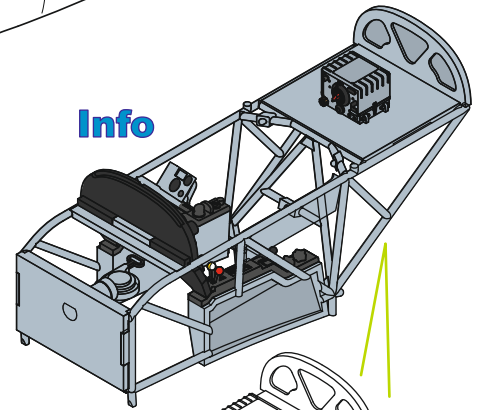

15

Info

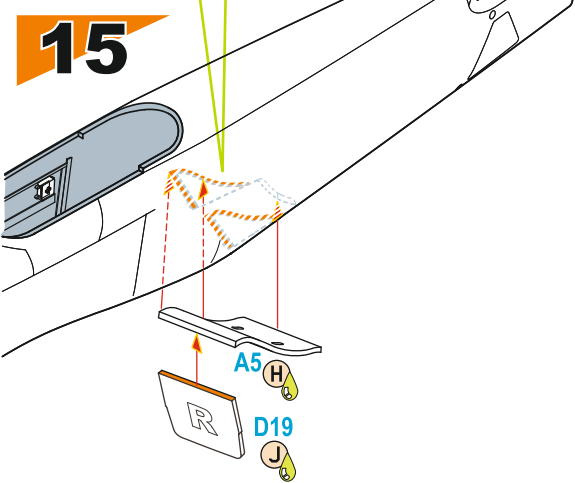

16

Step 10

Step 11

Step 2

Step 7

Step 5

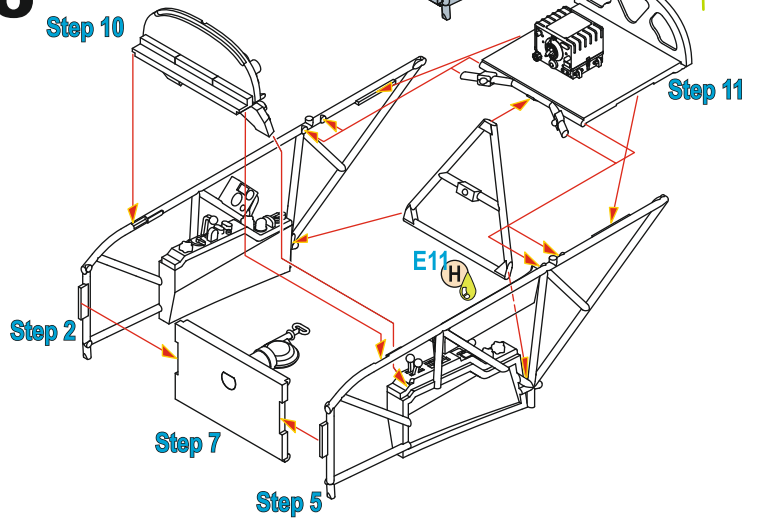

17

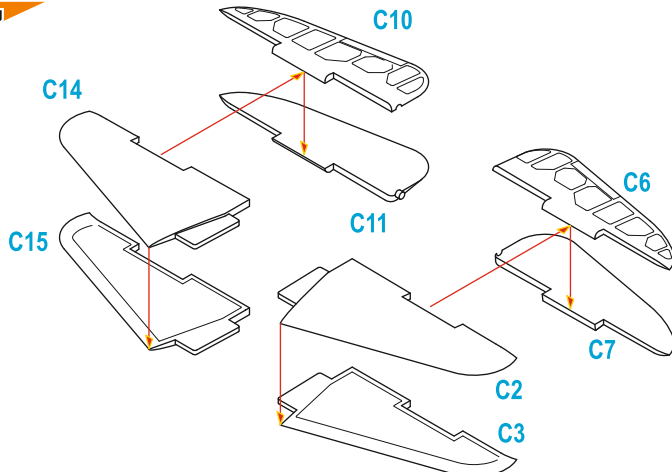

18

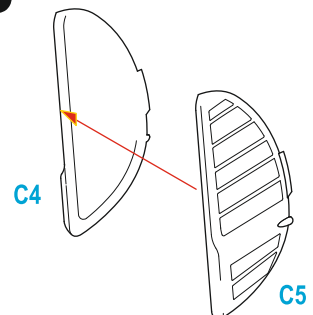

19

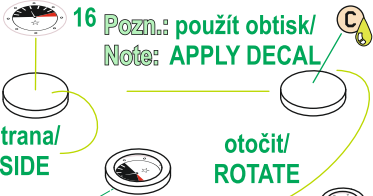

16 Pozn.: použít obtisk/
Note: APPLY DECAL

CP3

Pozn.: spodní strana/
Note: UNDERSIDE

otočit/
ROTATE

Step 20



Step 19

Pozn.: orientace dílu/
Note: ORIENTATION
OF THE PART

směr letu/
FORWARD

20

Pozn.: použít obtisk/
Note: APPLY DECAL

4

CP3

Step 21



Step 19

21

Pozn.: použít obtisk/
Note: APPLY DECAL

5

CP3

otočit/
ROTATE

Pozn.: spodní strana/
Note: UNDERSIDE

otočit/
ROTATE

22

B2

Pozn.: orientace dílu/
Note: ORIENTATION
OF THE PART

směr letu/
FORWARD

Info
Step 15

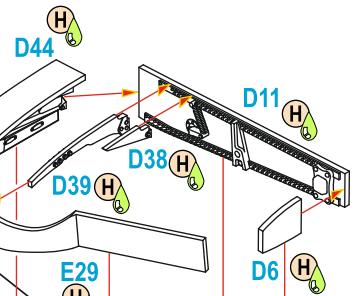
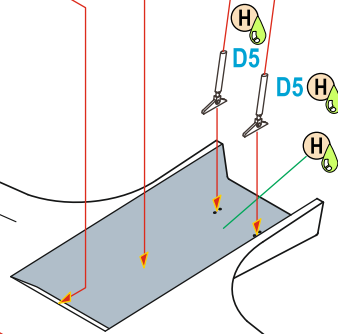
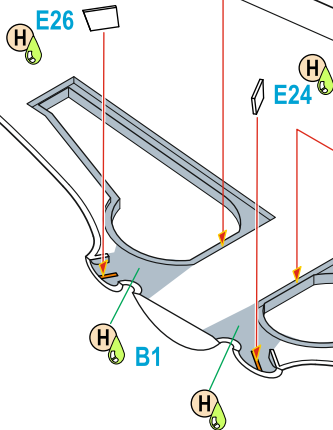
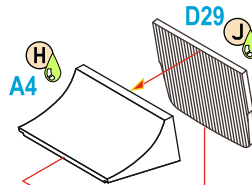
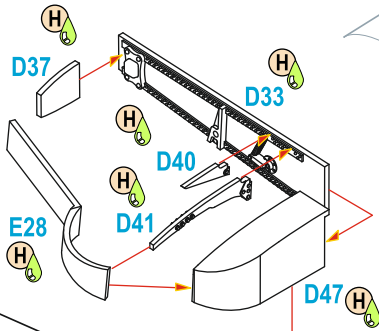

23

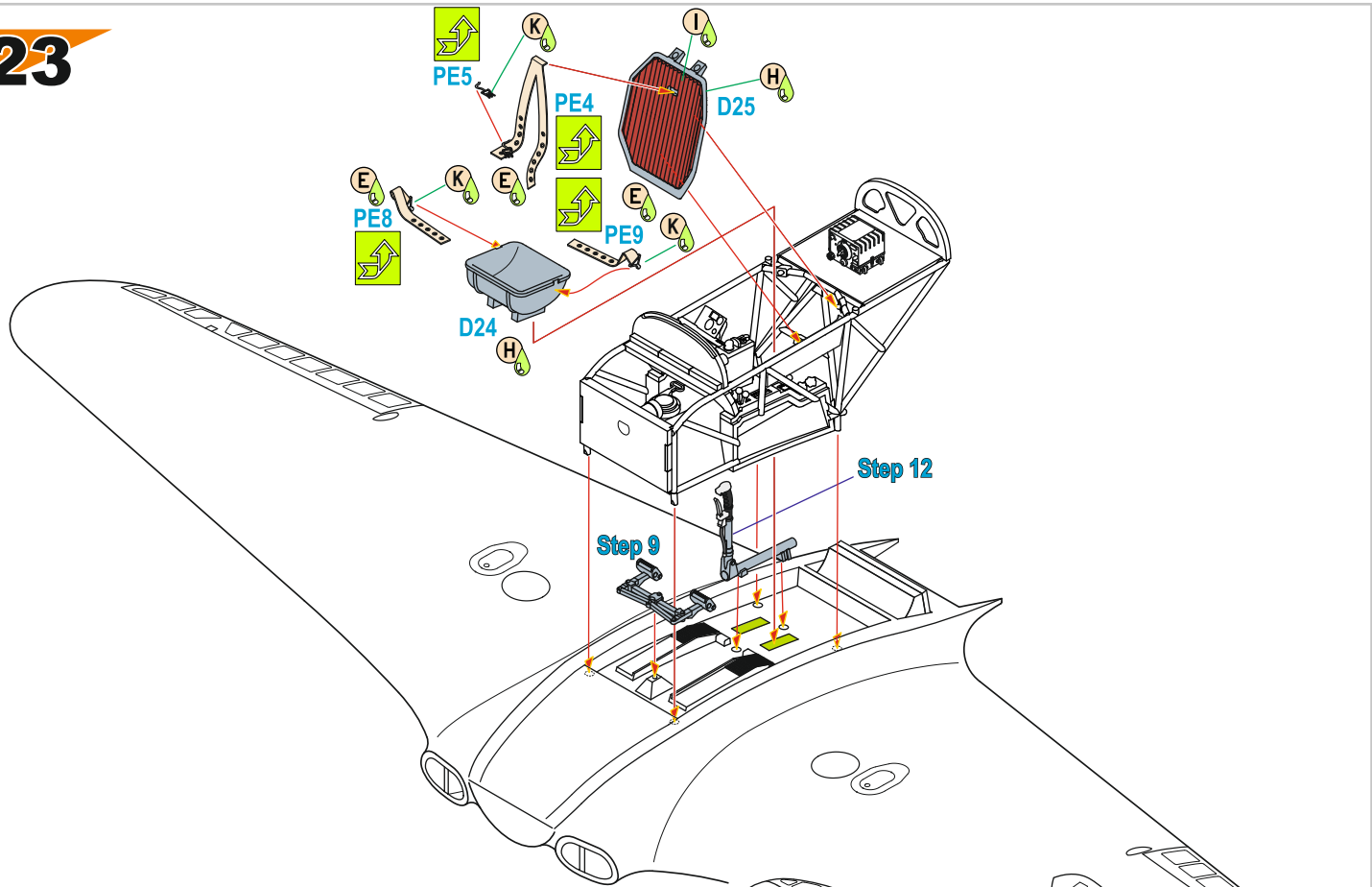

24

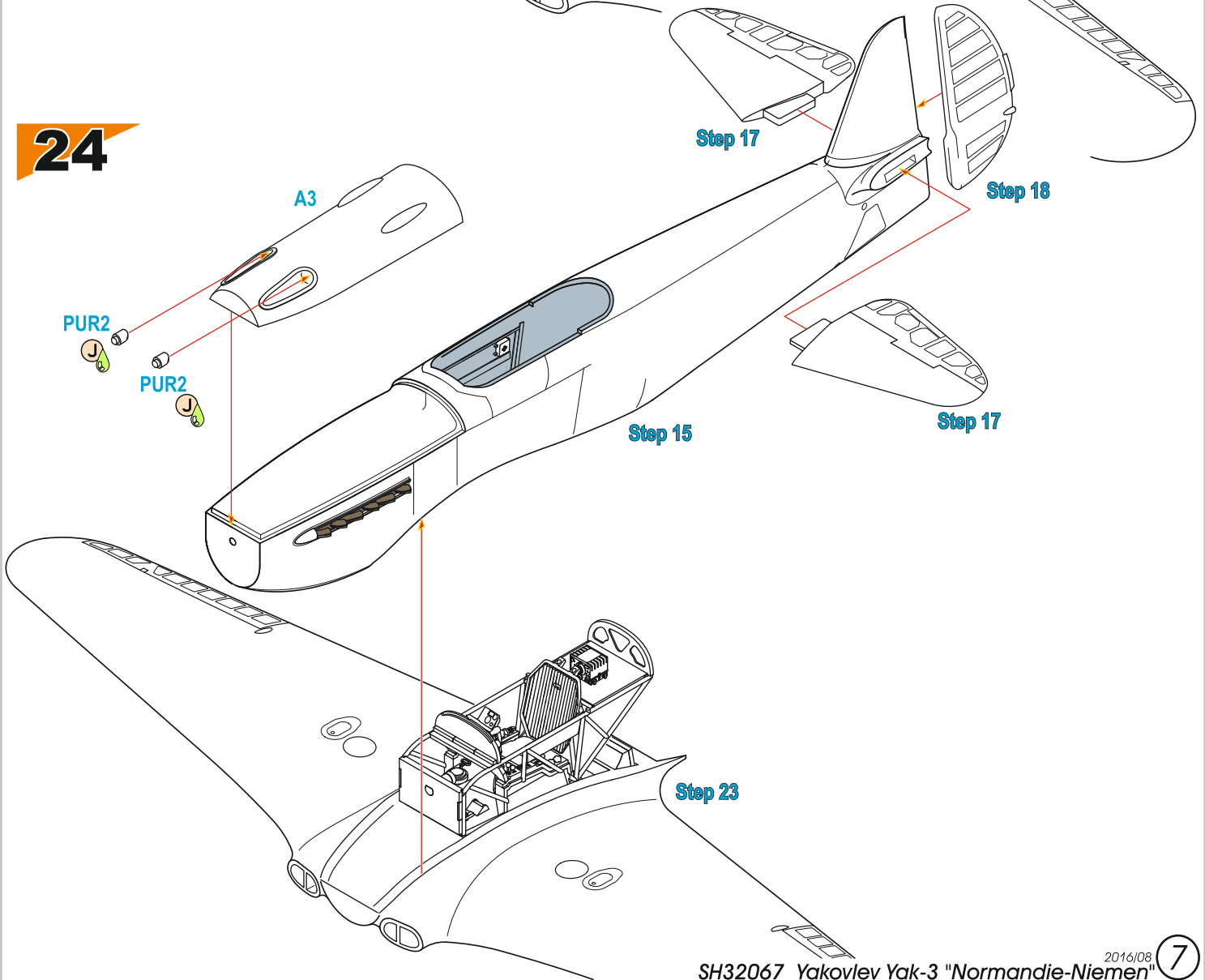

25

Info

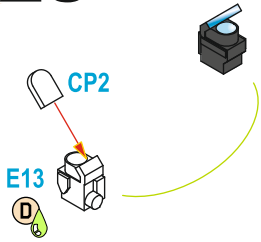

Info
PE6

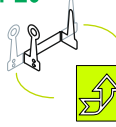

26

Step 25

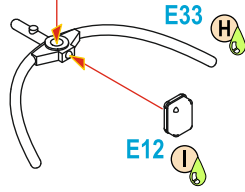

27

?

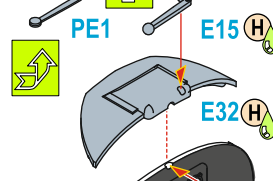

Info
Step 10

Info

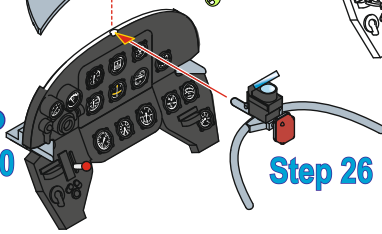

Step 26

28

Step 27

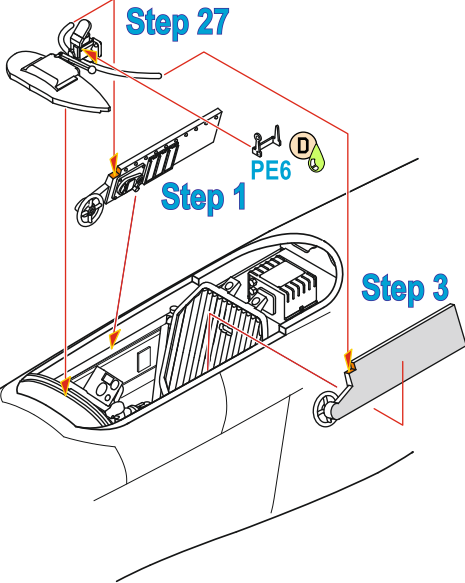

29

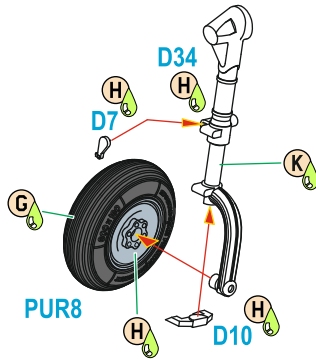

30

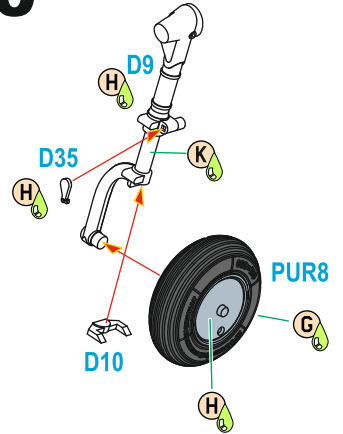

31

**Pozn.: pravá podvozková šachta/
Note: STBD WHEEL WELL**

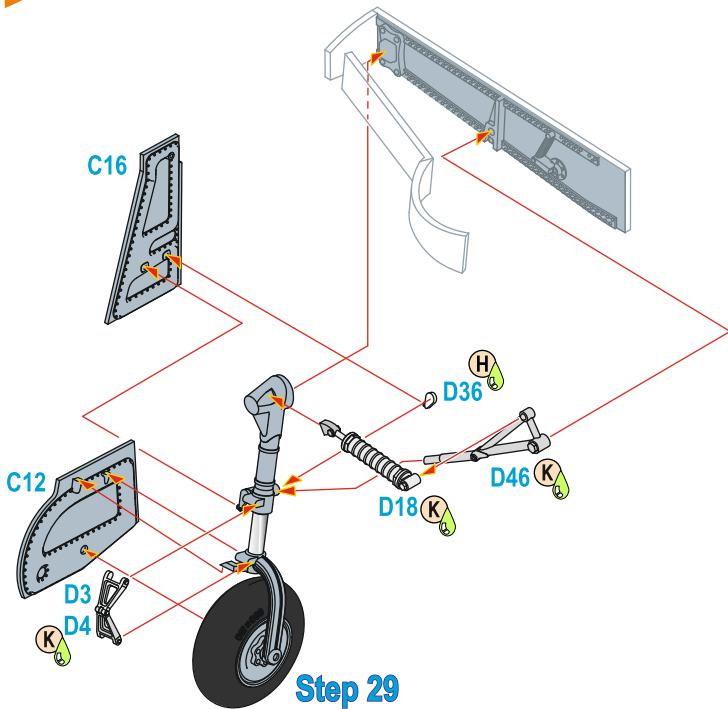

32

**Pozn.: levá podvozková šachta/
Note: PORT WHEEL WELL**

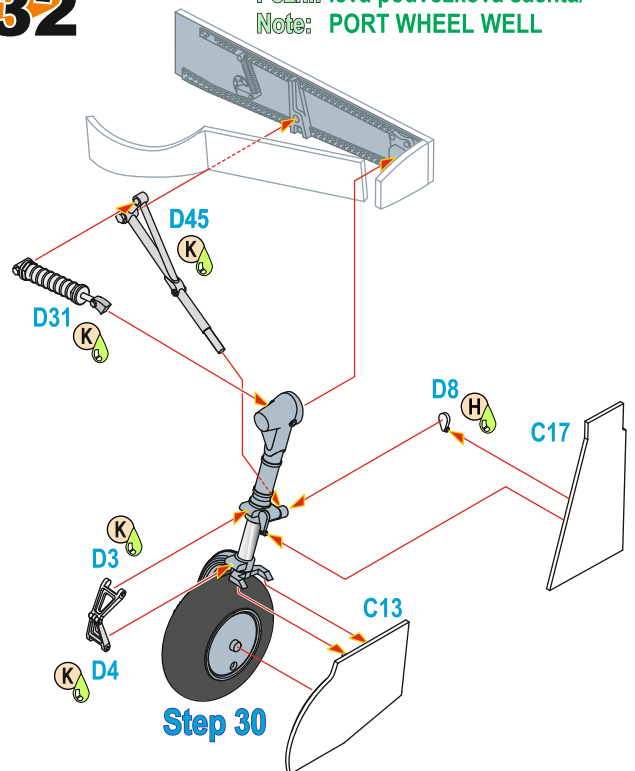

33

Step 31

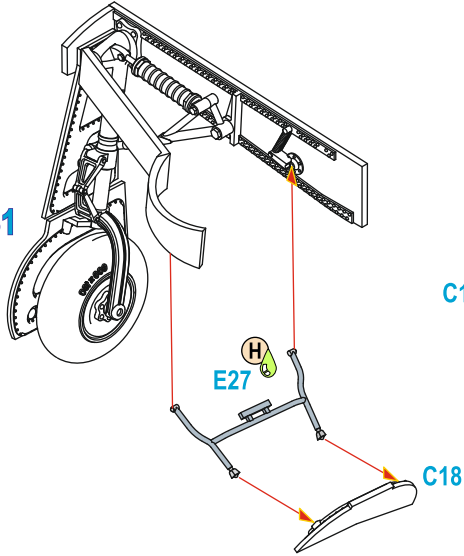

34

Step 32

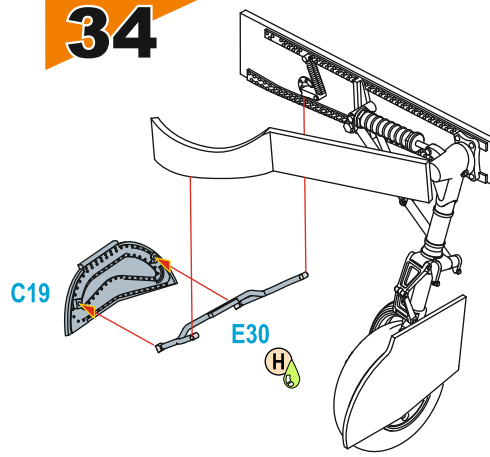

35

pohľad zspoda/
BOTTOM VIEW

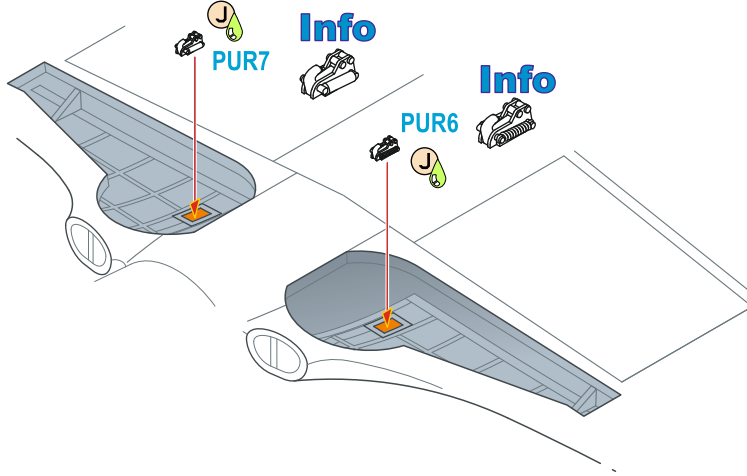

36

Step 33

Step 34

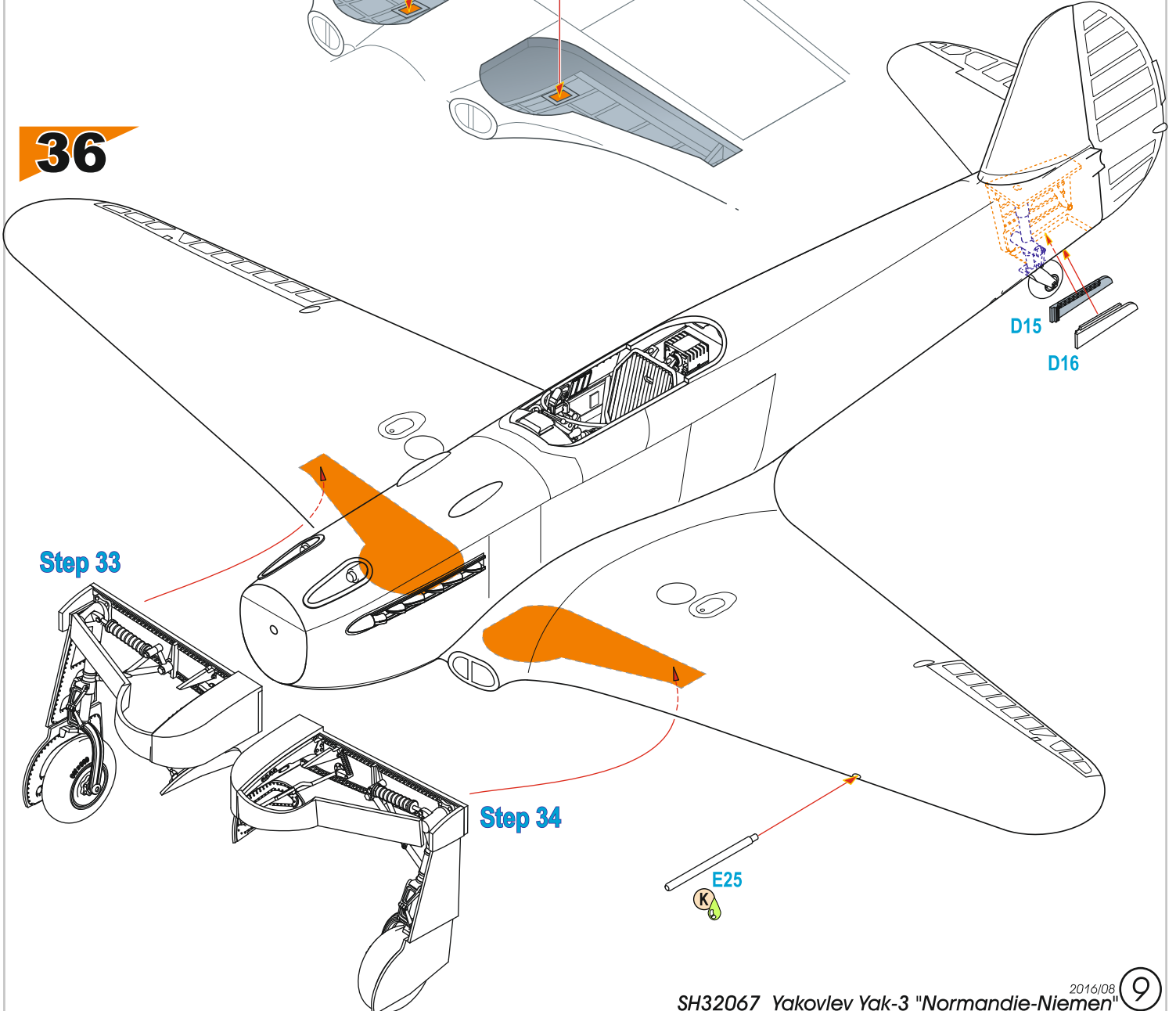

D15

D16

E25

37

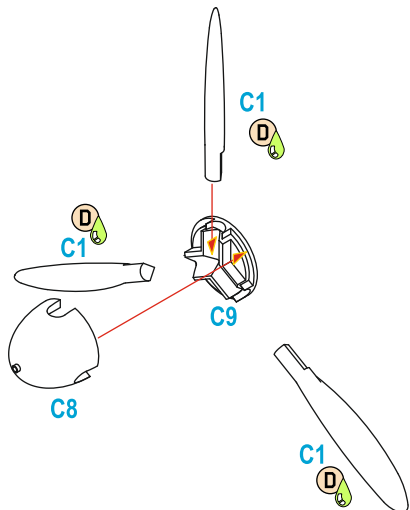

38

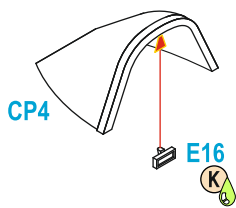

Special Hobby offer for 1/32 Yak-3 kit this nice resin figure F32318 Soviet Yak-3 Pilot running towards his aircraft



more at www.specialhobby.eu

39

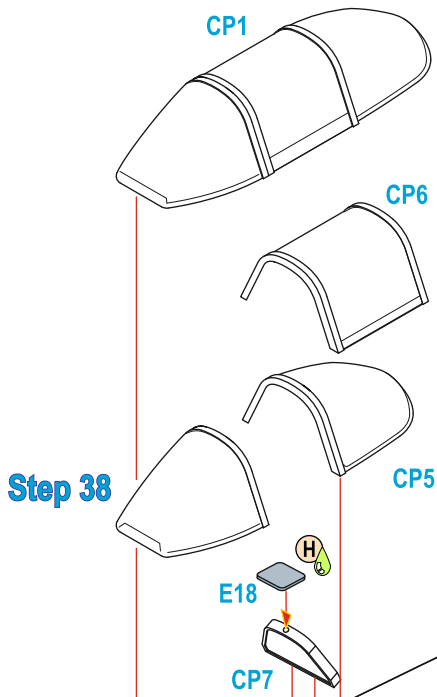

Step 38

Step 37

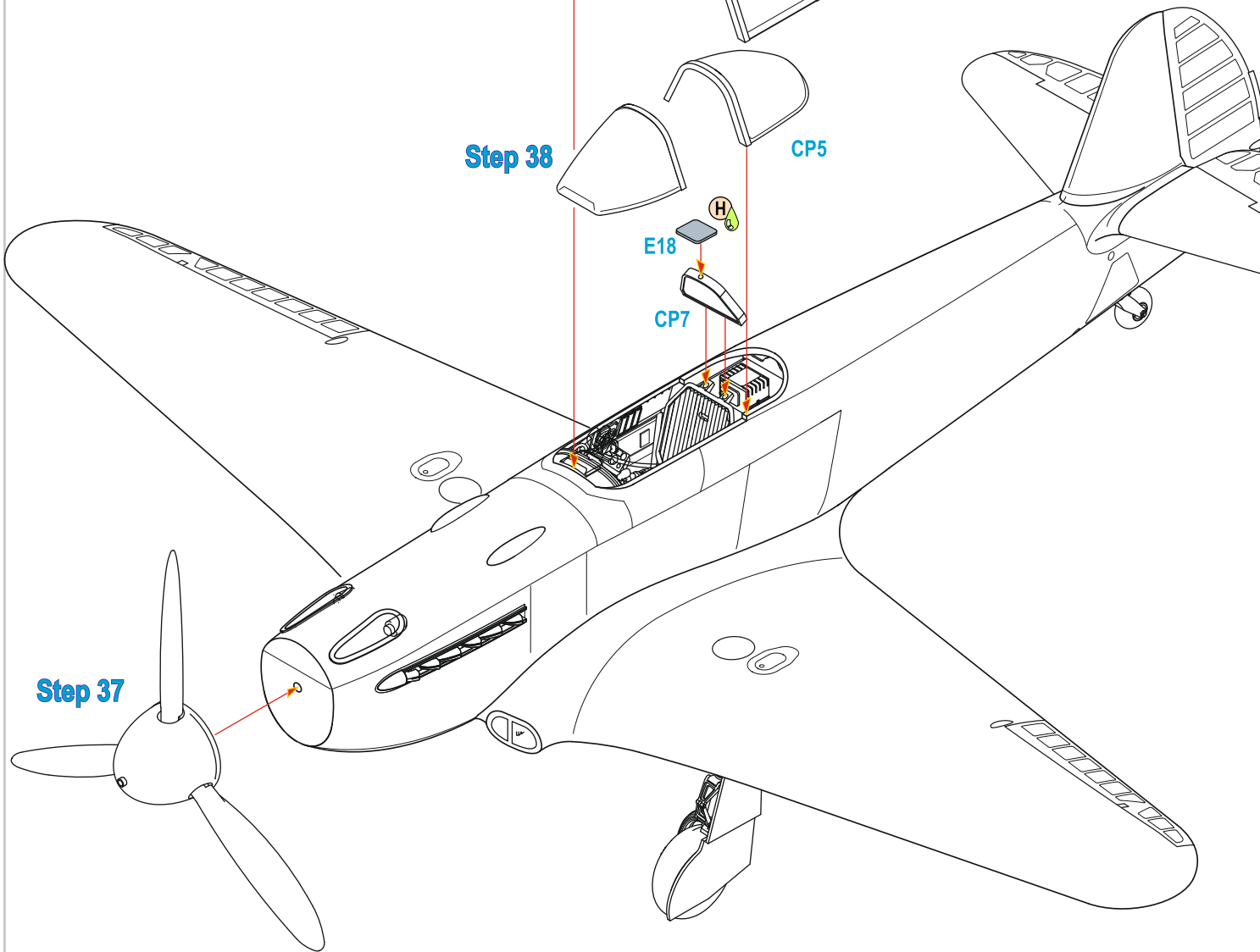

40

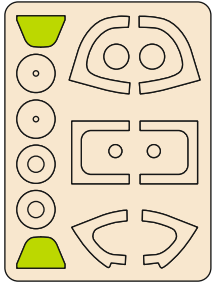

Použití masek/ MASKS APPLICATION

42

41

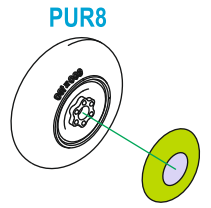
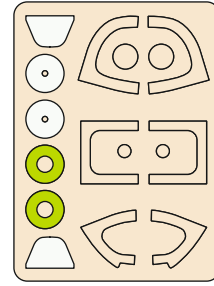
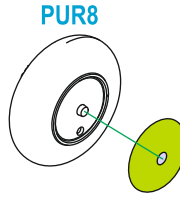
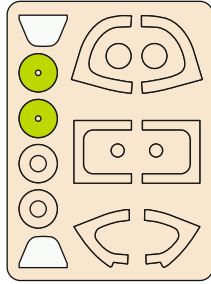

43

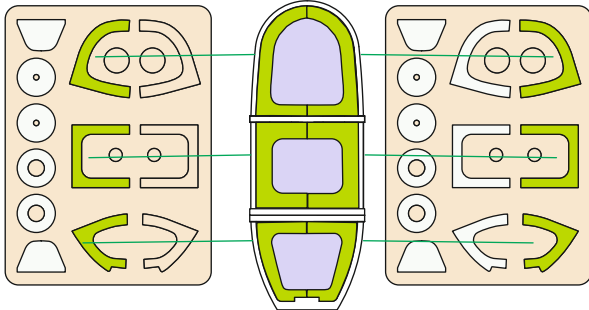

CP1

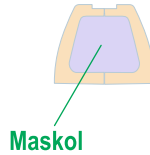

Maskol

44

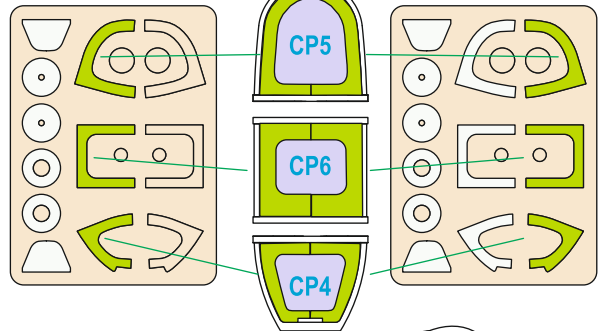

CP5

CP6

CP4

45

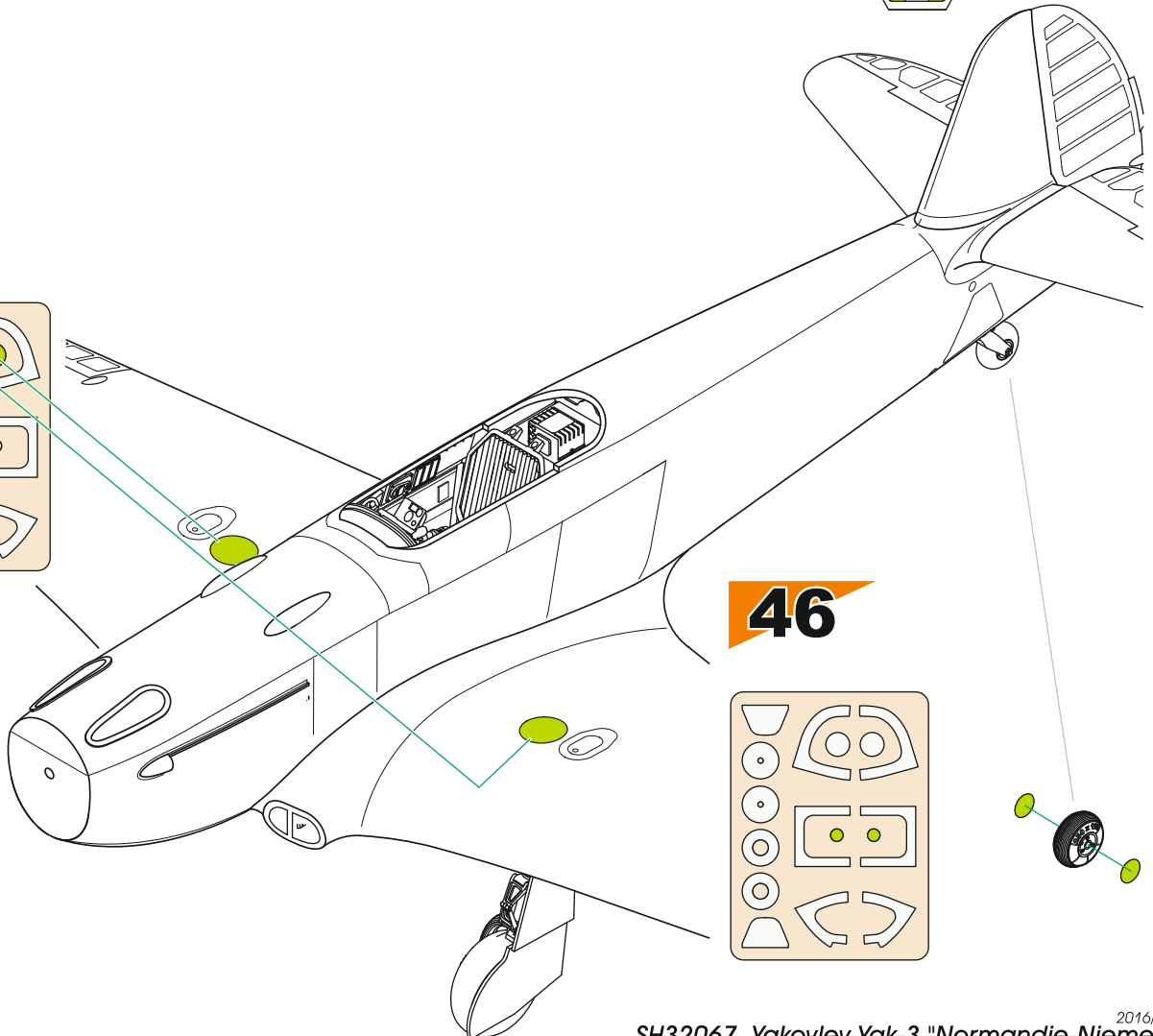
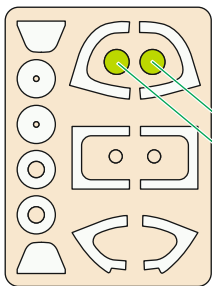

46

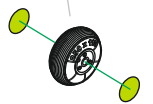
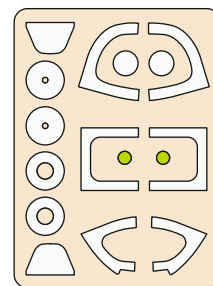

Jak-3, bílá šest, 1. letka pluku Normandie-Němen, podzim 1944, Sterki, Litva. Na tomto stroji dosáhl Lt. Marcel Albert, v té době velitel 1. letky, svých posledních vítězství z celkem 23 jistých a 2 pravděpodobných dosažených ve druhé světové válce. To ho řadí v počtu sestřelů na druhé místo v žebříčku francouzských stíhačů (za P. Clostermanna). Stal se nositelem Řádu osvobození a Hrdinou Sovětského Svazu. Po válce Marcel Albert odešel z řad Armée de l'Air a pracoval krátce jako francouzský letecký atašé v Praze.

Yak-3, white "6", 1 Sqn, Normandie-Niemen regiment, Autumn 1944, Sterki, Lithuania. When flying this machine, Lt. Marcel Albert, the then CO of the 1st Squadron, gained his last victories from his total of 23 confirmed, and 2 probable kills during WW2. It makes him the second highest scoring of French fighter pilots, after Pierre Clostermann. He was awarded with the Order of the Liberation (Ordre de la Libération) and also became a Hero of the Soviet Union. After the war he left the Armée de l'Air and for a short period of time worked as the French air attaché in Prague.

CAMO. A

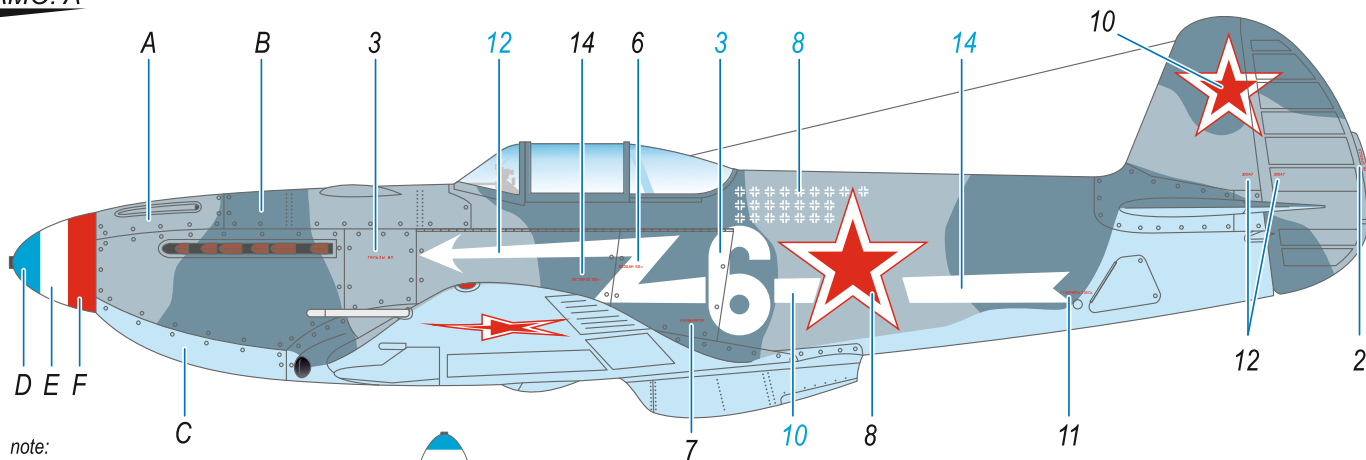

note:
black number decals (15) - use sheet 1
blue number decals (15) - use sheet 2

pozn:
obtisky s černými čísly (15) - aršík č.1
obtisky s modrými čísly (15) - aršík č.2

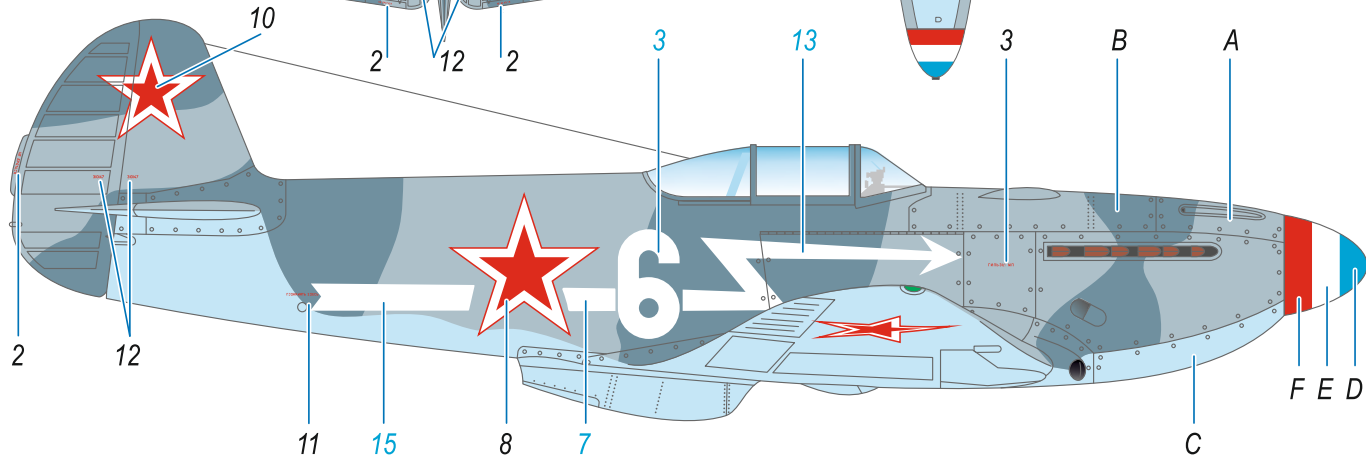
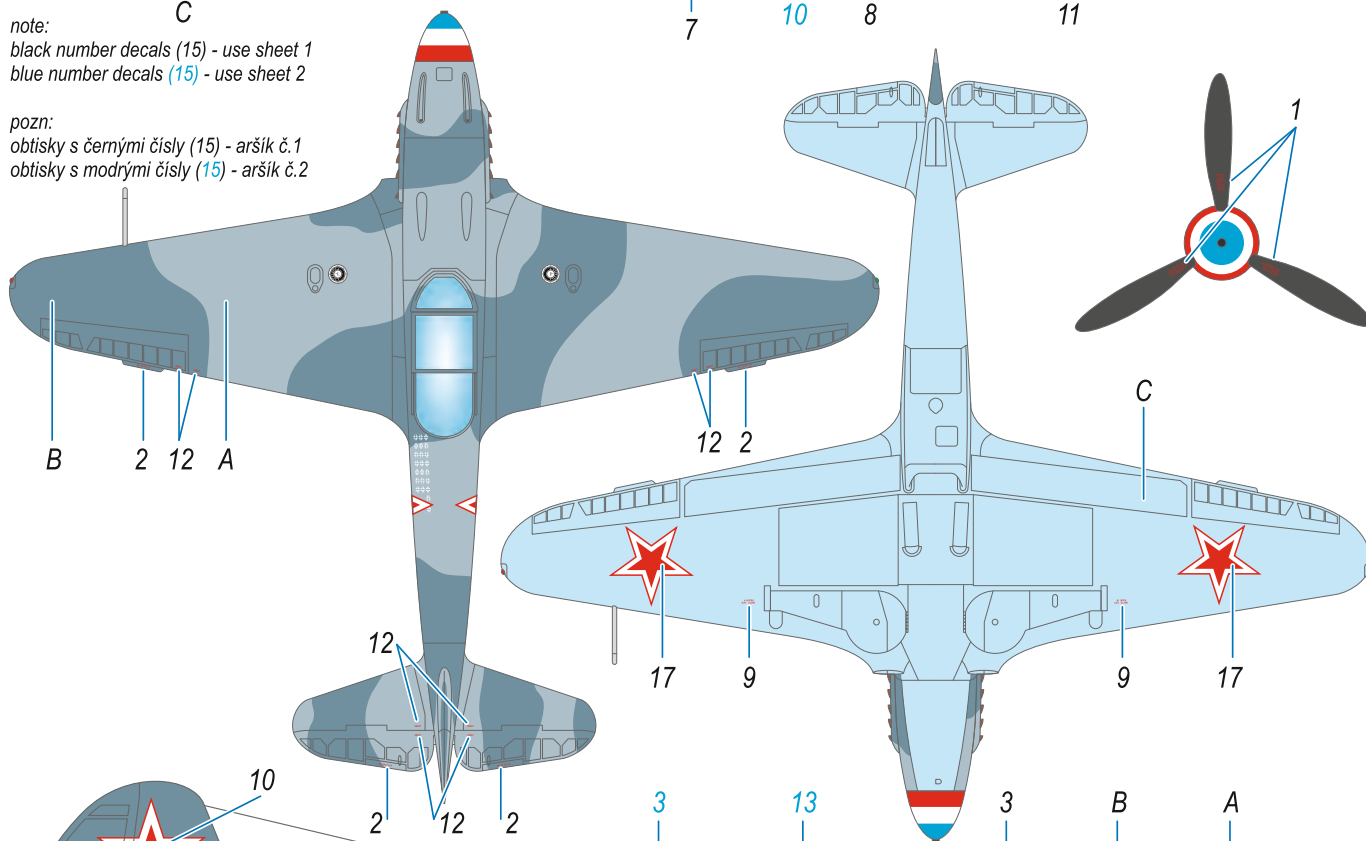

- | | | | | | |
|--|---|---|-----------------------------------|-----------------------------------|----------------------------------|
| A modrošedá
Blue Grey
H308/C308 | B tmavě šedá
Dark Grey
H317/C317 | C sv. modrá
Lt. Blue
H323/C323 | D modrá
Blue
H25/C34 | E bílá
White
H11/C32 | F červená
Red
H3/C3 |
|--|---|---|-----------------------------------|-----------------------------------|----------------------------------|



Jak-3, bílá dvojitá nula, Východní Prusko, přelom let 1944 a 1945. Stroje označené dvojitou nulou jako osobním symbolem používalo eso Cdt. Louis Delfino (16 nebo 17 vítězství + 5 pravděpodobných). V rámci Normandie-Niemen to bylo několik Jaků 3. L. Delfino se stal esem již v roce 1940, kdy létal na Blochu MB.152C.1 (sedm jistých a 3 pravděpodobné sestřely). Během služby v letectvu Vichy přidal 12.8. 1942 k těmto vítězstvím sestřel britského Wellingtonu. Během bojů v Sovětském svazu dosáhl 8 až devíti jistých (prameny se rozcházejí) a jednoho pravděpodobného vítězství. Od 12.12. 1944 do 20.6.1945 velel celému pluku Normandie-Niemen a v čele jednotky se vrátil do Francie v červnu 1945.

Yak-3, white "Double Zero" East Prussia, 1944-45. Several machines marked with the Double Zero personal marking were used by French ace Cdt. Louis Delfino (16 or 17 victories + 5 probables). L. Delfino had become an ace already in 1940 while flying a Bloch MB.152C.1 fighter (7 confirmed victories + 3 probables). Later, when flying for the Vichy regime, he added another victory over a British Wellington on August 8, 1942. In the Soviet Union he claimed another 8 or 9 (sources differ) and one probable. From December 12, 1944 till June 20, 1945, he was the CO of the Normandie Niemen regiment and led the unit on its journey back to France in July 1945.

CAMO. B

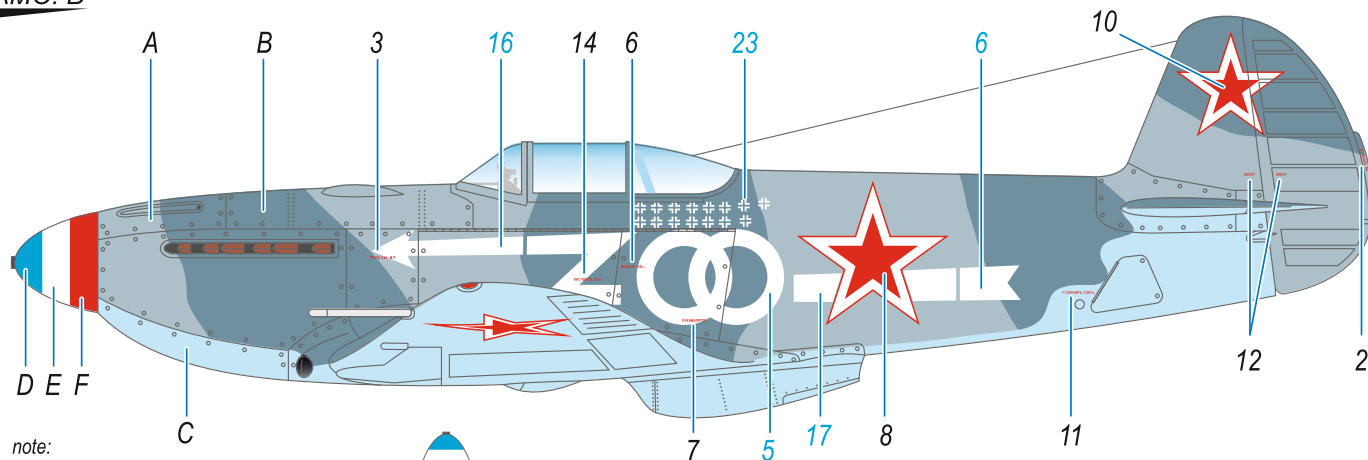

note:
black number decals (15) - use sheet 1
blue number decals (15) - use sheet 2

pozn:
obtisky s černými čísly (15) - aršík č.1
obtisky s modrými čísly (15) - aršík č.2

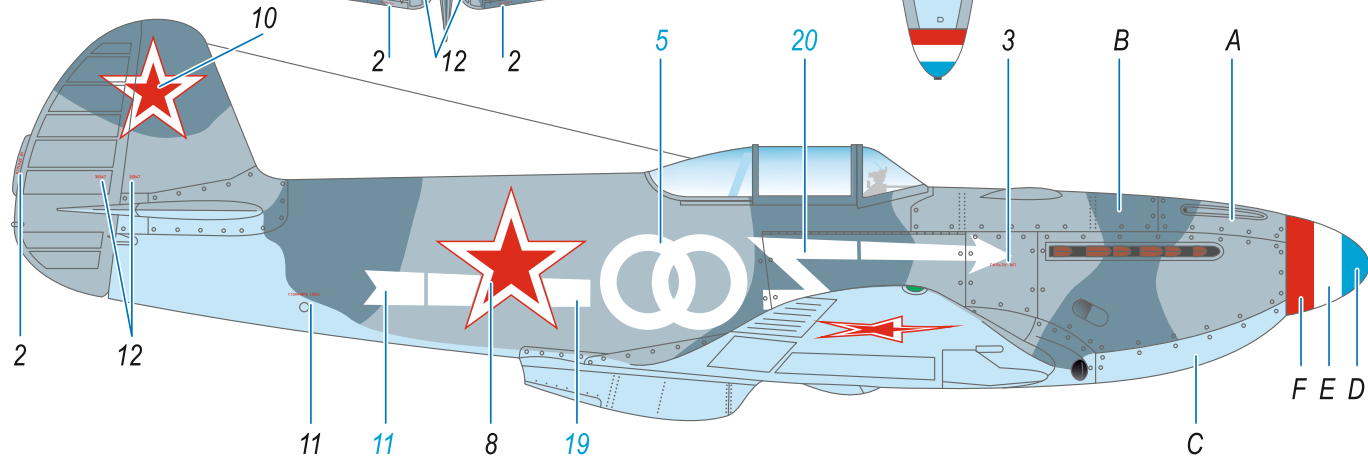
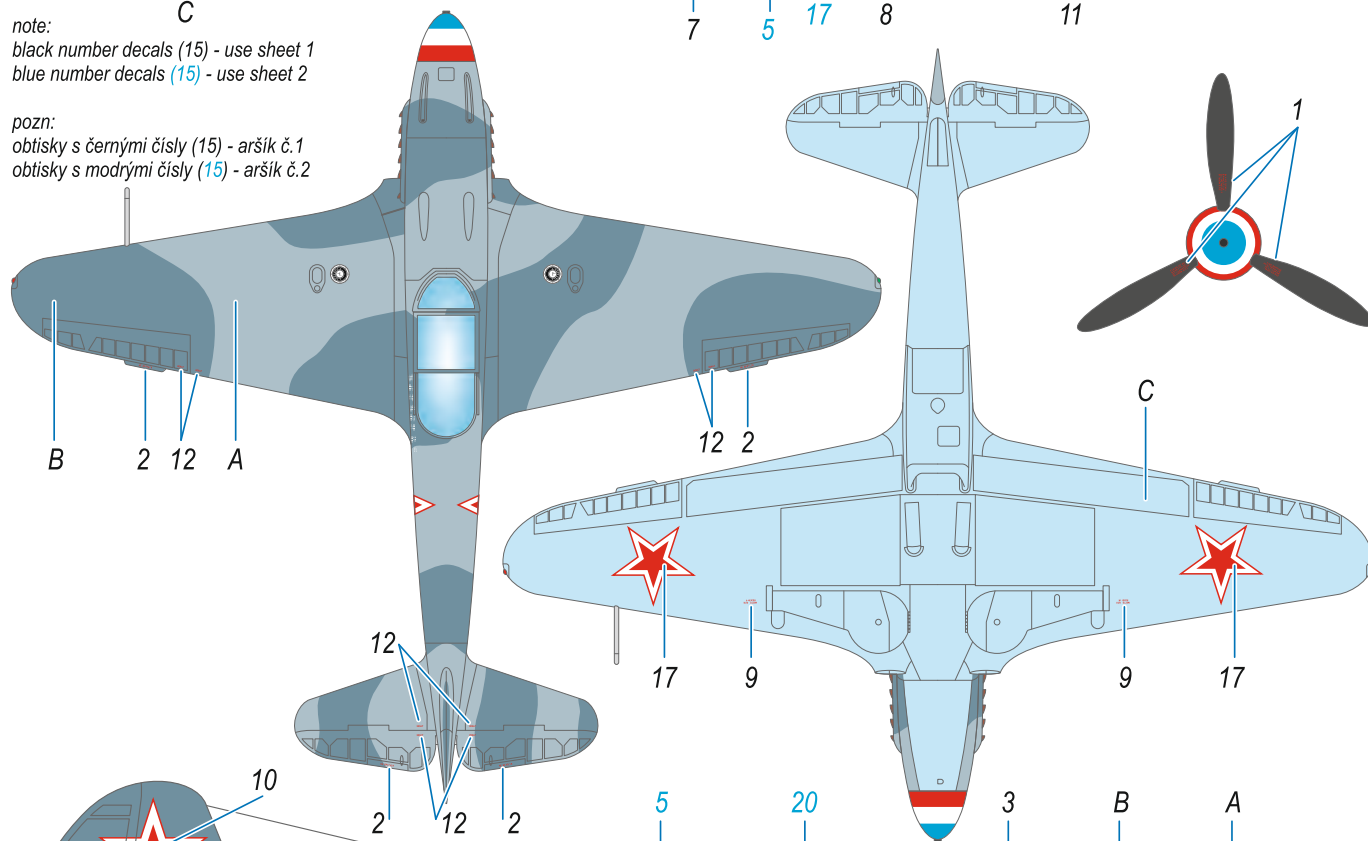

- | | | | | | |
|--|---|---|-----------------------------------|-----------------------------------|----------------------------------|
| A modrošedá
Blue Grey
H308/C308 | B tmavě šedá
Dark Grey
H317/C317 | C sv. modrá
Lt. Blue
H323/C323 | D modrá
Blue
H25/C34 | E bílá
White
H11/C32 | F červená
Red
H3/C3 |
|--|---|---|-----------------------------------|-----------------------------------|----------------------------------|



Jak-3, bílá 24, Roland de la Poype, hrdina Sovětského svazu, Východní Prusko, podzim 1944. R. de la Poype na tomto jaku bojoval od srpna do prosince 1944. V té době dosáhl polovinu ze svých celkem 16 vítězství. 27. listopadu 1944 mu byl udělen titul hrdina Sovětského Svazu. V prosinci 1944 se R. de la Poype vrátil do Francie.

Yak-3, white "24", Roland de la Poype, Hero of the Soviet Union, Eastern Prussia, Autumn 1944. R. de la Poype would fly and fight in this Yak from August 1944 until December 1944, achieving in that period half of his total score of 16 victories. On November 27, 1944, he was awarded the Hero of the Soviet Union title, and in December the same year he returned to France.

CAMO. C

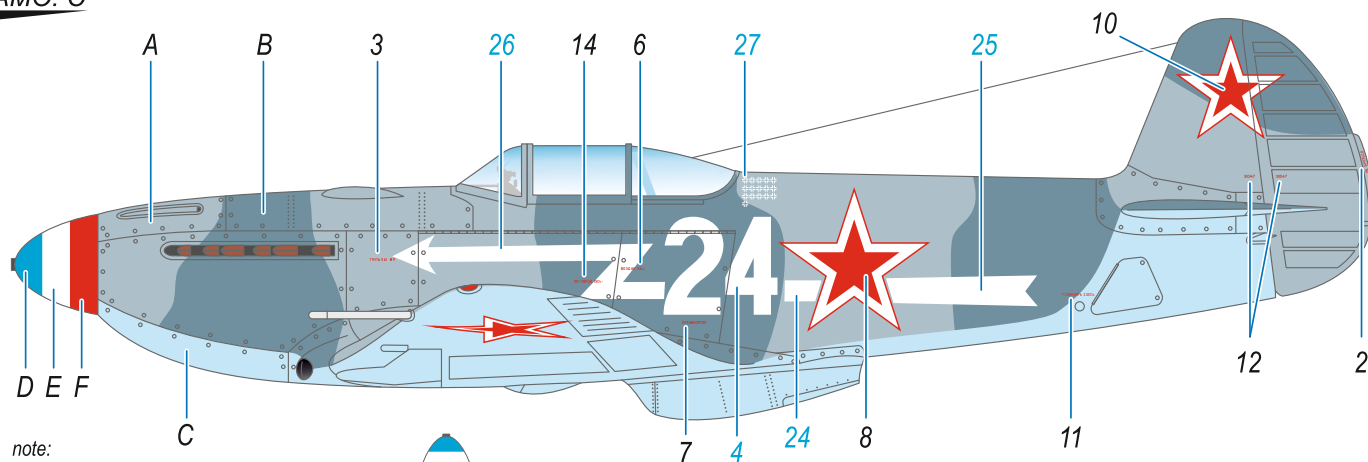

note:
black number decals (15) - use sheet 1
blue number decals (15) - use sheet 2

pozn:
obtisky s černými čísly (15) - aršík č.1
obtisky s modrými čísly (15) - aršík č.2

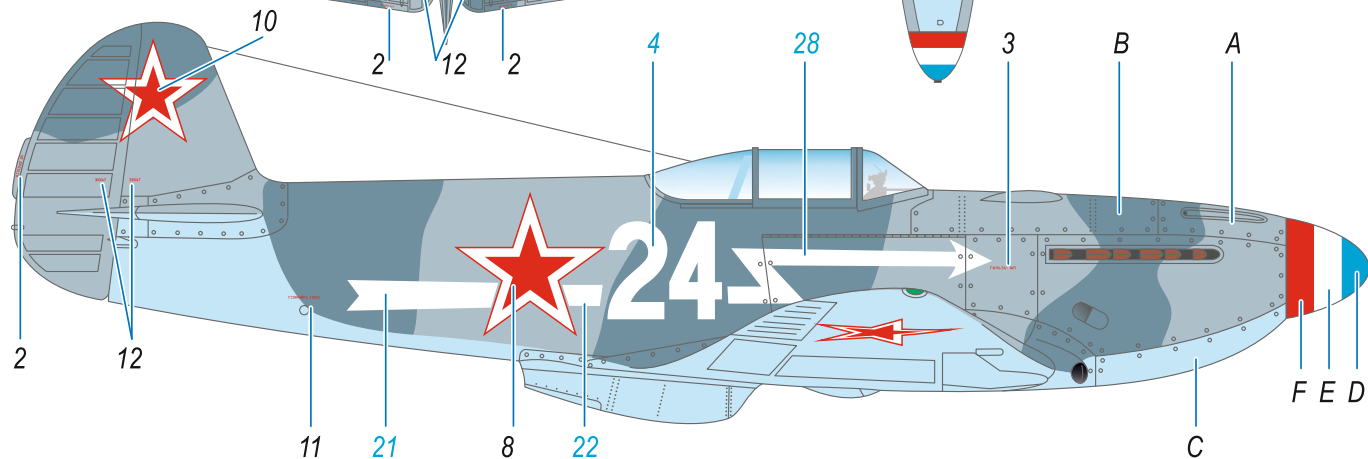
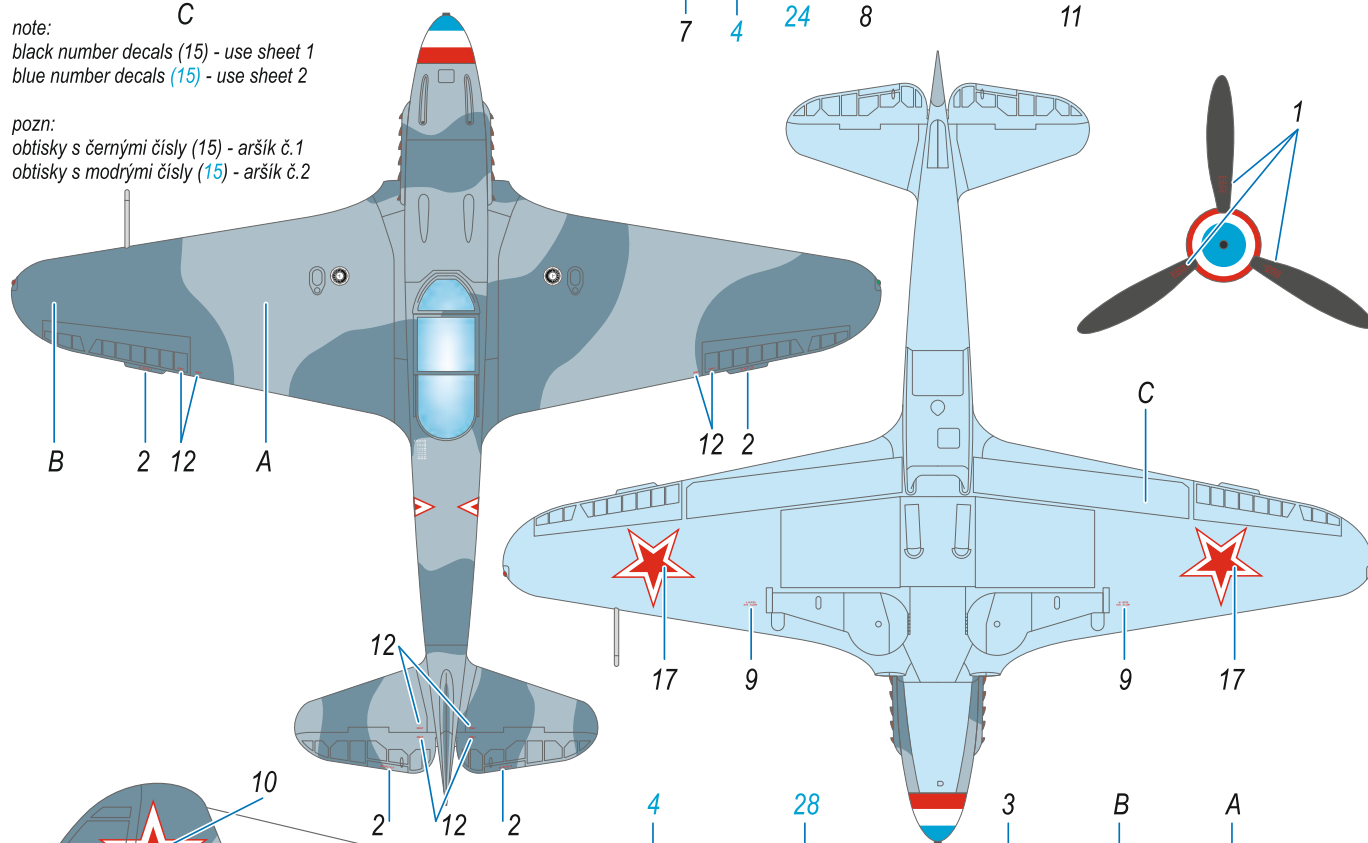

- | | | | | | |
|--|---|---|-----------------------------------|-----------------------------------|----------------------------------|
| A modrošedá
Blue Grey
H308/C308 | B tmavě šedá
Dark Grey
H317/C317 | C sv. modrá
Lt. Blue
H323/C323 | D modrá
Blue
H25/C34 | E bílá
White
H11/C32 | F červená
Red
H3/C3 |
|--|---|---|-----------------------------------|-----------------------------------|----------------------------------|



Jak-3, bílá 22, Asp. Pierre Douarre, letiště Le Bourget, Francie, červen 1945. P. Douarre dosáhl na Východní frontě dvou vítězství ve spolupráci (9. a 10. října 1944). Jeho bojové nasazení trvalo od 7. 1. 1944 až do triumfálního návratu pluku Normandie -Němci na pařížské letiště Le Bourget 20. června 1945. Několik dní po přeletu dostal letoun francouzskou trikoloru na kormidlo SOP. Blesk na levé straně trupu byl nestandardně otočen.

Yak-3, white "22", Asp. Pierre Douarre, Le Bourget airfield, France, June 1945. P. Douarre claimed two victories in cooperation over the Eastern front (on October 9 and 10, 1944). His battle assignment lasted from January 7, 1944 until the Normandie Niemen regiment's triumphant return to Le Bourget on June 20, 1945. A couple of days after their arrival to France, French colours were painted on the machine's rudder. Note also that the port side fuselage lightning marking was applied upside-down on this aircraft.

CAMO. D

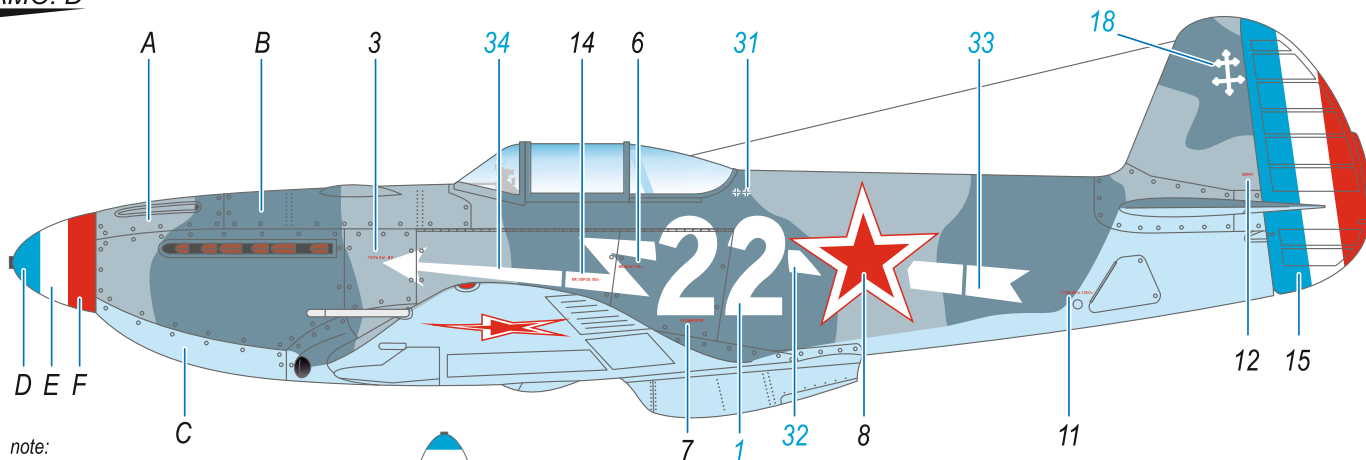

note:
black number decals (15) - use sheet 1
blue number decals (15) - use sheet 2

pozn:
obtisky s černými čísly (15) - aršík č. 1
obtisky s modrými čísly (15) - aršík č. 2

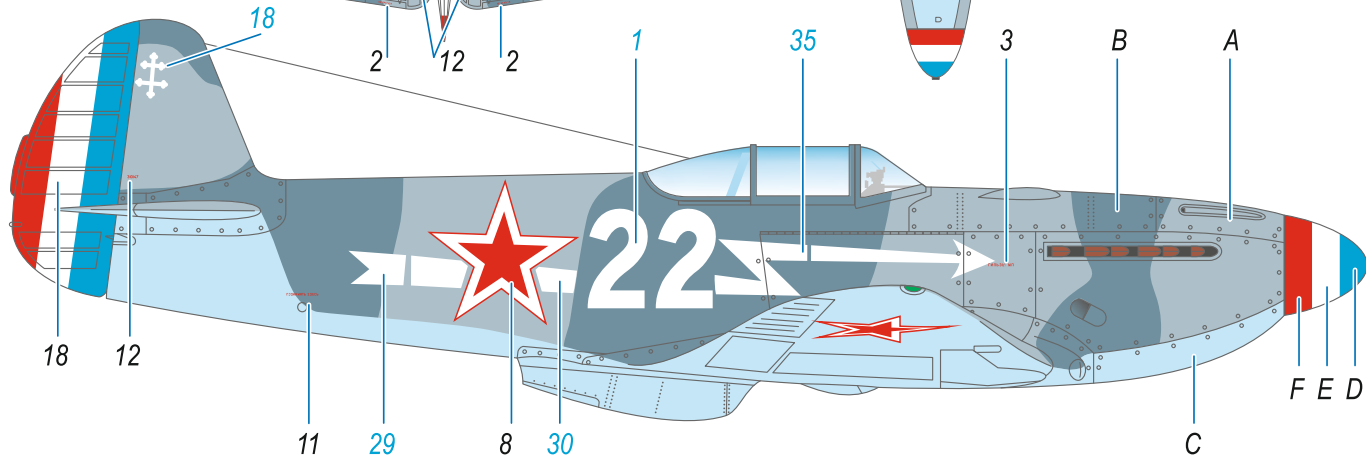
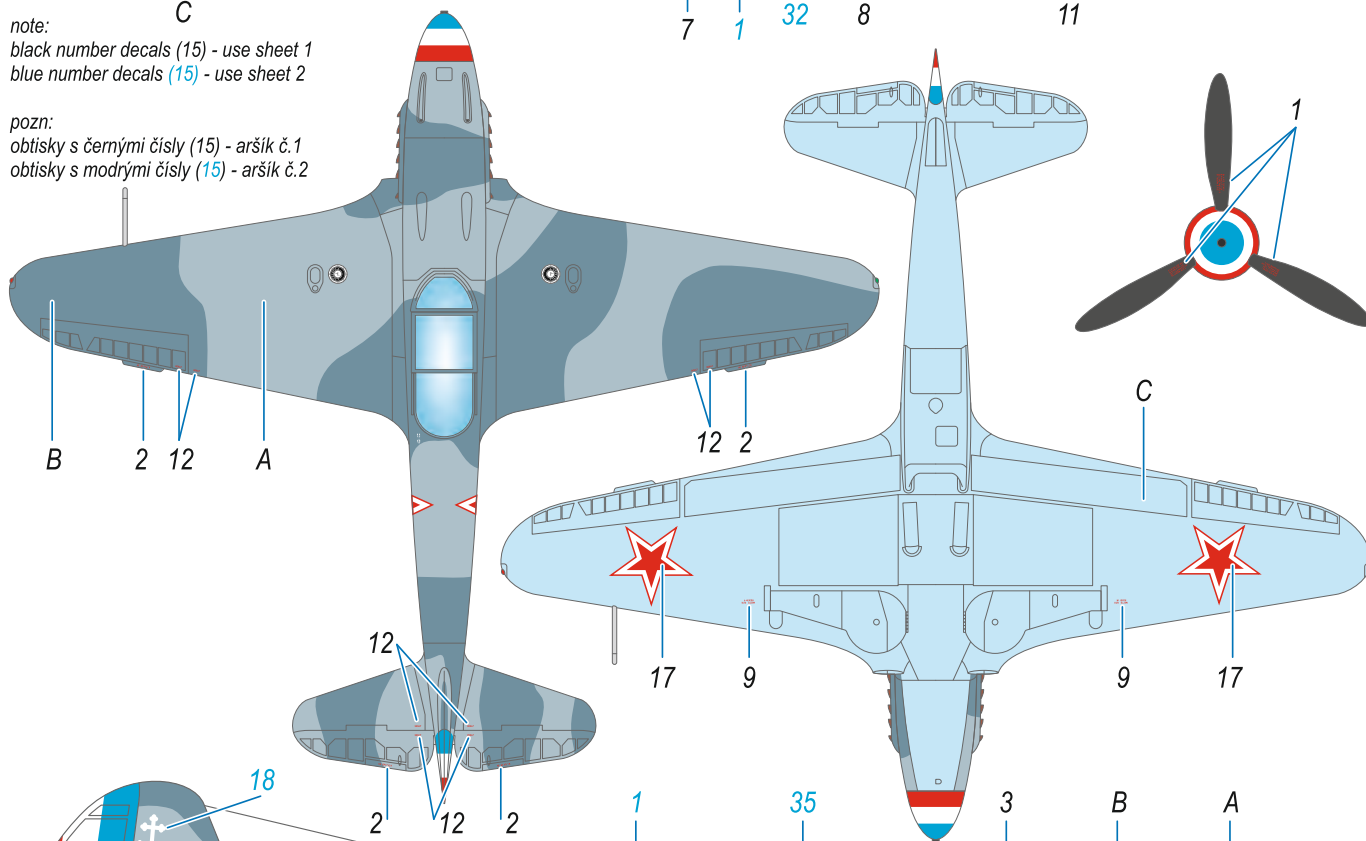

- | | | | | | |
|--|---|---|-----------------------------------|-----------------------------------|----------------------------------|
| A modrošedá
Blue Grey
H308/C308 | B tmavě šedá
Dark Grey
H317/C317 | C sv. modrá
Lt. Blue
H323/C323 | D modrá
Blue
H25/C34 | E bílá
White
H11/C32 | F červená
Red
H3/C3 |
|--|---|---|-----------------------------------|-----------------------------------|----------------------------------|



Jak-3, bílá 4, Lt. Roger (Robert) Marchi, Litva, léto 1944. Exelentní akrobat R. Marchi dosáhl celkem 13 vítězství. Zahynul při letecké nehodě 17. července 1946.

Yak-3, white "4", Lt. Roger (Robert) Marchi, Lithuania, Summer 1944. R. Marchi, an outstanding aerobatic pilot, scored a total of 13 victories. He lost his life in an air accident on July 17, 1946.

CAMO. E

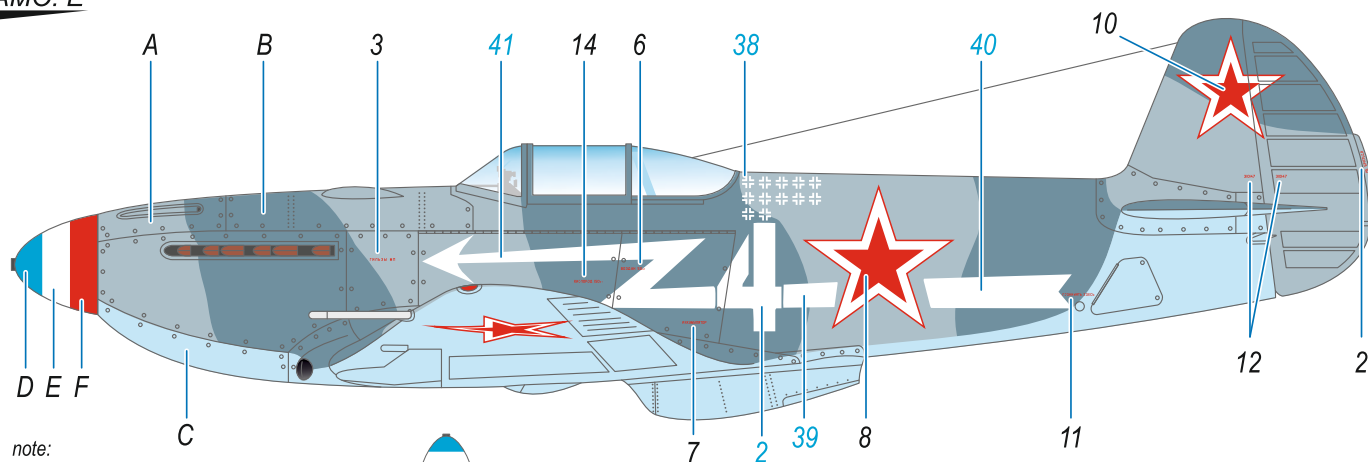

note:
black number decals (15) - use sheet 1
blue number decals (15) - use sheet 2

pozn:
obtisky s černými čísly (15) - aršík č.1
obtisky s modrými čísly (15) - aršík č.2

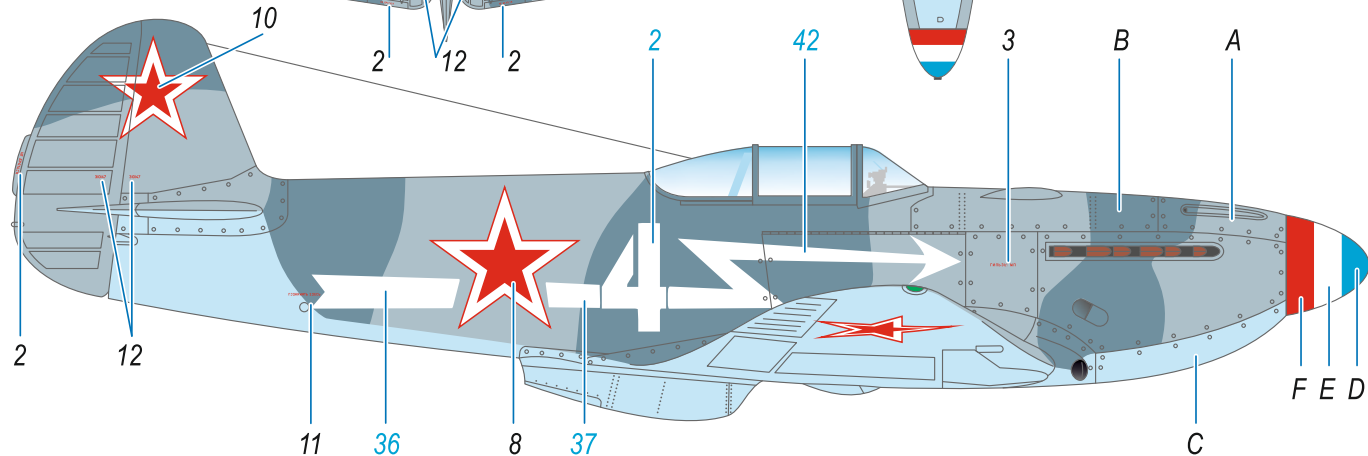
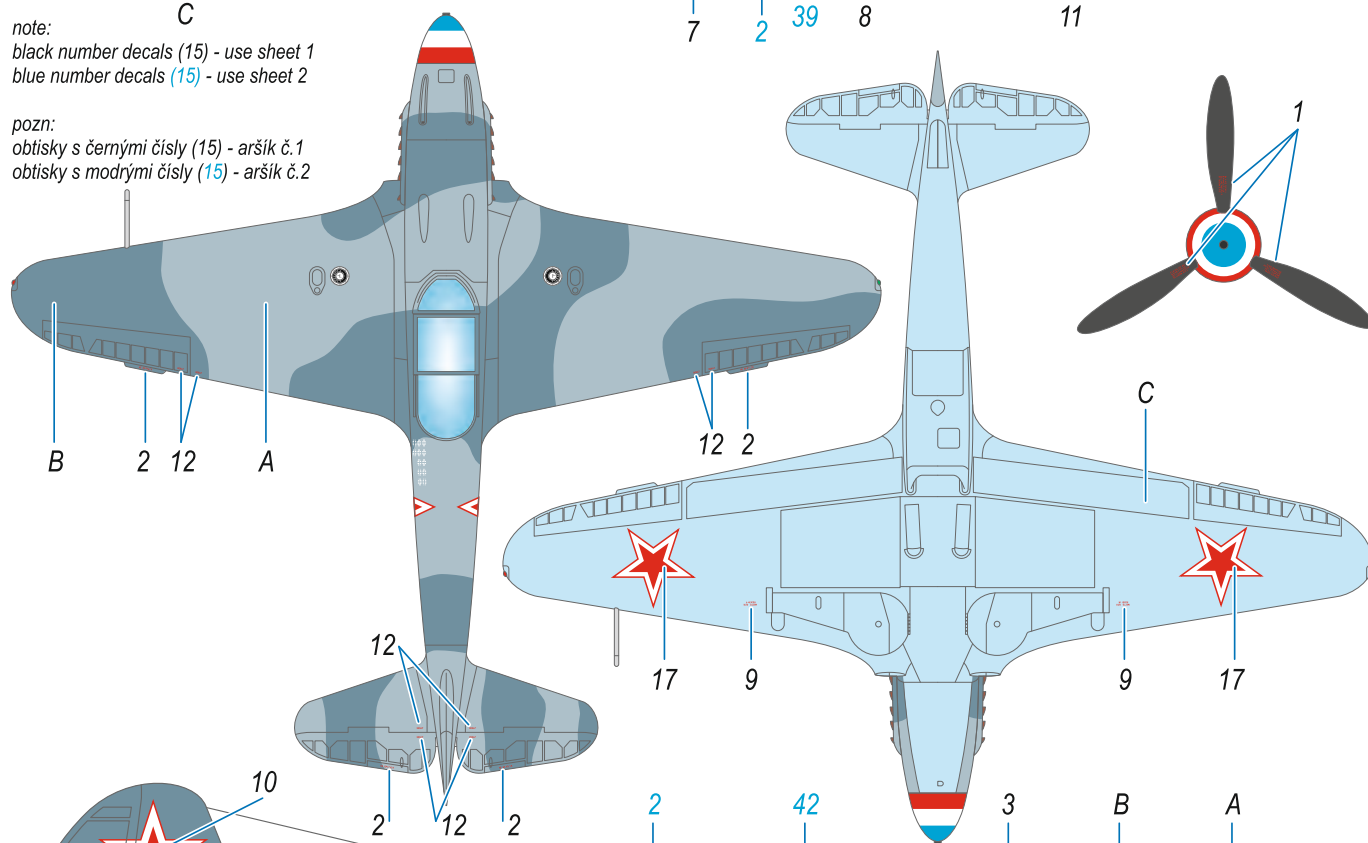

- | | | | | | |
|--|---|---|-----------------------------------|-----------------------------------|----------------------------------|
| A modrošedá
Blue Grey
H308/C308 | B tmavě šedá
Dark Grey
H317/C317 | C sv. modrá
Lt. Blue
H323/C323 | D modrá
Blue
H25/C34 | E bílá
White
H11/C32 | F červená
Red
H3/C3 |
|--|---|---|-----------------------------------|-----------------------------------|----------------------------------|

