

## B-12A Bomber 'Yellow Wings over America'

1/72

### CZ

Prototyp bombardéru B-10 se poprvé vznesl do vzduchu 16. února 1932. Jeho konstrukce se vyznačovala několika významnými inovacemi, drak stroje byl celokovový s plně kapotovanými motory a zatahovacím podvozkem. Pozice střelců byly také již zakryté a bomby se nacházely ve vnitřní pumovnici, což vše přispělo k faktu, že B-10 byl rychlejší než soudobé stíhačky. Ačkoliv byl B-10 postaven jen v relativně malém počtu, jeho přínos pro USAAC byl vpravdě revoluční, především pro celokovovou konstrukci, poprvé použitou u bombardéru. V lednu roku 1933 americké letectvo objednalo 14 předseriových YB-10, následovalo 103 kusů verze B-10B z hlavní sériové produkce, které byly poháněné silnějšími motory Wright Cyclone R-1820-19 s výkonem 675hp. Bombardér B-10 byl uvolněn pro vývoz v červenci 1936 pod označením Model 139 a vybavený motory Wright. Mezi zákazníky byla Čína (devět strojů 139 WC), Argentina (22 strojů verze 139 WAN), Turecko (20ks WT), Siam (šest 139 WSM) a Holandská východní Indie, která obdržela největší počet strojů (13 ve verzi 139 WH-1, 26 verze 139 WH-2 a značně modifikovanou WH-3), dále stroj létal v Sovětském Svazu (jeden 139 WR) a Japonsku (také jeden 139 WJ). První dodávka 13 kusů holandské verze 139 WH-1 s registrací M501 až M513 byla následována dvaceti šesti kusy verze 139 WH-2 označenými M514 až M539. Všechny byly dodány letectvu Holandské východní Indie (ML-KNIL) nesoucí tehdejší standardní americké zbarvení, křídla ve žluté a trup modrý, a nesly holandské kokardy. Ty byly koncem roku 1939 nahrazeny rozměrnými oranžovými trojúhelníky. Od 16 srpna 1940 holandské bombardéry nesly kamuflážní nátěr ze dvou zelených na horních plochách a světle šedivou na spodních. Jejich role spočívala v obraně Holandské východní Indie, několik strojů jednotky 2-VI.G.III byly v prosinci 1941 poslány do Singapuru, kde vydržely dva měsíce. V roce 1936 si argentinská armáda objednala 22 bombardérů ve verzi Model 139 WAA s motory Wright Cyclone R-1820-G3 a také tři kusy Focke Wulfu Fw 58B Weihe pro cvičné lety. Bombardéry 139 WAA nesly označení 501 až 522 a zpočátku létaly z El Palomaru, od dubna 1938 byly převeleny pod Regimiento Aéreo 1 na základnu BAM Coronel Pringles. Stroje s označením 502, 509, 510 a 522 od konce dubna do 11 května 1943 operovaly z Rio Grande v Ohňové zemi. V září 1943 se letouny 508, 518 a 522 účastnily oslav nezávislosti v Santiagu de Chile. Stroje byly ponechány v barvě materiálu, nesly výsostně označení v podobě modro-bílých kokard na křídlech a trupu a velké vlajce na ocase a nesly kódové označení na trupu a na náběžných hranách křídel. Od října 1943 pak obdržely kamufláž zelenou na horních a světle modrou na spodních plochách a vlajka na svíslé ocasní ploše byla zmenšena. V lednu 1944 bylo doplněno písmeno B (Bombardero) před kódové číslo strojů. Stroje B-511 a B-510 byly ve službě poškozené a byly pro ně vyrobené nové, značně odlišné přídě. Poslední let argentinského 139 WAA (B-512) se uskutečnil 12 července 1954. Dalším vývojem z bombardéru B-10 vznikl typ B-12A. Jeho předseriová verze YB-12 (Model 139B) byla vybavena vodotěsnými komorami o objemu 250 či 500 galonů (950 / 1890 litrů) pro bezpečnější lety nad mořem. Pohon zajišťovala dvojice hvězdicových motorů Pratt & Whitney R-1690-11 Hornet, jejichž výkon 775hp dával strojům obdobné výkony jako slabší motory verze B-10B (218 mph, respektive 351 km/h). Celkem vyrobeno sedm kusů, pět zůstávalo ve službě ještě v dubnu 1940. Sériové kusy verze B-12A měly navíc možnost nést v pumovnici přídatnou palivovou nádrž a dolet tak mohli činit 1240 mil (2000km). Vyrobeno celkem 25 kusů, v dubnu 1940 jich létalo ještě 23.

TTD (139 WH-2):

rozpětí: 21.49m, délka 13.63m, plocha křídla 63m<sup>2</sup>, pohon: dva hvězdicové motory Wright Cyclone R-1820-G3 o výkonu 840hp, dostup: 5.182m, výzbroj: tři kulometry, až 1.029kg bomb.

### EN

The prototype first flew on February 16, 1932. The B-10 combined several innovations including an all-metal airframe, fully cowled engines, retractable landing gear, enclosed gun-turret, and internal bomb-bay, which made it faster than fighters then in service. Although built in relatively small numbers, the B-10 was revolutionary, and was the USAAC's first all-metal monoplane bomber. In January 1933, 14 pre-production YB-10s were ordered, then USAAC received 103 of the main production version, the B-10B, equipped with more powerful 675 hp Wright Cyclone R-1820-19 engines. The B-10 was cleared for export in July 1936 as the Model 139 with Wright engines. Customers included China (nine 139 WC), Argentina (22 139 WAA and 12 139 WAN), Turkey (20 139 WT), Siam (six 139 WSM), and the Dutch East Indies which was the biggest user (13 139 WH-1, 26 139 WH-2, and WH-3, largely modified), the Soviet Union (one 139 WR) and Japan (one 139 WJ). A first batch of 13 Model 139 WH-1, registered M501 to M513, was followed by 26 WH-2s, numbered M514 to M539. All aircraft were delivered to the ML-KNIL in the standard American colours of the time, with yellow wings, blue fuselage, and marked with Dutch roundels. At the end of 1939, the roundels were replaced by large orange triangles. The aircraft were then camouflaged in two shades of green on top, light grey underneath from 16 August 1940. These bombers were used to defend the Dutch East Indies, some aircraft of 2-VI.G.III were sent to Singapore in December 1941 during two months. In 1936, the Argentinean Army ordered 22 Model 139 WAA, equipped with Wright Cyclone R-1820-G3, and three Focke-Wulf Fw 58B Weihe for training (see kit #FR010). The bombers were registered 501 to 522 and assigned to El Palomar, from April 1938, then to the Regimiento Aéreo 1, on the BAM Coronel Pringles. Aircraft 502, 509, 510, and 522 flew to Rio Grande, Tierra del Fuego, between the end of April and May 11, 1943. Aircraft 508, 518, and 522 flew to Santiago de Chile in September 1943 to take part in the Independence Day celebrations. The bombers served in natural metal marked with roundels and codes on and under the wings and on the fuselage, a large fin flag, and the code on the leading edge of the wings. From October 1943 they were camouflaged in green above and pale blue below, with a small fin flag. In January 1944, the letter B for Bombardero was added before the code. Aircraft B-511 and B-510 were damaged and received new nose sections. The last flight of a 139 WAA took place on July 12, 1954 (B-512). Further development gave the YB-12 and B-12A airframes. The YB-12 also known as Model 139B had 250 or 500 US gallons (950 or 1,890 L) flotation chambers for safety on overwater flights, and two Pratt & Whitney R-1690-11 Hornet radial engines. These 775 hp (578 kW) engines gave similar performance to those on the B-10B (218 mph (351 km/h)), seven built, five still in service in April 1940. The B-12A was production version of the YB-12 with provision for a 365 US gal (1.380 L) fuel tank in the bomb bay, giving the B-12A a combat range of 1,240 mi (2,000 km), 25 built, 23 still in service in April 1940.

Specifications (139 WH-2):

Wingspan 21.49 m, length 13.63 m, wing area 63 m<sup>2</sup>. Engines: two 840 hp Wright Cyclone R-1820-G3. Maximum altitude, 5.182 m. Armament: 1.029 kg of bombs, 3 machine guns.

# Plastic Parts

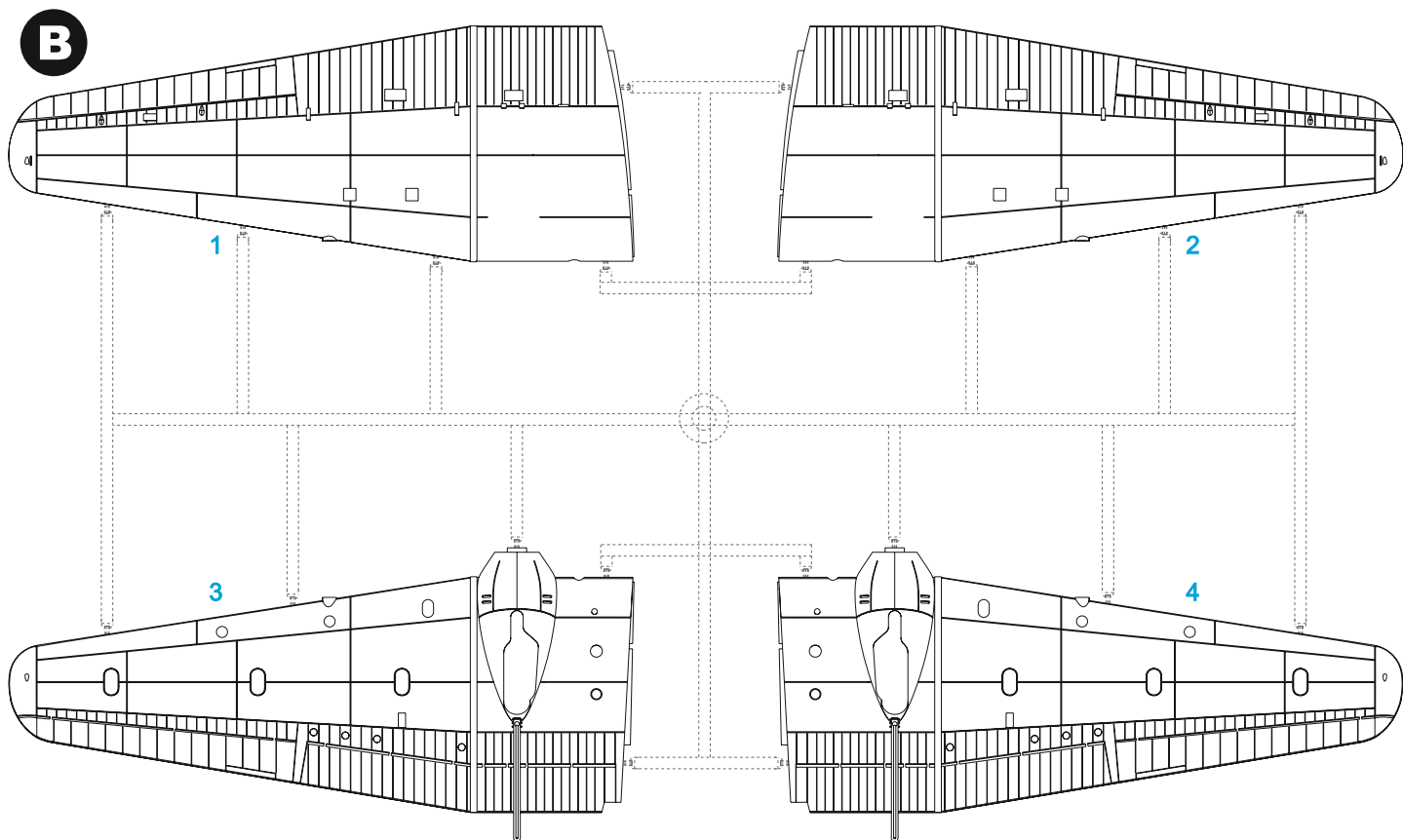
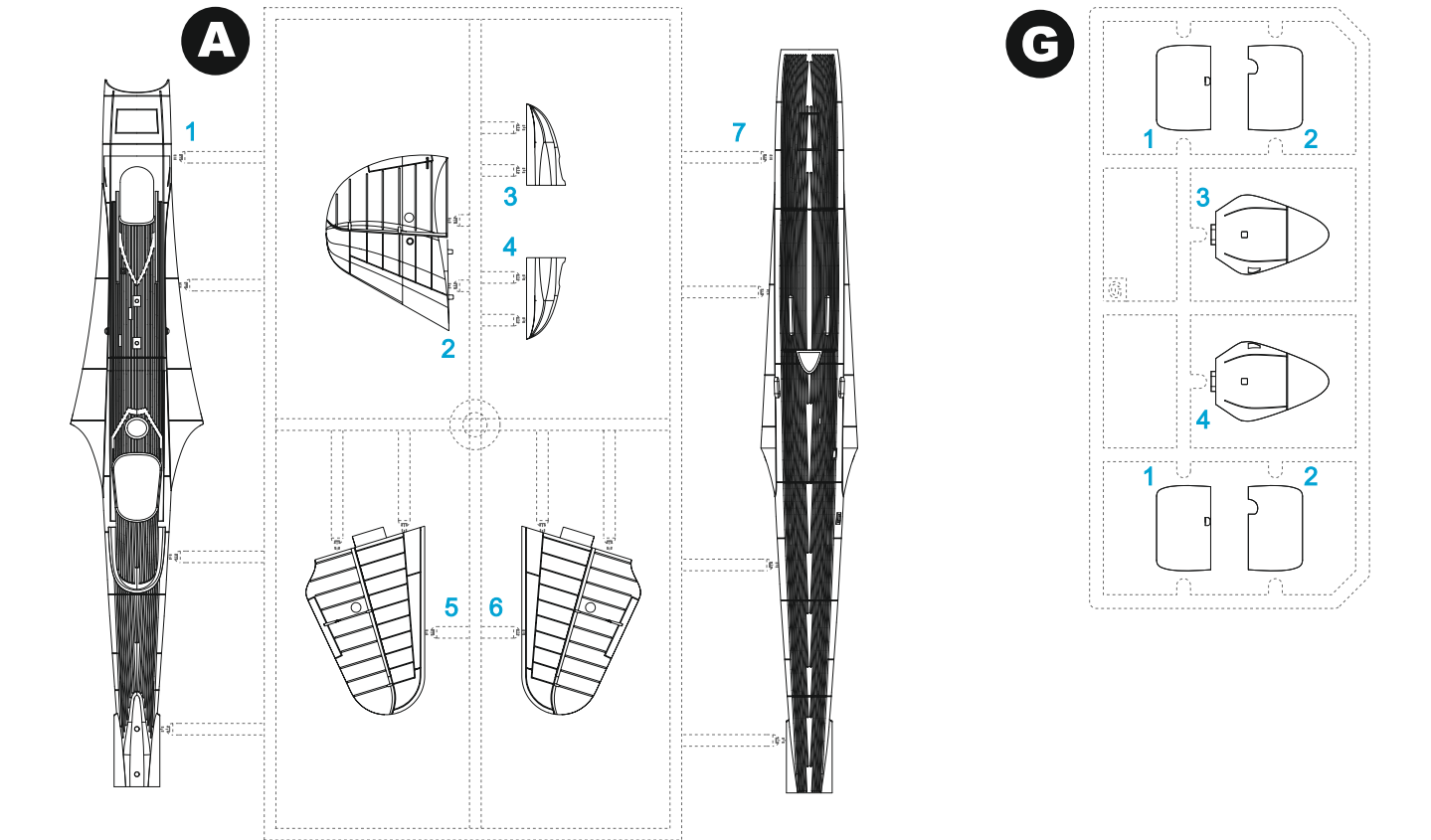

## SYMBOLS



MOŽNOST VOLBY  
OPTIONAL  
NACH BELIEBEN  
OPTION



POUŽIT KYANOAKRYLÁTOVÉ LEPIDLO  
INSTANT CYANOACRYLATE GLUE  
ZYANOAKRYLÁTKLEBER  
COLLE CYANOACRYLAT



OHNOUT  
BEND  
BIEGEN  
COURBER



ZHOTOVIT NOVÉ  
SCRATCH BUILD  
FERTIGSTELLEN  
ACHEVER



ŘEZAT/VRTAT  
CUT OFF/DRILL  
ENTFERNEN  
DETACHER

GSI **A**  
colour code

NATŘÍT  
COLOUR  
FARBEN  
PEINDRE

# Plastic Parts

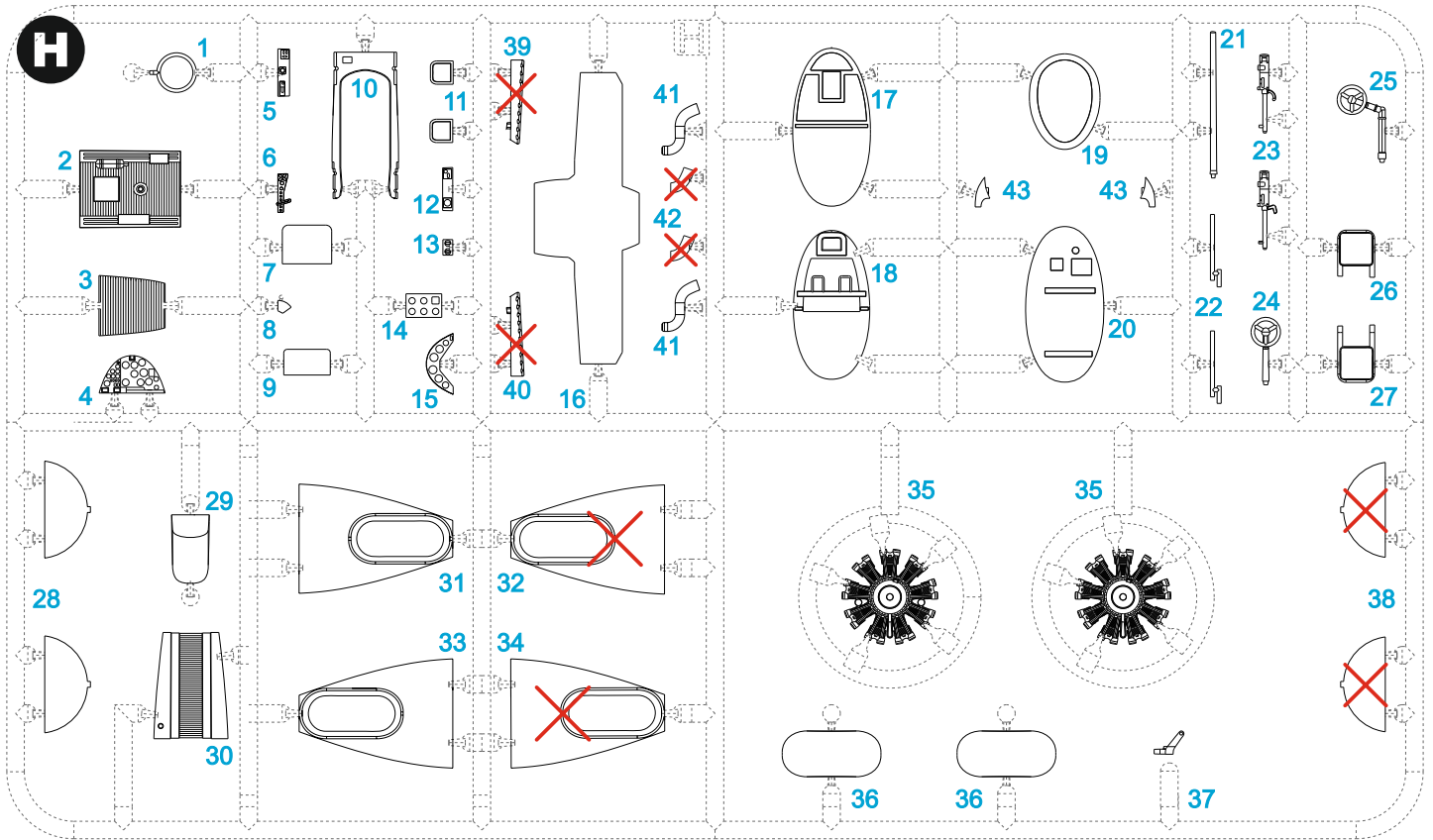

## Clear Parts (CP)

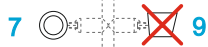
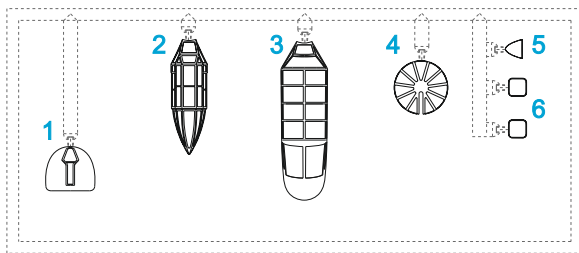

= parts not to be used

## Barvy GUNZE/ GUNZE Colour No.

<b>A</b>	Černá / Black	H12/C33
<b>B</b>	Hliníková / Aluminium	H/C8
<b>C</b>	Bronzová / Bronze Green	H/C340
<b>D</b>	Opálený kov / Burnt Metal	H76/C61
<b>E</b>	Tmavý kov / Dark Metal	H28/C78
<b>F</b>	Čirá červená / Clear Red	H90/C47
<b>G</b>	Čirá zelená / Clear Green	H94/C138
<b>H</b>	Černá pneu / Tire Black	H77/C137
<b>I</b>	Letecká šedá / Aircraft Gray	H57/C73
<b>J</b>	Barva plátna / Sail	H85/C45

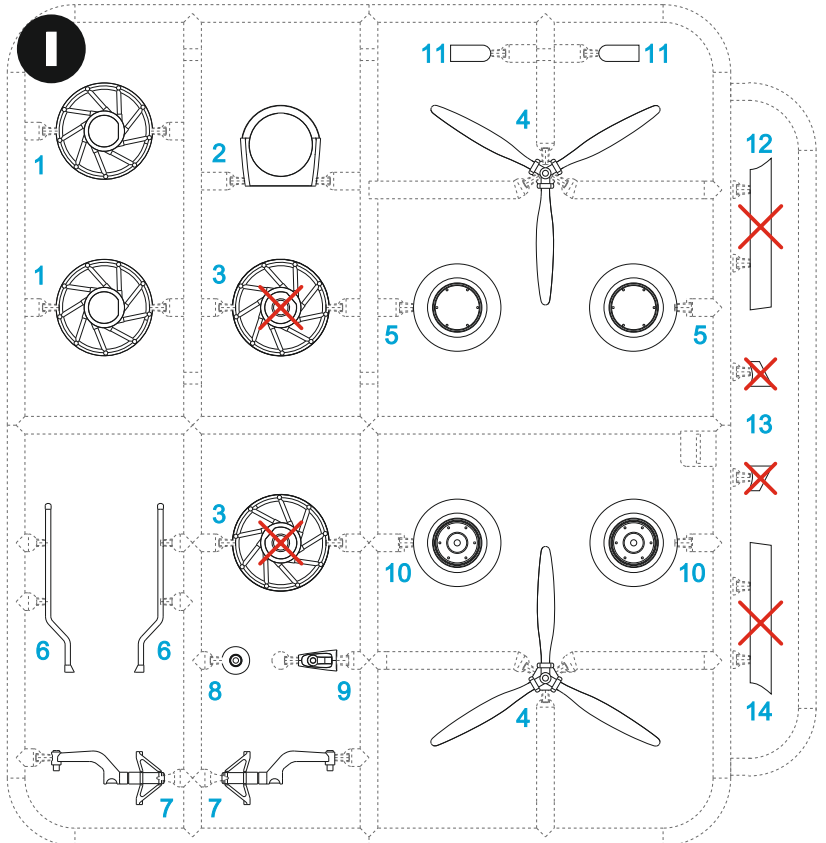

## Photo-Etched Parts (PE)

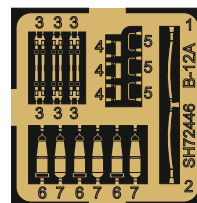

**STEP 1**

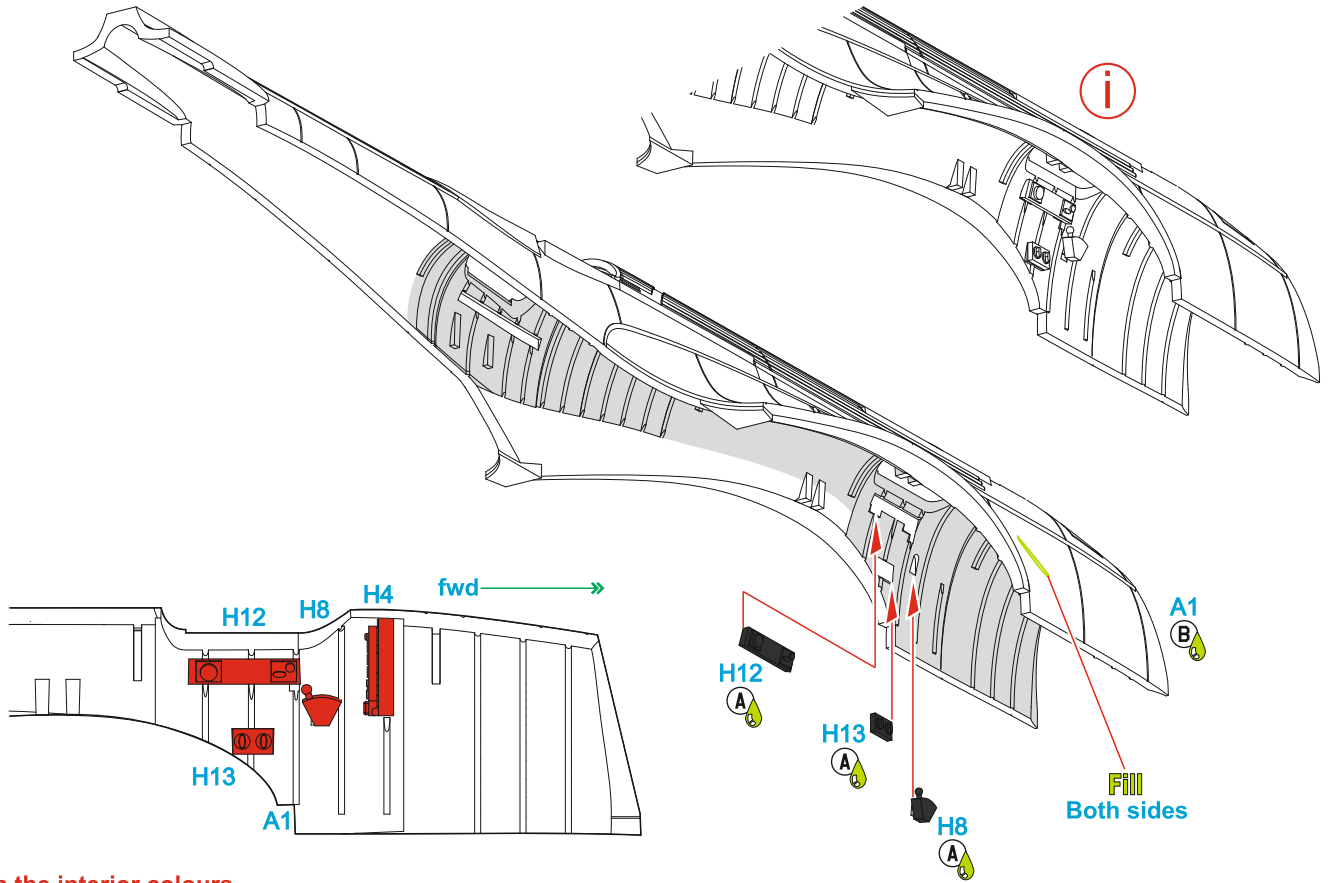

**Note on the interior colours**

Cockpits and turret area, undercarriage bays, legs and engine cowlings of the pre-war B-12A airframes were painted in Aluminium Lacquer. The exceptions were the instrument panels and a few other items which were either in Black, Bronze Green or Zinch Chromate Green as indicated throughout the build steps.

**STEP 2**

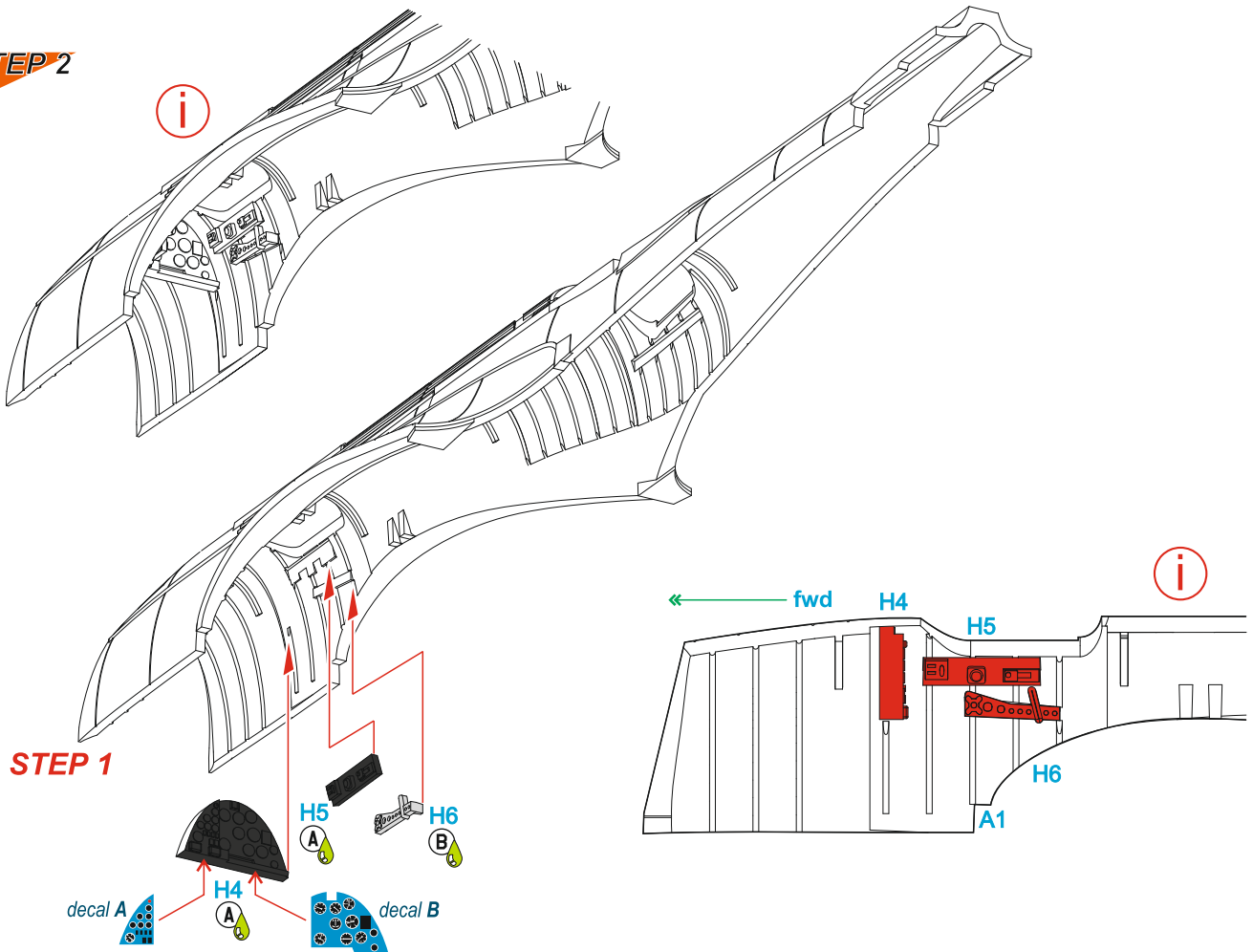



**STEP 3**

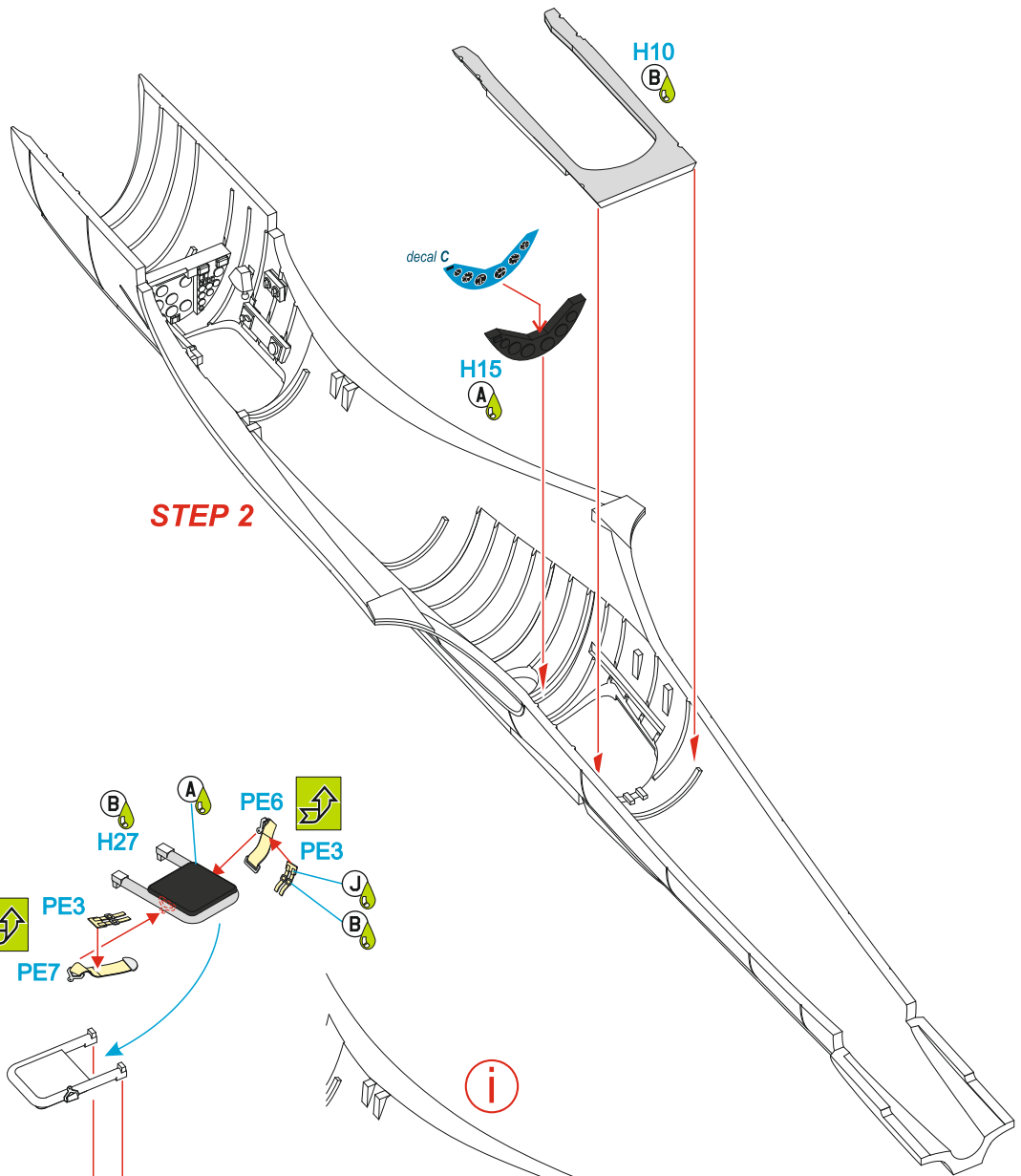

**STEP 4**

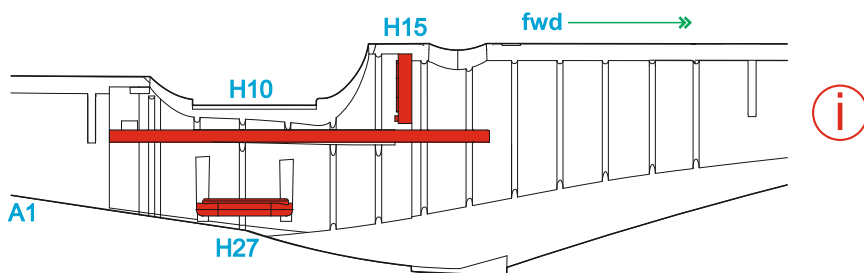
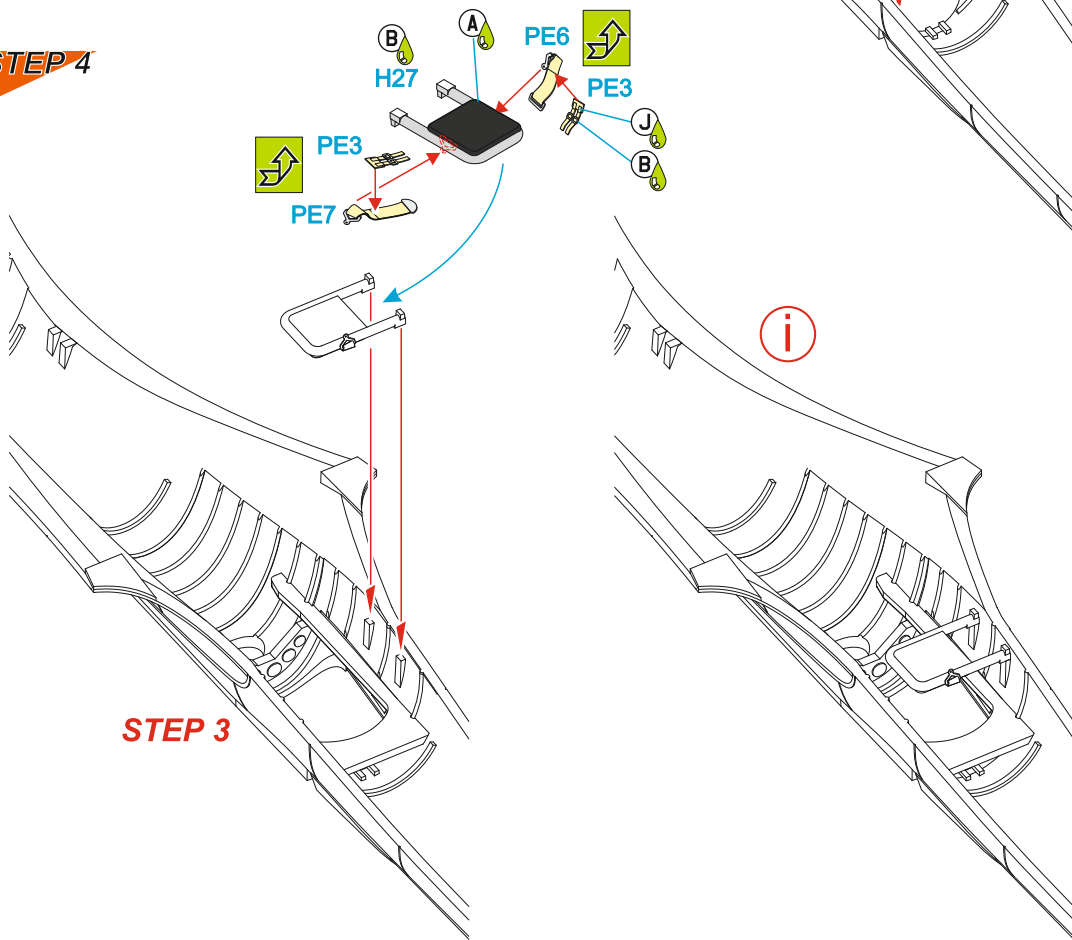

**STEP 5**

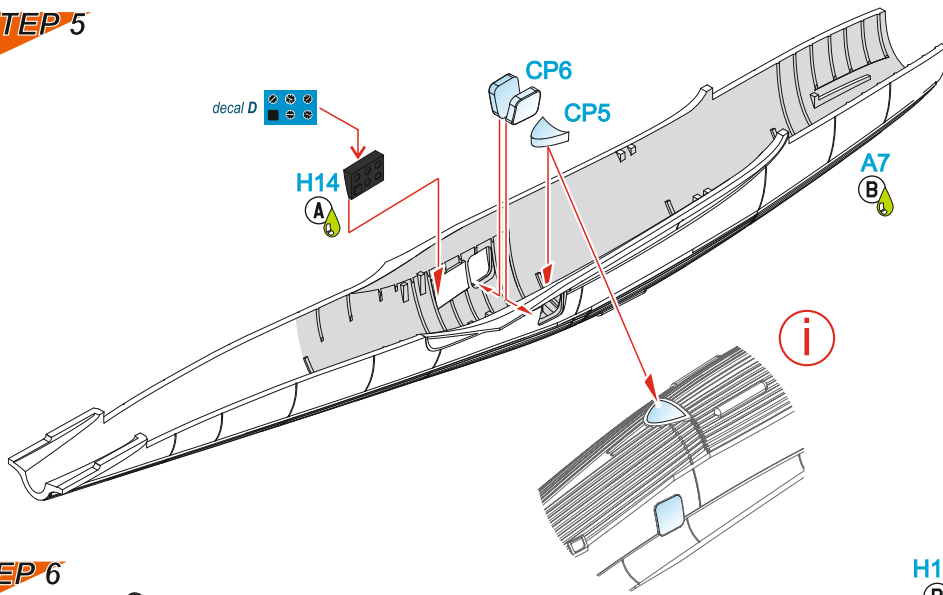

**STEP 6**

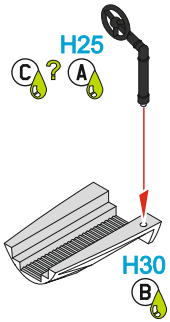

**STEP 7**

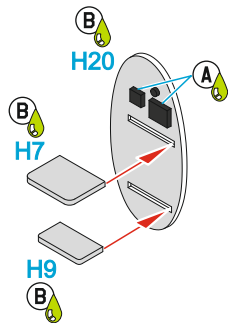

**STEP 7**

**STEP 6**

H19

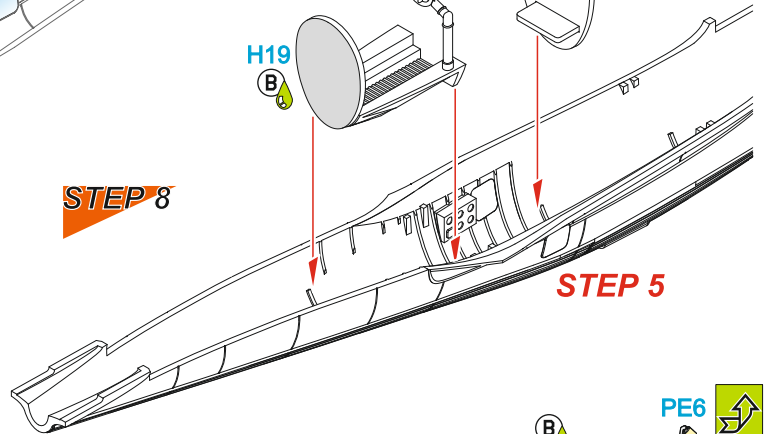

**STEP 8**

**STEP 5**

**STEP 9**

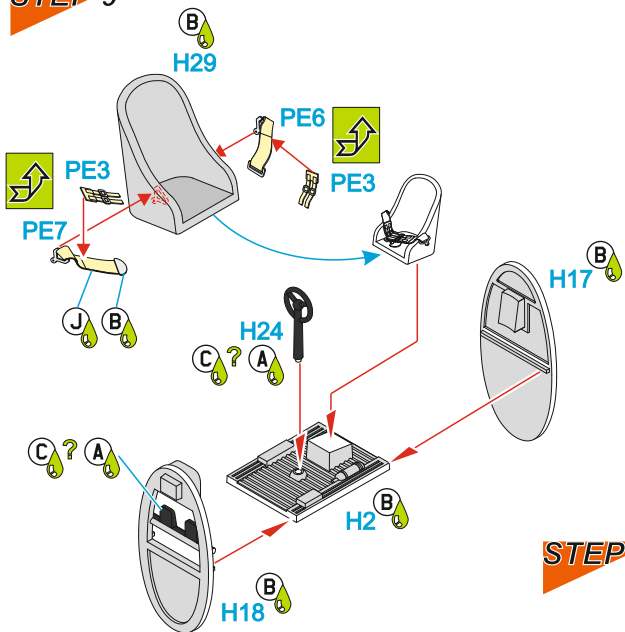

**STEP 10**

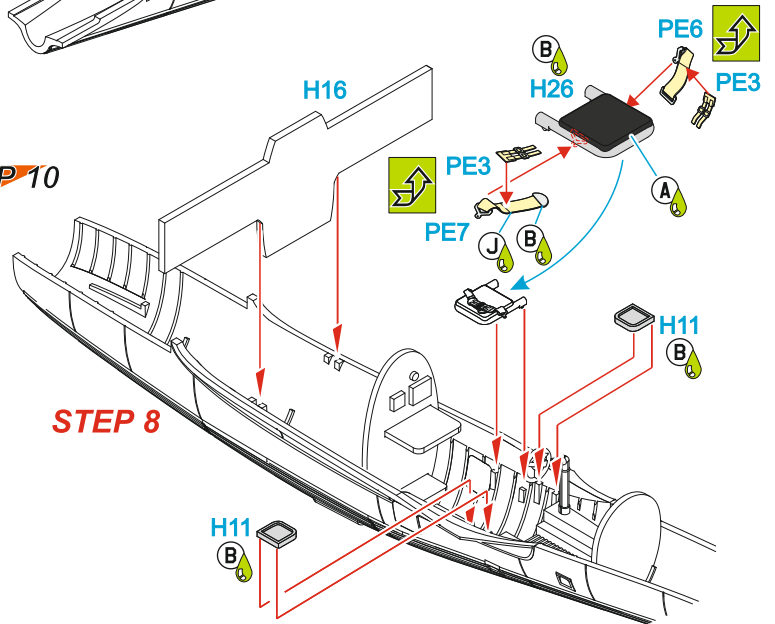

**STEP 8**

**STEP 11**

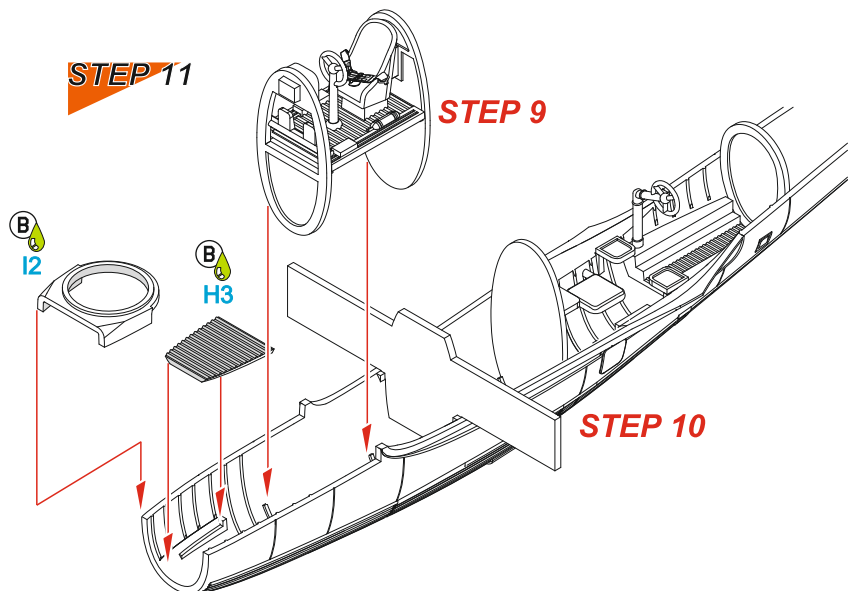

**STEP 9**

**STEP 10**

**STEP 12**

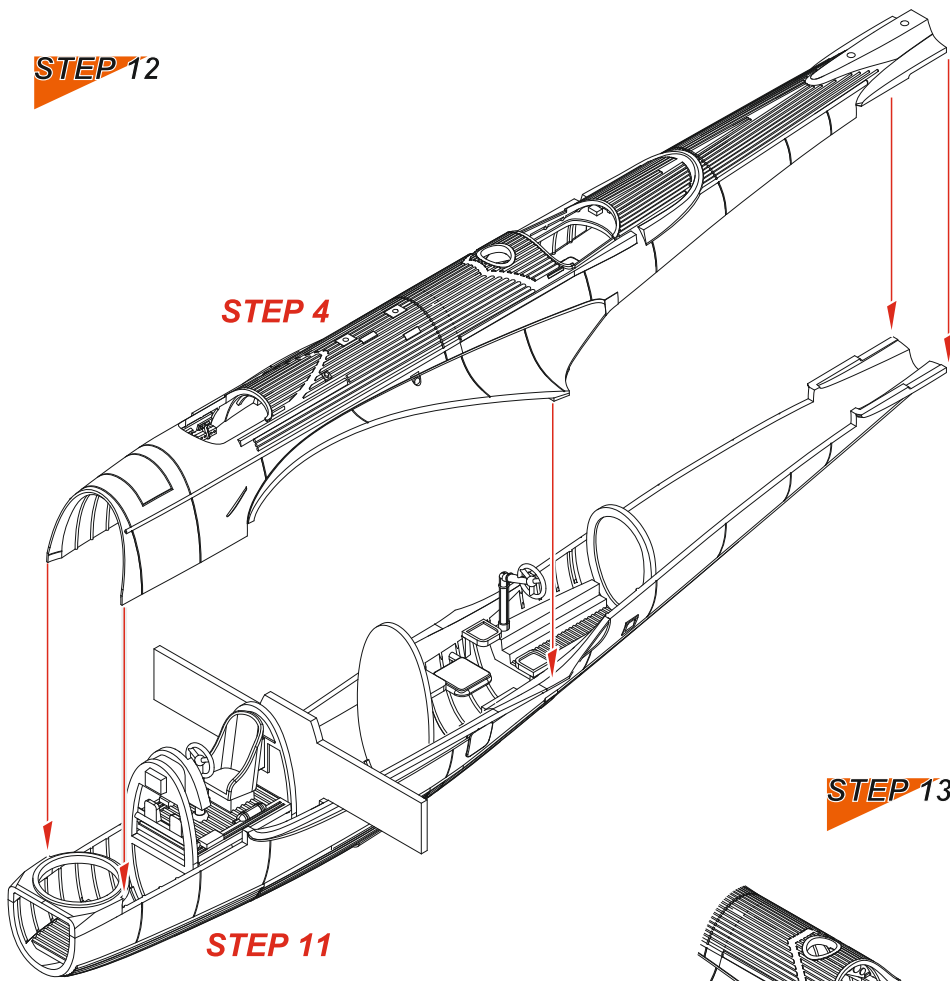

**STEP 13**

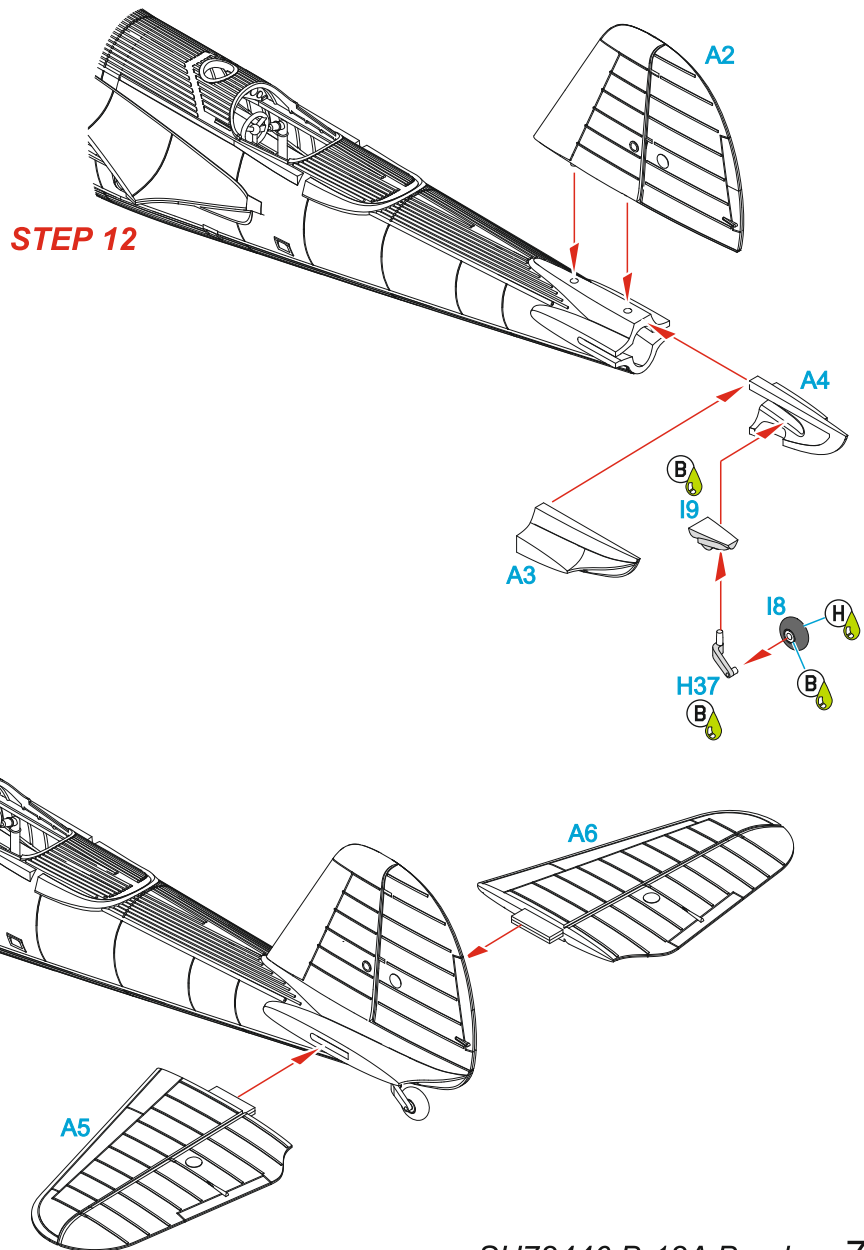

**STEP 14**

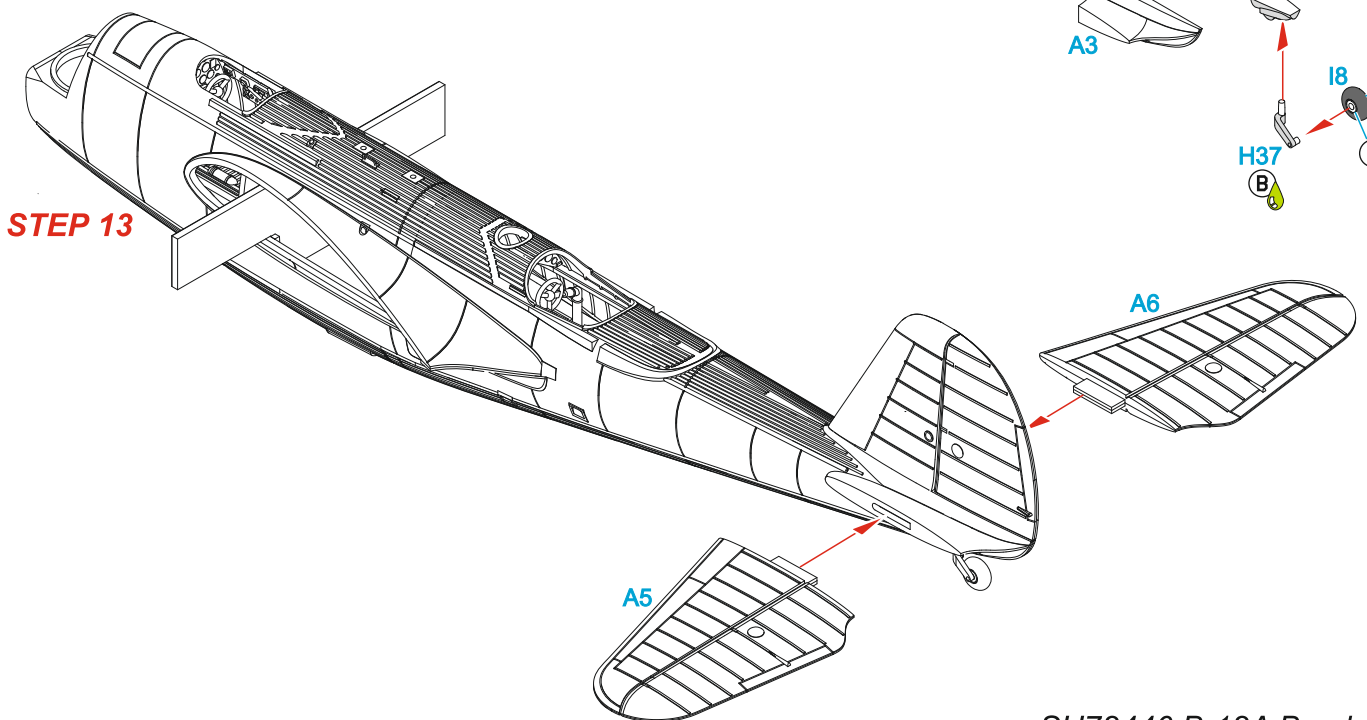

**STEP 15**

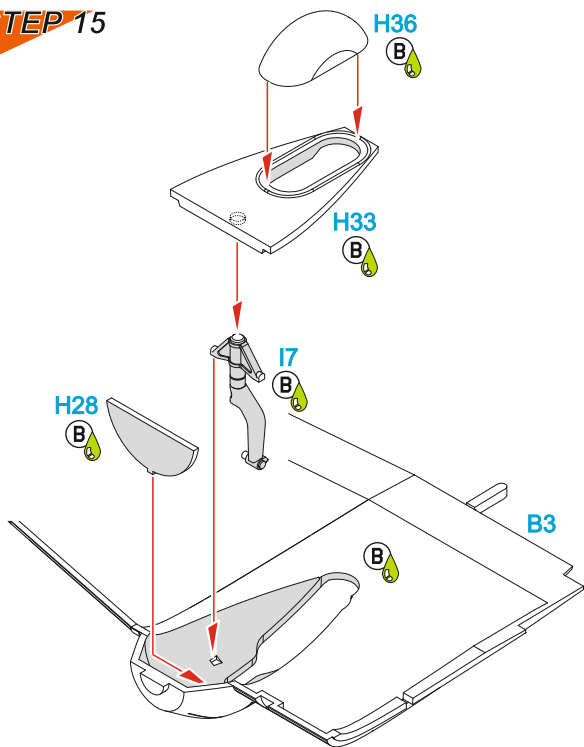

**STEP 16**

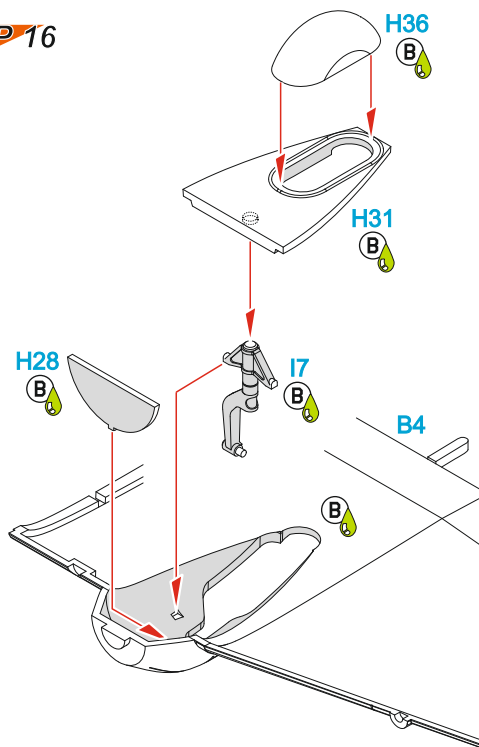

**STEP 17**

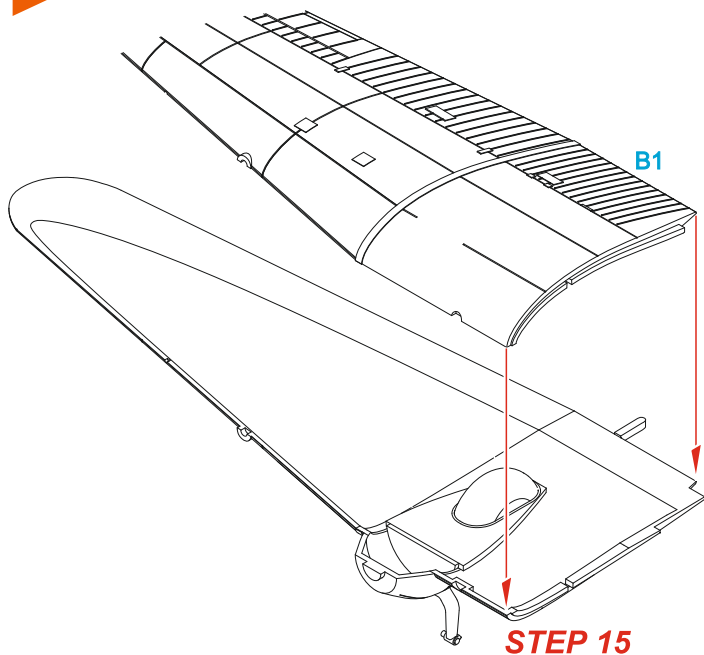

**STEP 18**

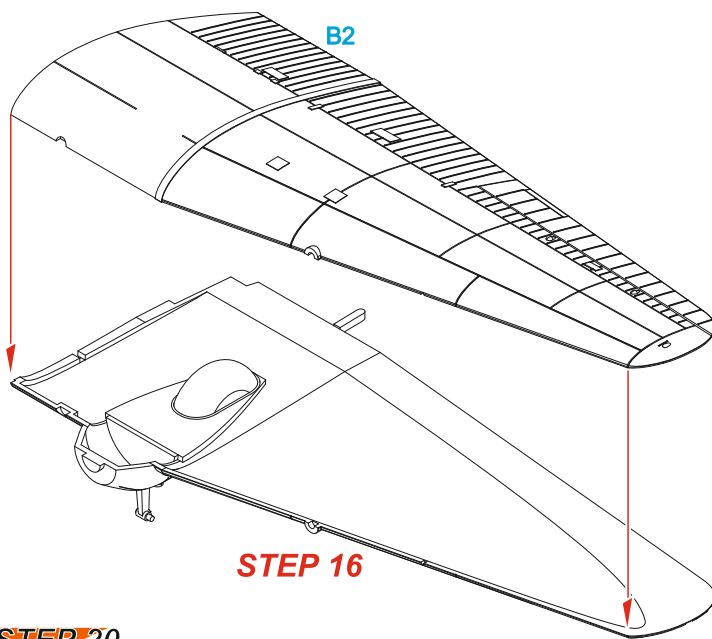

**STEP 19**

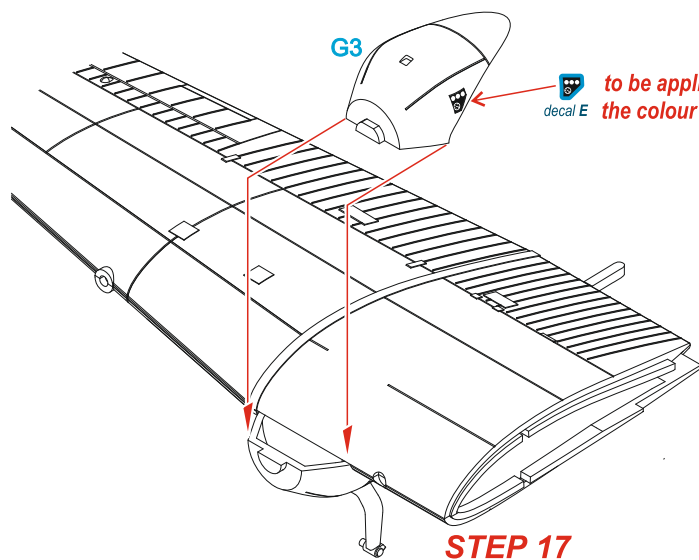

**STEP 20**

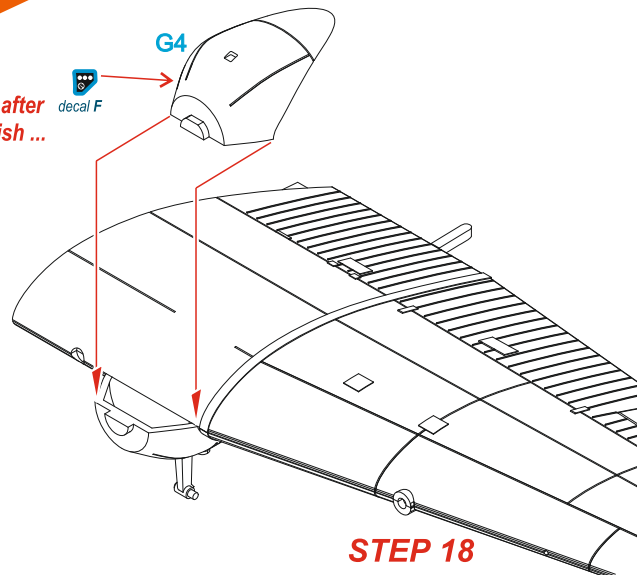

to be applied after the colour finish ...



**STEP 17**

**STEP 18**



**STEP 21**

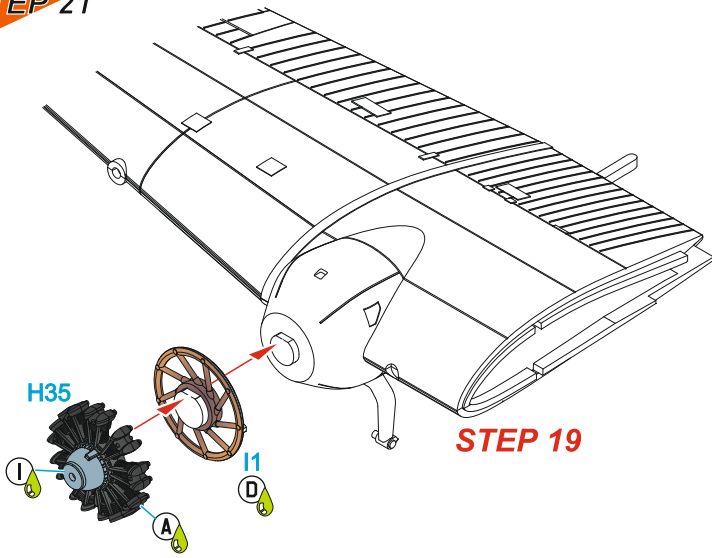

**STEP 19**

**STEP 22**

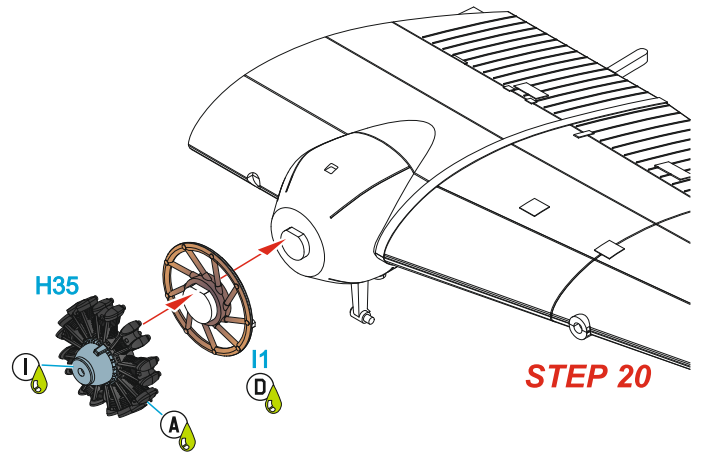

**STEP 20**

**STEP 23**

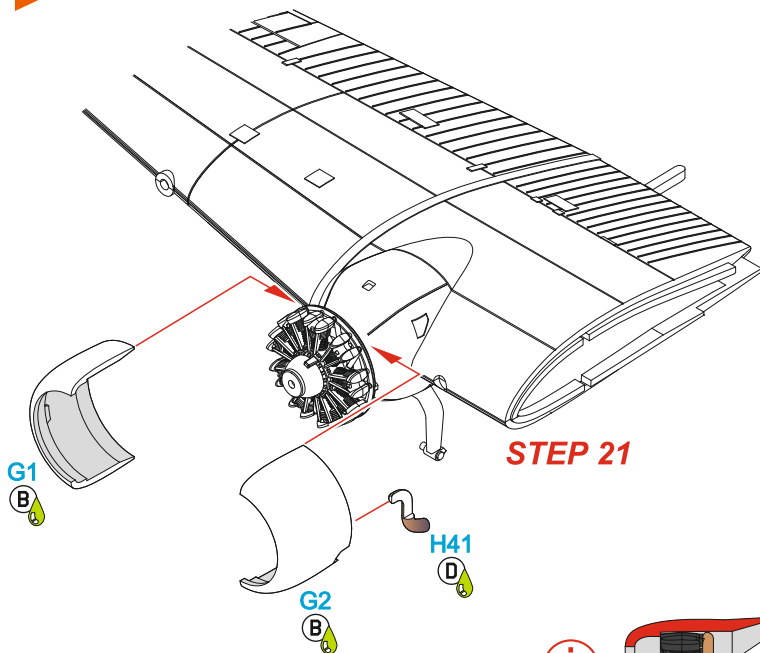

**STEP 21**

**STEP 24**

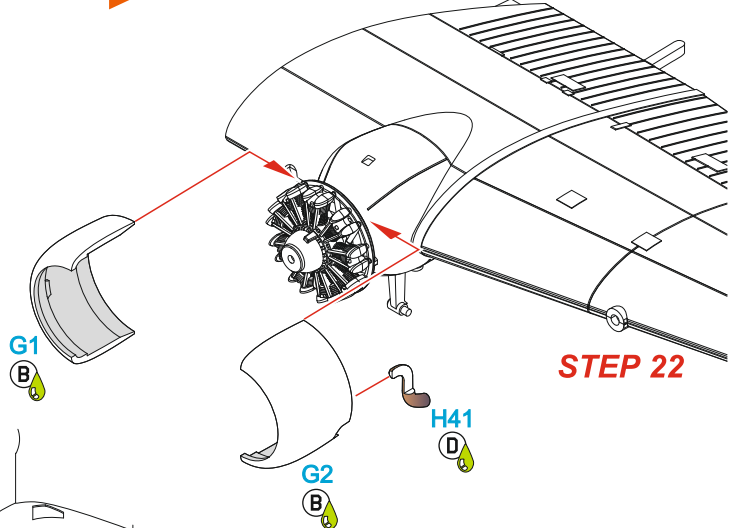

**STEP 22**

**i** detail view of engine and cowling installation

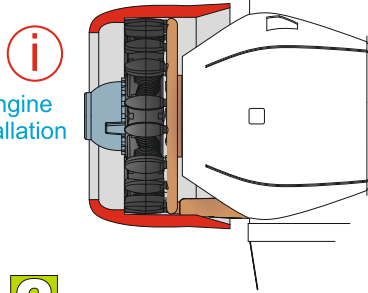

**STEP 25**

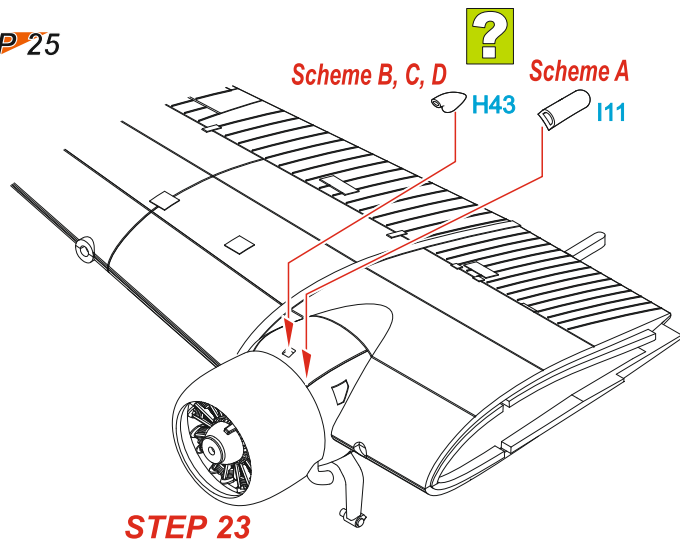

**STEP 23**

**STEP 26**

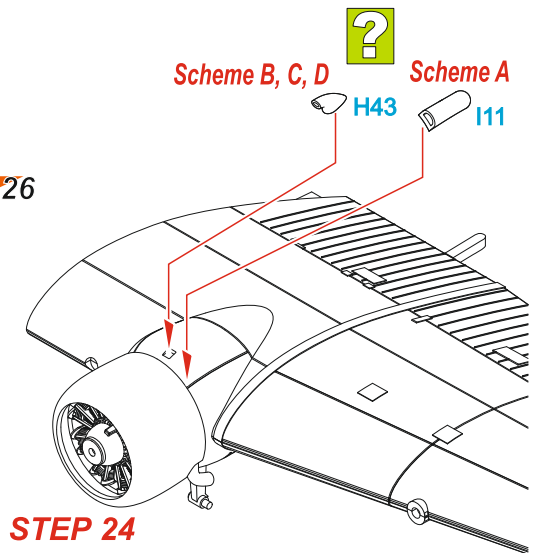

**STEP 24**

**STEP 27**

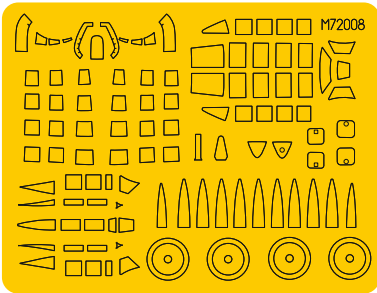
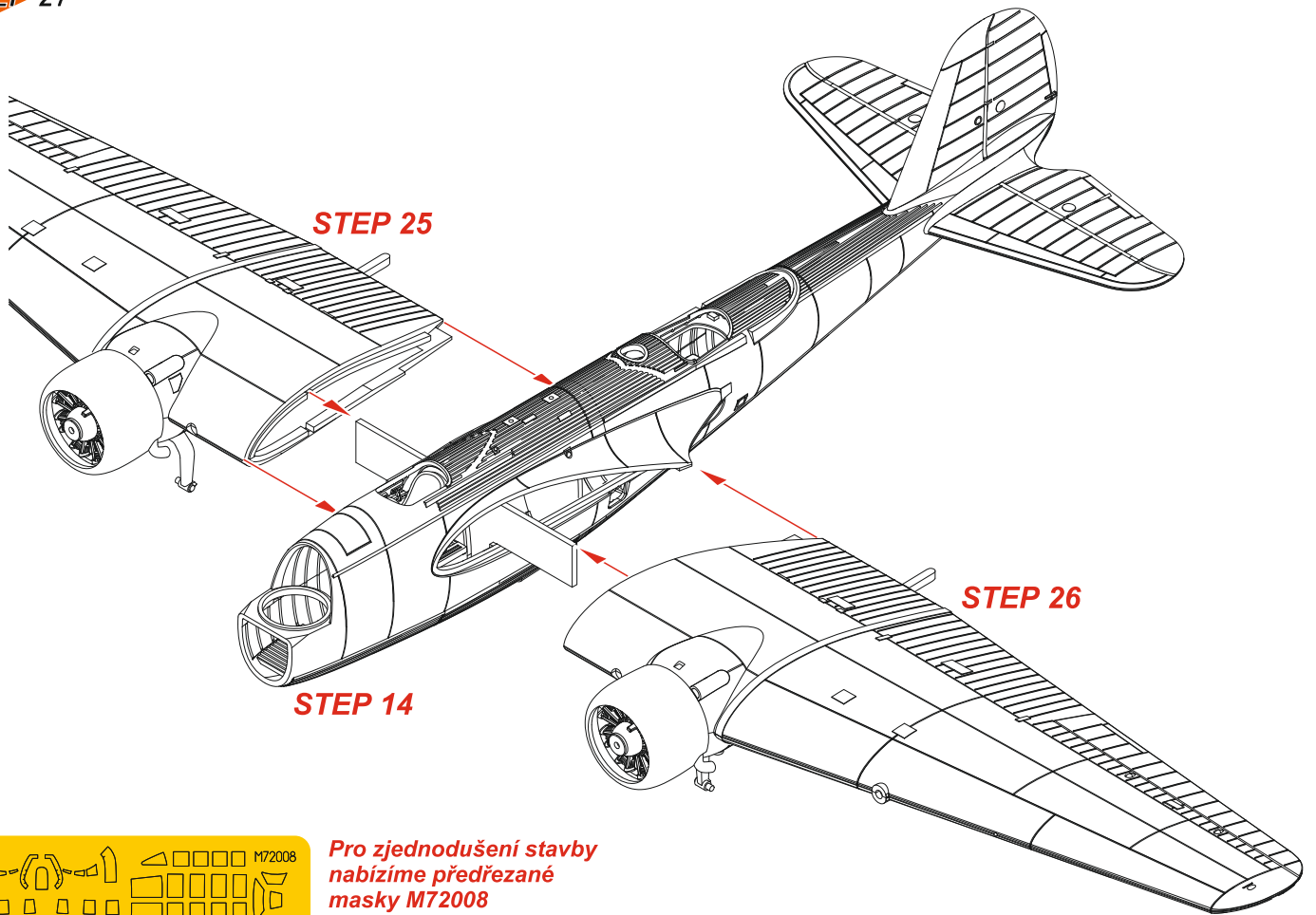

*Pro zjednodušení stavby nabízíme předřezané masky M72008*

*For easier build, we offer pre-cut masks M72008*

**STEP 28**

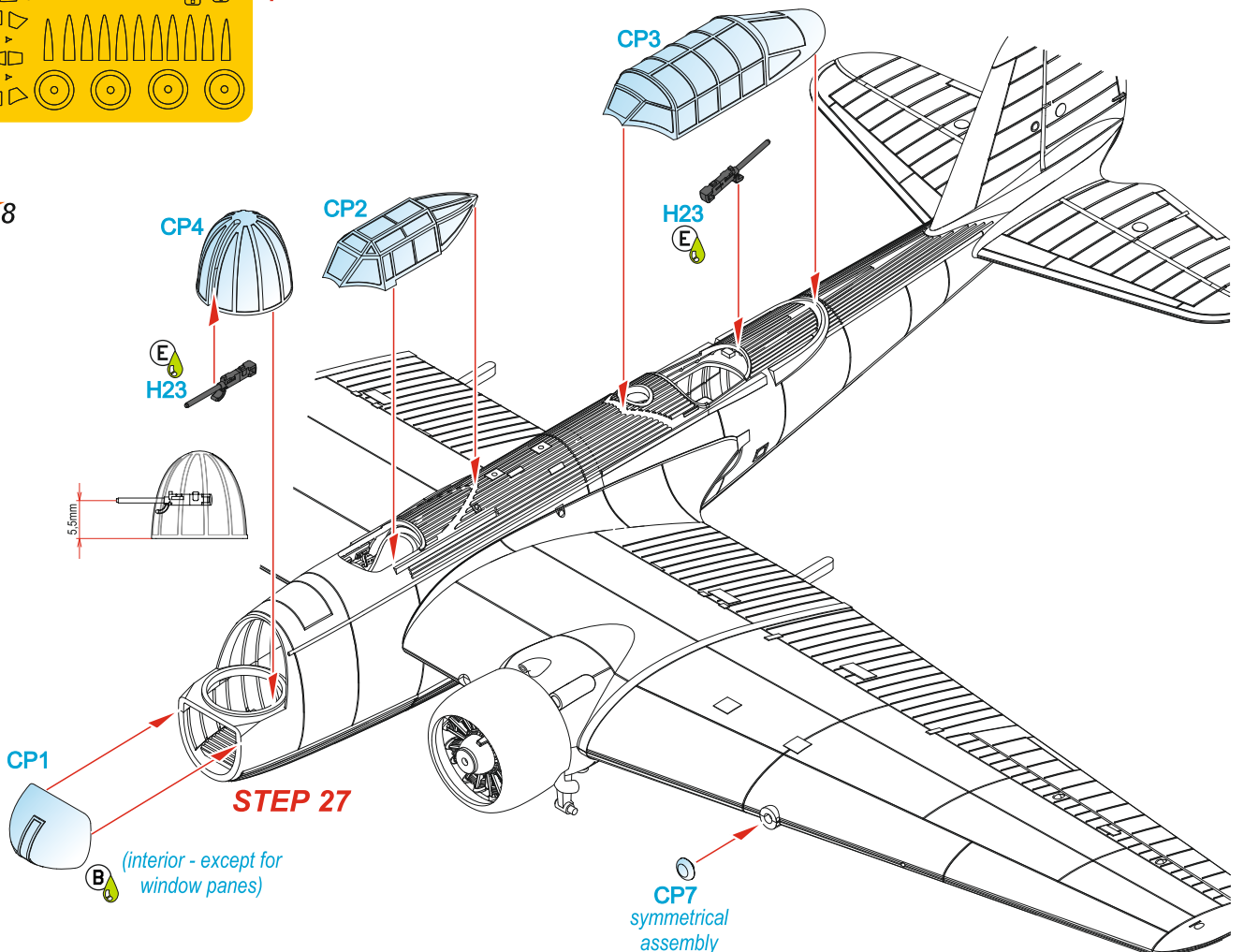

**STEP 29**

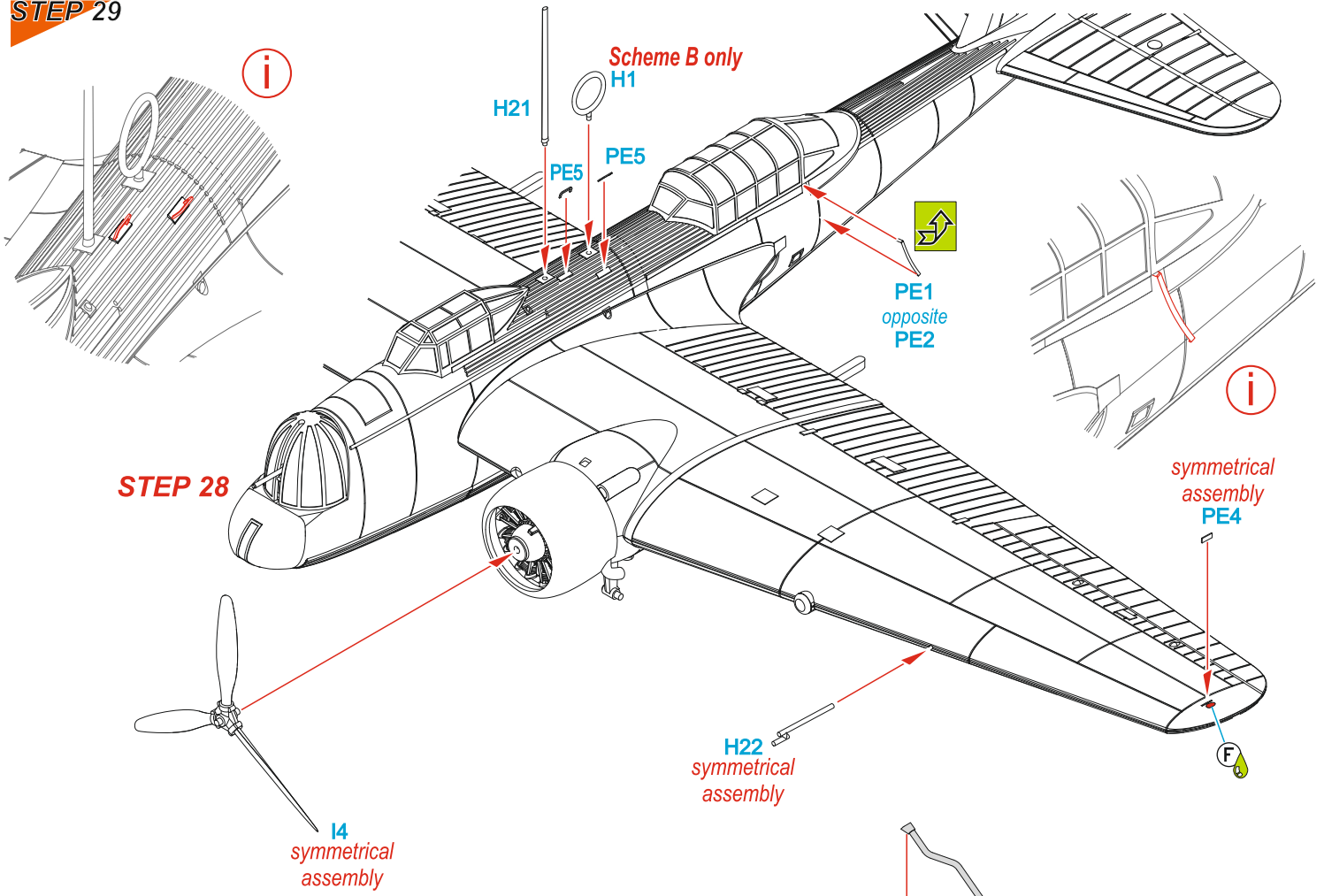

**STEP 30**

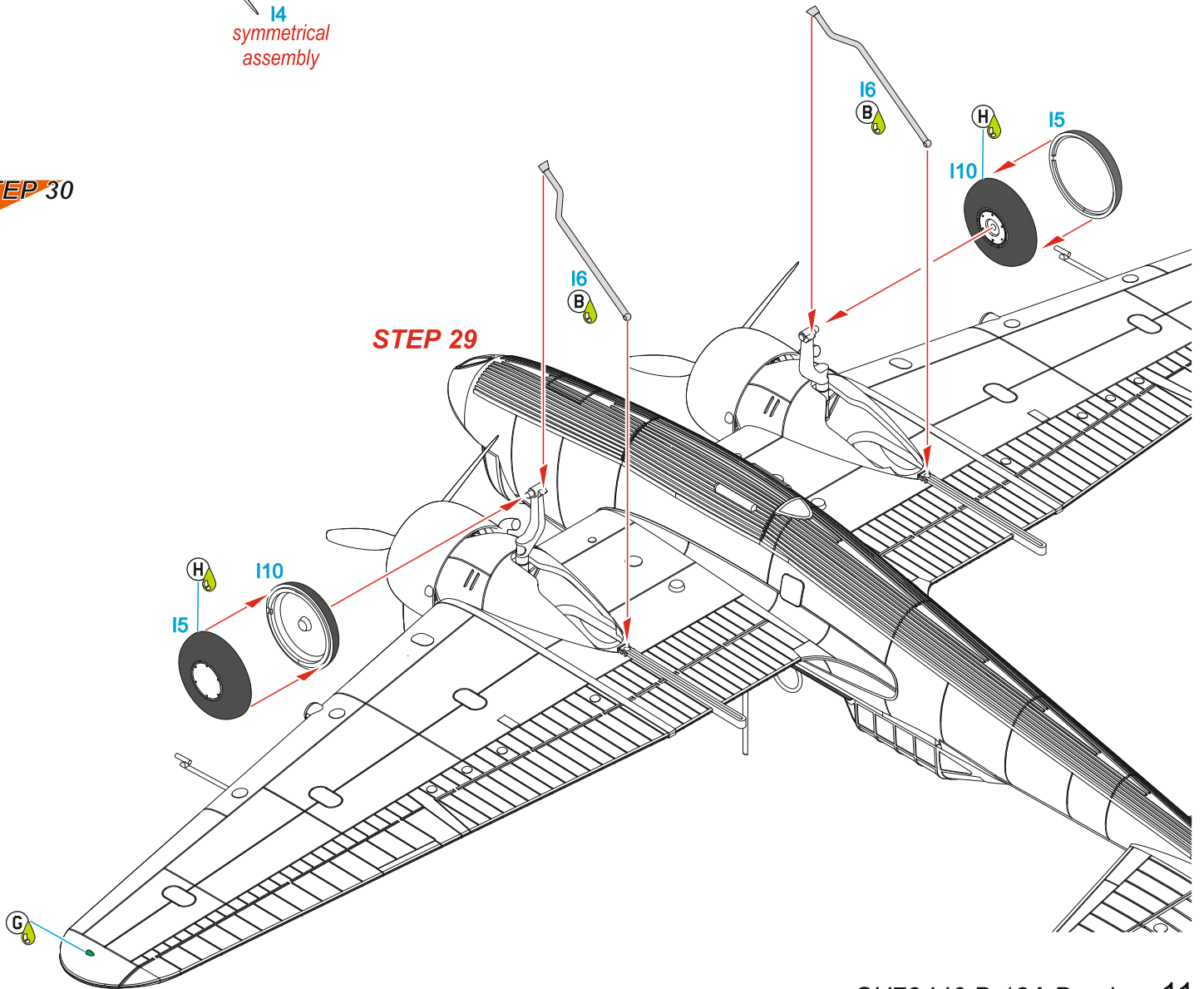







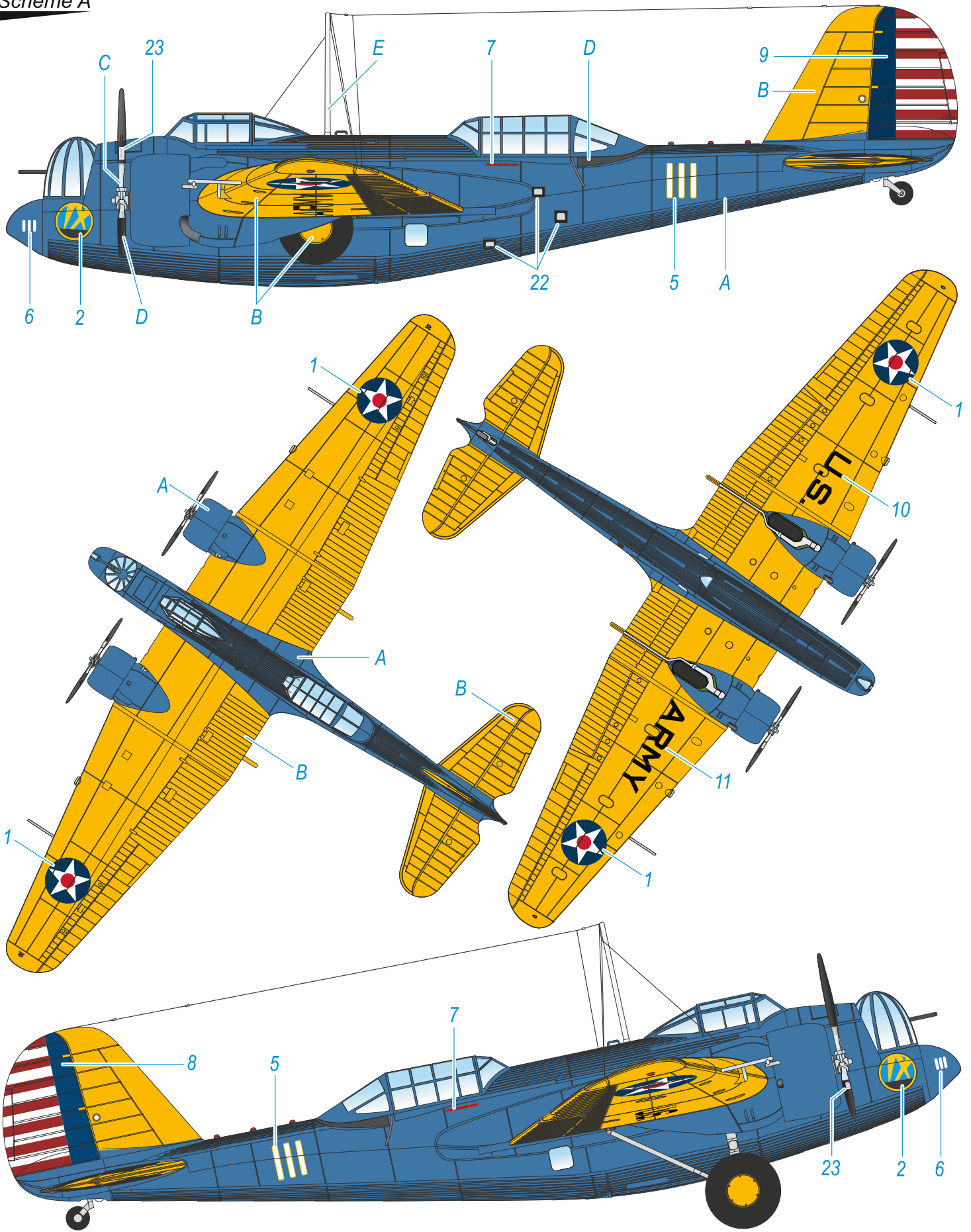

B-12A, No.111, 9th Bombardment Squadron,  
7th Bombardment Group, Kalifornie, USA, 1935.

B-12A, No.111, 9th Bombardment Squadron,  
7th Bombardment Group, California, USA, 1935.

**Scheme A**



- |  |   |   |  |   |
|--|---|---|--|---|
|  <b>A</b> Light Blue 23<br>Světle modrá<br>FS35109 |  <b>B</b> Yellow 4<br>Žlutá<br>FS13415 |  <b>C</b> Natural Metal<br>Přirodní kov<br>H/C08 |  <b>D</b> Black<br>Černá<br>H12/C33 |  <b>E</b> White<br>Bílá<br>H11/C62 |
|--|---|---|--|---|







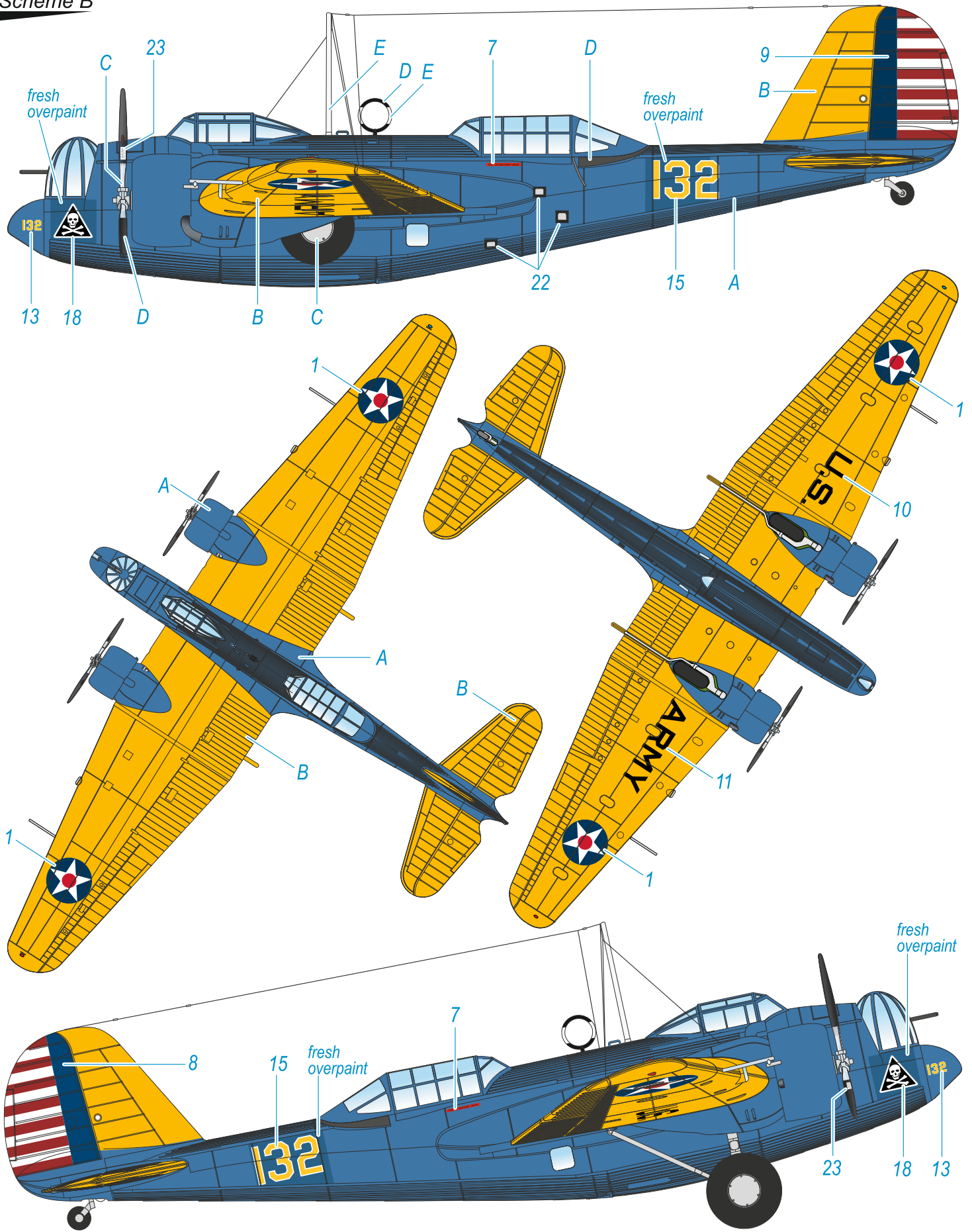

B-12A, No.132, 31th Bombardment Squadron,  
7th Bombardment Group, Kalifornie, USA, 1934.

B-12A, No.132, 31th Bombardment Squadron, 7th  
Bombardment Group, California, USA, 1934.

**Scheme B**



- |  |   |   |  |   |
|--|---|---|--|---|
|  <b>A</b> Light Blue 23<br>Světle modrá<br>FS35109 |  <b>B</b> Yellow 4<br>Žlutá<br>FS13415 |  <b>C</b> Natural Metal<br>Přirodní kov<br>H/C08 |  <b>D</b> Black<br>Černá<br>H12/C33 |  <b>E</b> White<br>Bílá<br>H11/C62 |
|--|---|---|--|---|

B-12A, No.143, 11th Bombardment Squadron,  
7th Bombardment Group, Kalifornie, USA, 1937.

B-12A, No.143, 11th Bombardment Squadron,  
7th Bombardment Group, California, USA, 1937.

**Scheme C**

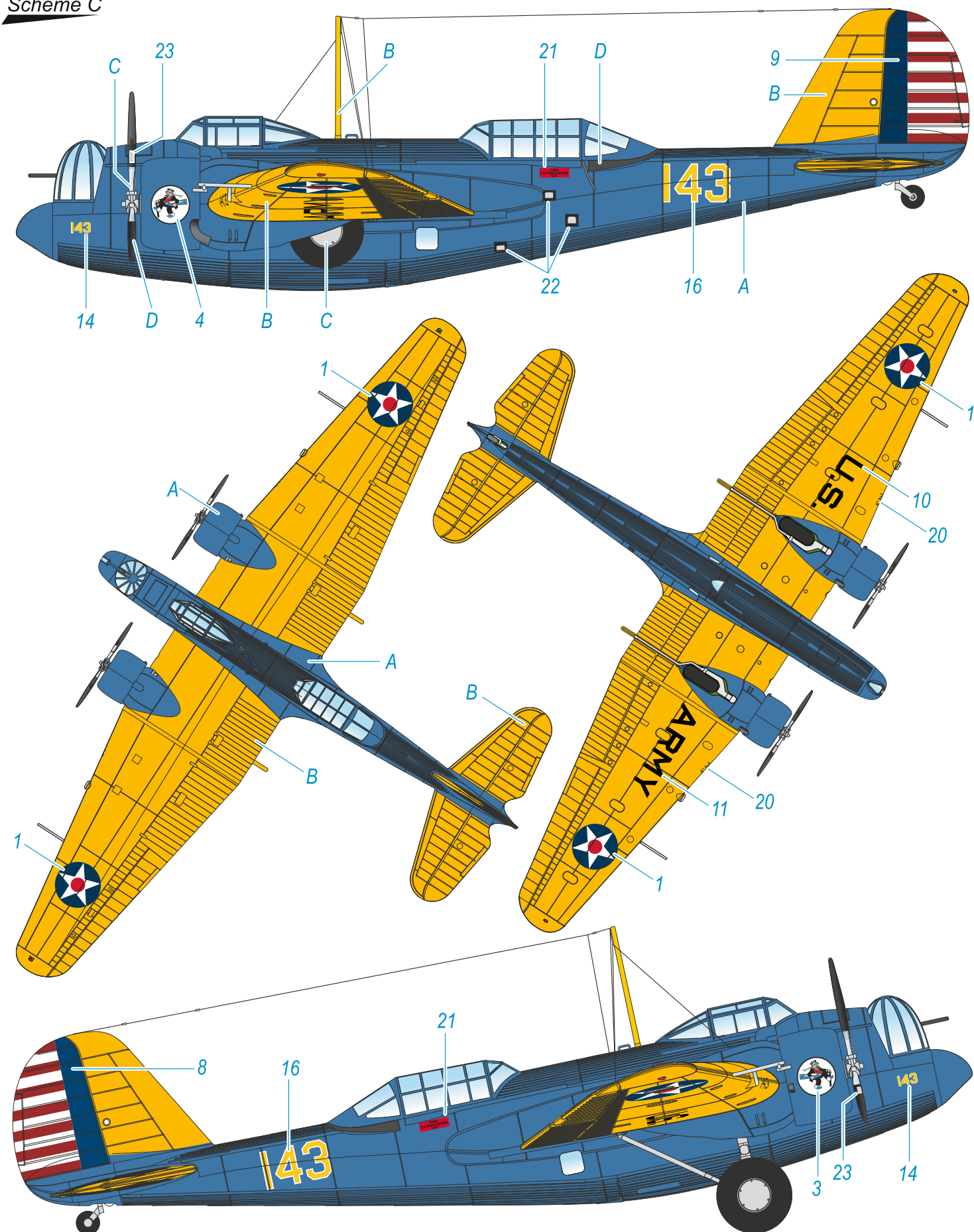

- |   |  |  |   |  |
|---|--|--|---|--|
|  A Light Blue 23<br>Světle modrá<br>FS35109 |  B Yellow 4<br>Žlutá<br>FS13415 |  C Natural Metal<br>Přírodní kov<br>H/C08 |  D Black<br>Černá<br>H12/C33 |  E White<br>Bílá<br>H11/C62 |
|---|--|--|---|--|



**Scheme D**

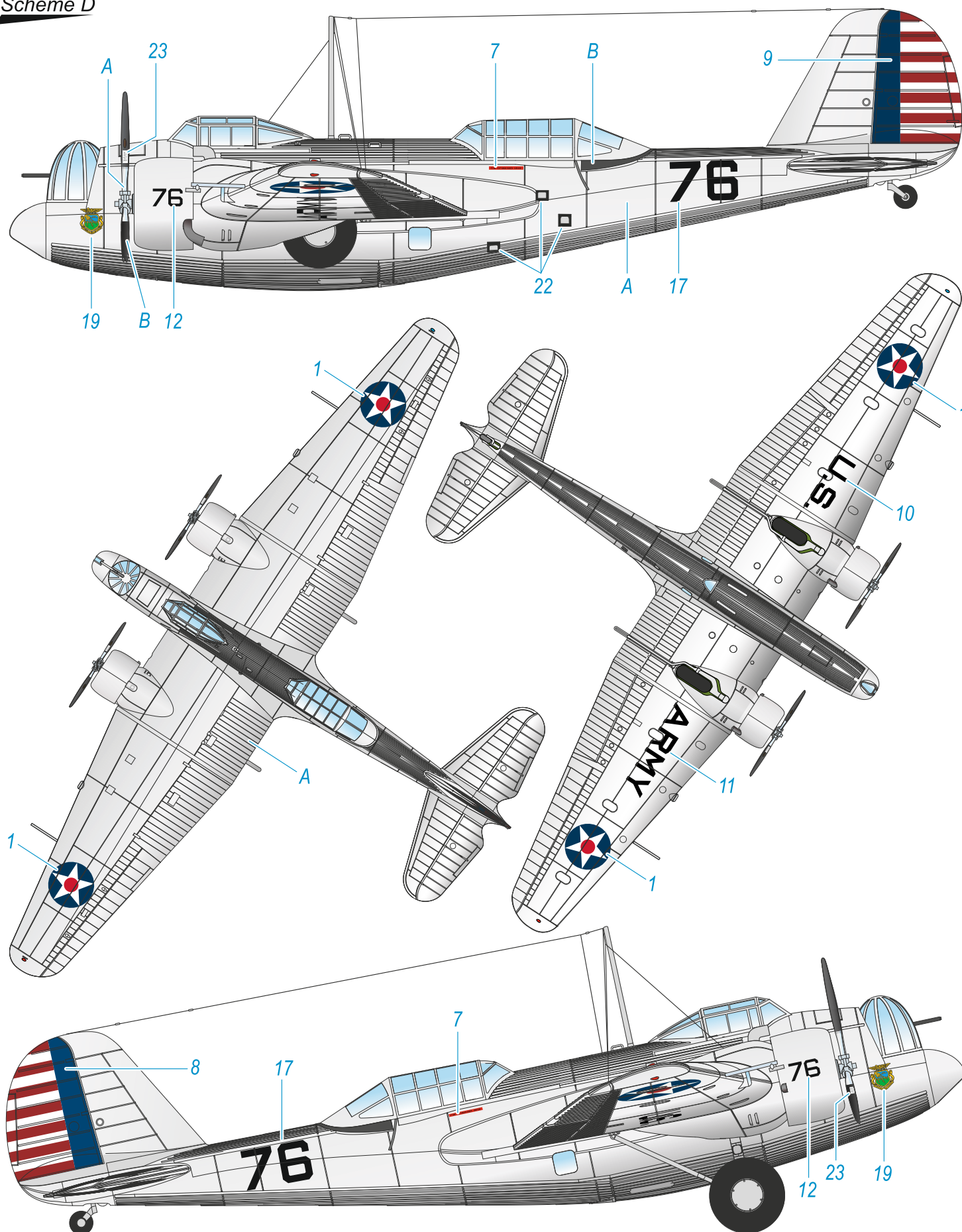

A Natural Metal  
Přirodní kov  
H/C08

B Black  
Černá  
H12/C33





SH72230 B-18B Bolo 'ASW Version'



SH72303 SB2A-4 Buccaneer 'US Marines Bomber'



SH72329 Delta 1D/E US Transport plane