

**CAC CA-9 Wirraway
'In training and combat'**

CZ - Historie

V roce 1936 byla založena z popudu australské vlády letecká a motorářská firma Commonwealth Aircraft Corporation Pty, Ltd. Jasně vystávalo nebezpečí dalšího světového konfliktu a hrozilo, že při odříznutí od zásobovacích tras by nebyl možný dovoz letadel. Samostatnost tak měla zajistit výroba vlastních nebo licenčních letadel. Šéfkonstruktérem se stal L. Wackett. Prvním typem byl na základě licence amerického NA-33 (předchůdce AT-Texanu) vyvinutý cvičný a bitevní A-20. Licence byla zakoupena v červnu 1937. Zakoupení licence vyvolalo bouři nevole v britském parlamentu, podle kterého měla Austrálie dát přednost některé britské konstrukci. Austrálie neustoupila a tak 27. března 1938 byl na továrním letišti Fisherman's Bend zalétán prototyp A20-3. Konstrukce NA-33 byla upravena a zesílena, aby A-20 mohl sloužit nejen ve cvičné, ale i bitevní roli. Také vybavení bylo australské. Stroj dostal bojové jméno Wirraway. Na základě prototypu byla vyráběna úvodní série CA-1. Část letounů je vyráběna jako cvičná, část ozbrojená. Vzhledem k vypuknutí války v Evropě jsou objednány další série CA-3 a CA-5. Stroje jsou postupně vylepšovány. Nakonec jedna výrobní hala produkuje cvičné a druhá hala bojové Wirrawaye. Postupně jsou vyráběny další série označené CA-7, 8, 9, a 16. RAAF své Wirrawaye používalo k výcviku, ale přidělilo je také k celkem devíti bojovým squadronám. První Wirrawaye od 24. Sq. se dostaly do bojů s Japonci při obraně Rabaulu již v lednu 1942. Další jednotky zasáhly do bojů v Malajsku. Po ústupu spojenců z Malajska a Východní Indie Wirrawaye bránily Darwin a byly nasazeny na Nové Guineji. Zde se také Wirrawaye nejvíce proslavily jako bitevní letouny blízké podpory a průzkumné stroje. Jejich účinnost byla taková, že jejich podporu požadovaly nejen australské, ale i americké jednotky. Od roku 1943 jsou Wirrawaye stále častěji přesunovány k výcviku a do bojů jsou nasazovány stíhací Boomerangy. Ale v rámci výcviku se Wirrawaye podílejí na vyčišťovacích operacích na ostrovech severně od Austrálie. Konec války zastavil jejich výrobu. RAAF je ale provozovala ještě dlouho po válce, stejně jako Royal Australian Navy. Po válce byla také část Wirrawayů prodána civilním uživatelům a používána k nejrůznějším úkolům, od létající ambulance až po práškování a hašení požárů.

EN - History

By the impulse from Australian government the Commonwealth Aircraft Corporation Pty, Ltd. aircraft and engine company was founded in 1936. The danger of new World conflict was obvious and the threat of supply routes being cut off would signify that no aircraft could have been imported anymore. The production of domestic designs or license built aircraft could have ensured the independence. The Chief designer became L. Wackett. The first type to be produced was training and ground support A-20 Wirraway developed using license built US NA-33 (Texan predecessor). The license was purchased in June 1937. This led to big displeasure in British Parliament according to which Australia should have preferred some British design. Australian government insisted and on March 27, 1938 the prototype A20-3 took off from the company's airfield Fisherman's Bend. The design of NA-33 was modified and strengthened so that A20 could serve in both trainer and ground support roles. The equipment was of Australian provenience, too. The aircraft was named Wirraway. The initial series CA-1 was produced based on the prototype. Part of the aircraft was produced as trainer the other was equipped with armament. Due to the beginning of the war in Europe further production versions CA-3 and CA-5 were ordered. The aircraft were gradually modified. Eventually, one production plant served for training aircraft and the other for combat Wirraways. Subsequent versions CA-7, 8, 9 and 16 were produced. RAAF used Wirraways mainly for training but also assigned them to nine combat squadrons. The first Wirraways to enter the war were 24. Squadron machines in January 1942 during the defense of Rabaul against Japanese invasion. Other units participated in Malaya and East India fights. Wirraways defended Darwin and were deployed to New Guinea where they gained its greatest fame as ground support and reconnaissance machines. Their effectiveness is best described by the fact that their support was requested not only by Australian but also by US units. From 1943 the Wirraways started to be relocated to training units since new Boomerang fighters started to be assigned to combat units. Even as a part of the training Wirraways participated in clearing the grounds on island north from Australia. Even that with the end of the hostilities the production stopped RAAF and Royal Australian Navy used them long time afterwards. Also, several machines were sold to civil users that used them for various purposes from flying ambulance to aerial spraying and fire bomber.

Technical Data:

Wingspan: 13.11 m, Length: 8.27 m, Max. Speed at sea level / at 1,520 m: 328 / 352 km/h, Service Ceiling: 7,017 m, Range: 1,152 km.

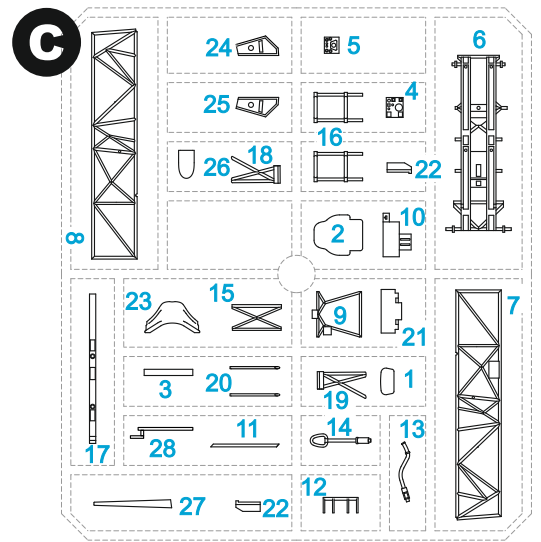
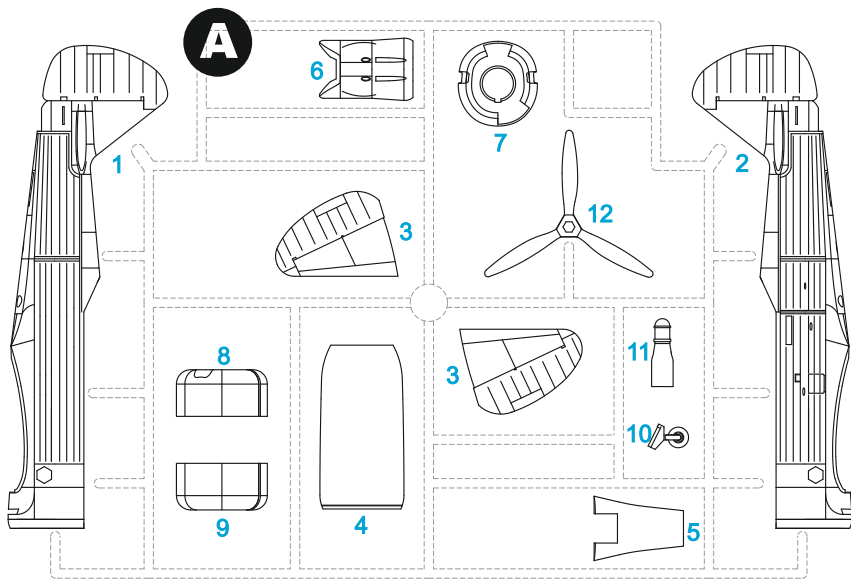

Clear Parts (CP)

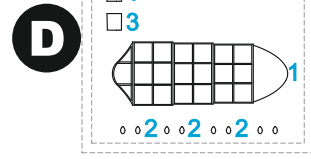
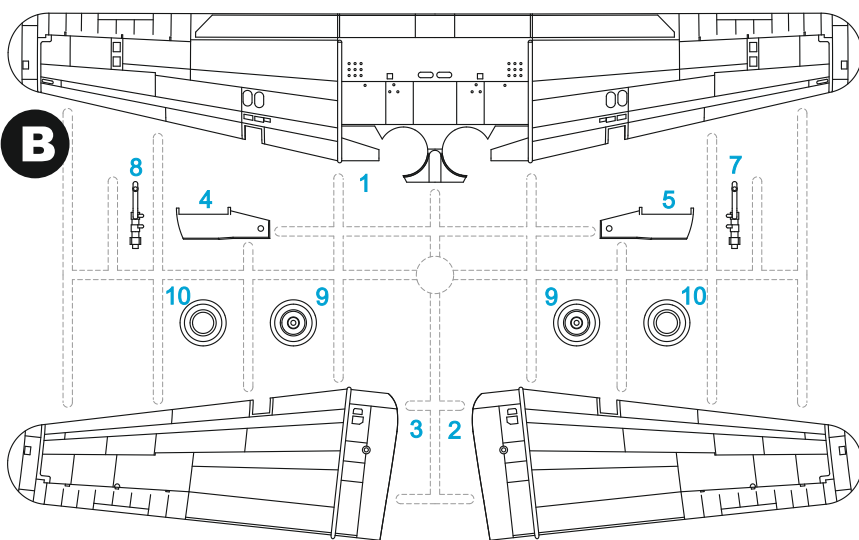

Film Parts (FP)



Photo-Etched Parts (PP)

PUR Parts (F)

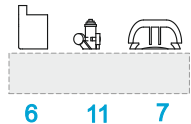
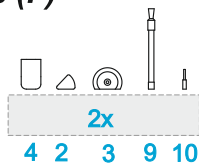
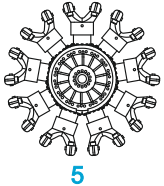
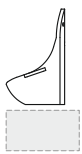

3D Printed part ®



Barvy GUNZE/ GUNZE Colour No.

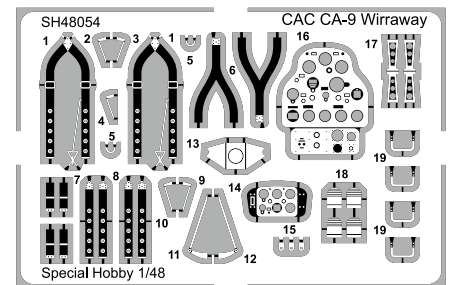

A	Lesklá bílá / GLOSS WHITE	H1/C1
B	Matná černá / MATT BLACK	H12/C33
C	Stříbrná / SILVER	H8/C8
D	Opálený kov / BURNT IRON	H76/C61
E	Plátno / SAIL	H93/C50
F	Kovová černá / METAL BLACK	H28/C78
G	Lak červený / CLEAR RED	H85/C45
H	Barva pneu / TIRE BLACK	H77/C137
I	Listová zelená / FOLIAGE GREEN	H302/C302
J	Šedozelená / GREY GREEN	C364
K	Nebesky modrá / SKY BLUE	H314/C314
L	Zemité hnědá / EARTH BROWN	H72/C22 90% + H47/C41 10%

SYMBOLS

? MOŽNOST VOLBY
OPTIONAL
NACH BELIEBEN
OPTION

Water drop POUŽIT KYANOAKRYLÁTOVÉ LEPIDLO
INSTANT CYANOACRYLATE GLUE
ZYANOAKRYLÁTKLEBER
ADHÉSIF CYANOACRYLAT

Curved arrow OHNOUT
BEND
BIEGEN
COURBER

Hand icon ZHOTOVIT NOVÉ
SCRATCH BUILD
FERTIGSTELLEN
ACHEVER

Scissors icon ODŘÍZNOUT/VRTAT
CUT OFF/DRILL
ABSCHNEIDEN/BOHREN
DETACHER

GSI A NATŘÍT
COLOUR
FARBEN
PEINDRE
colours code

1

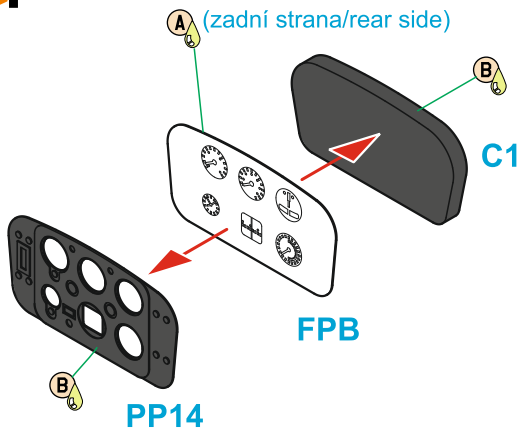

2

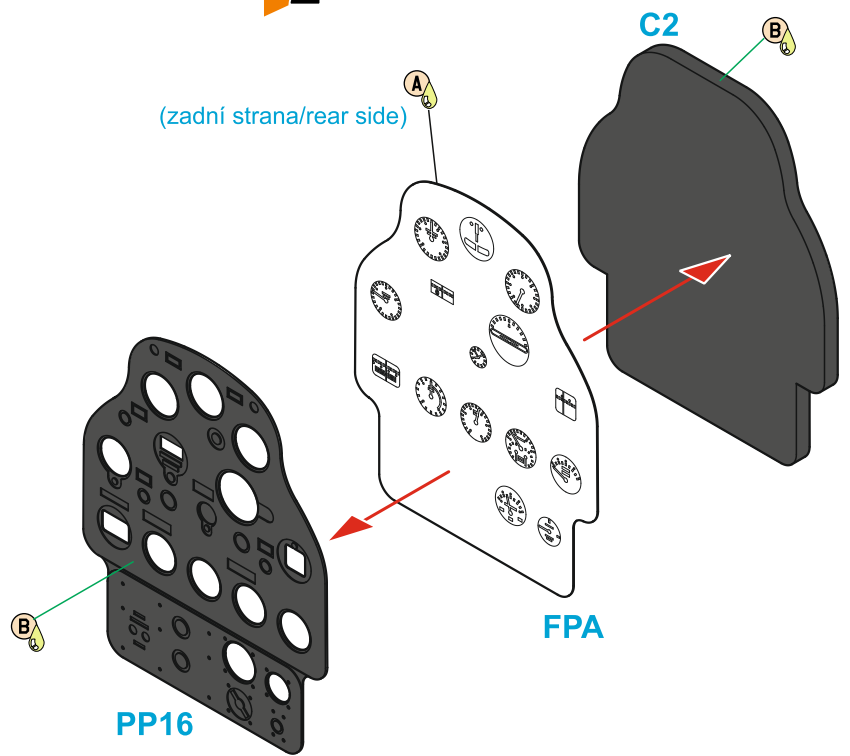

3

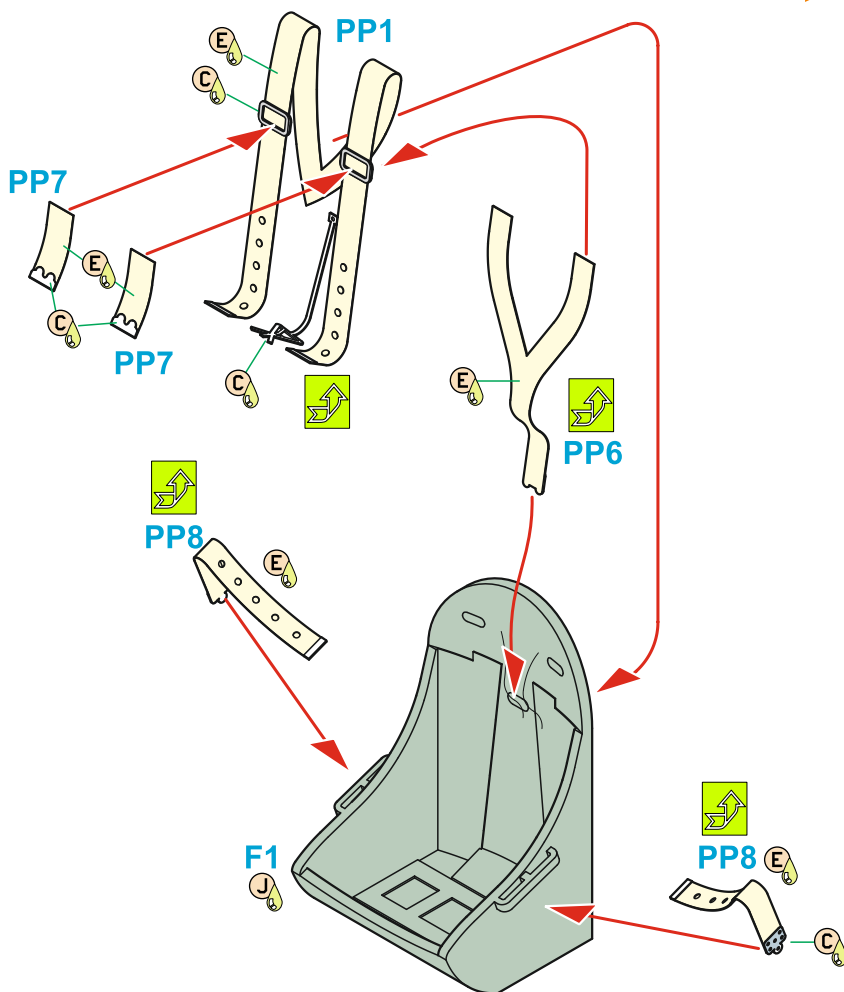

4

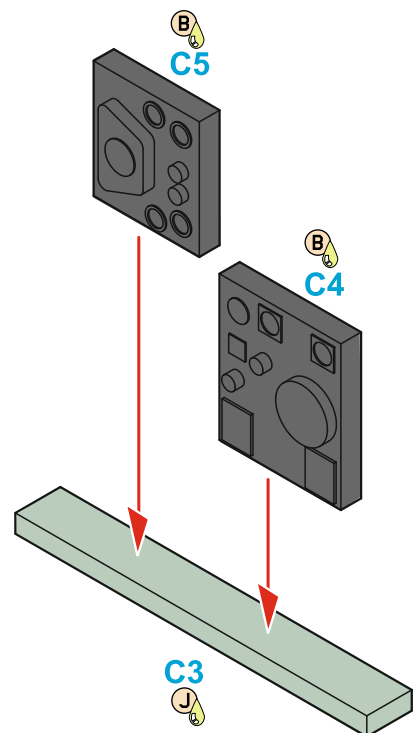

3

5

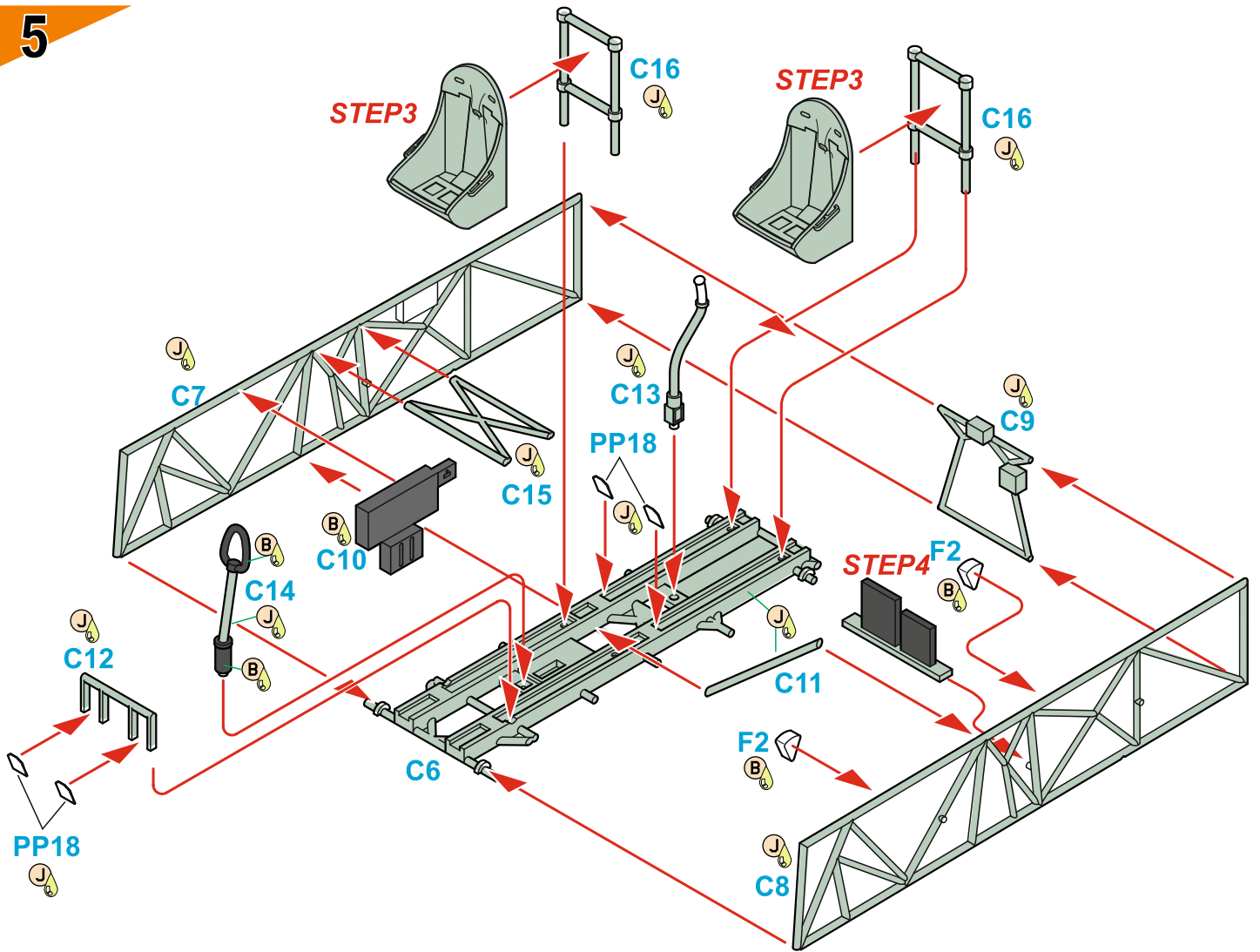

6

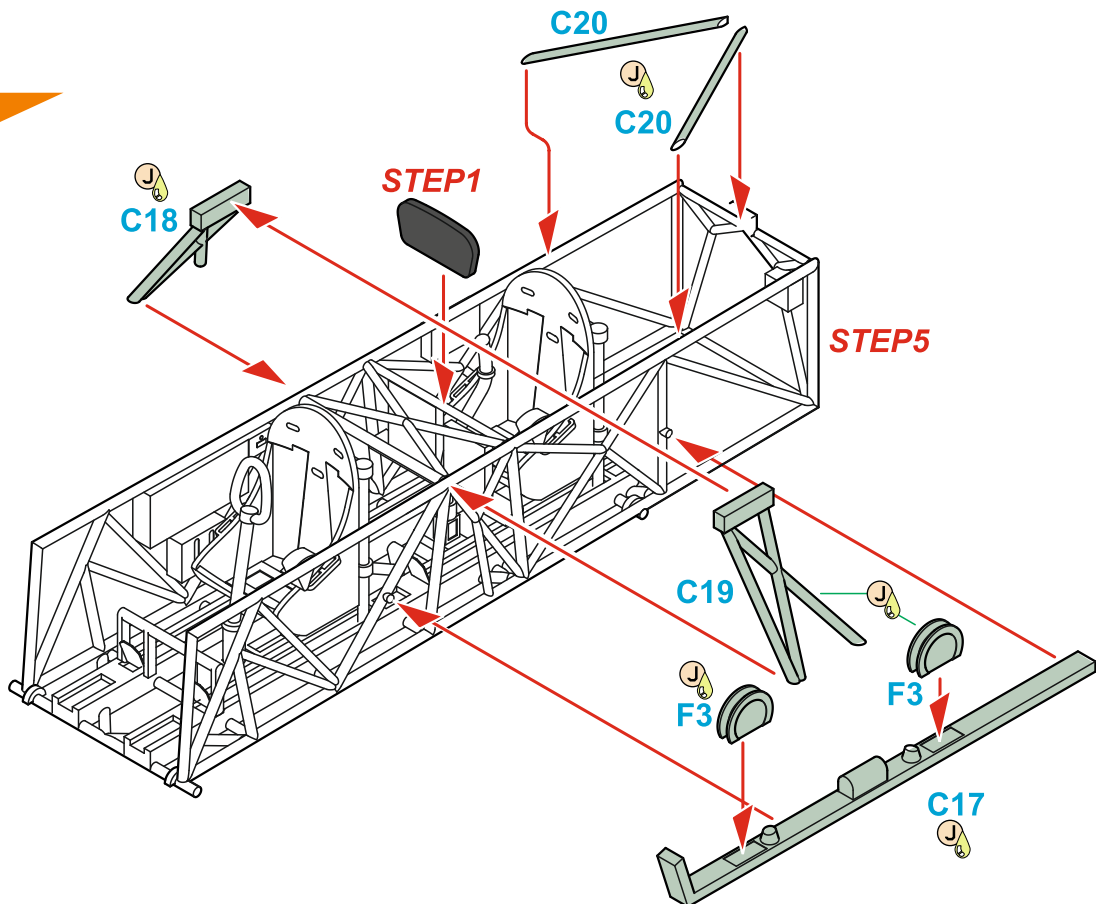

4

7

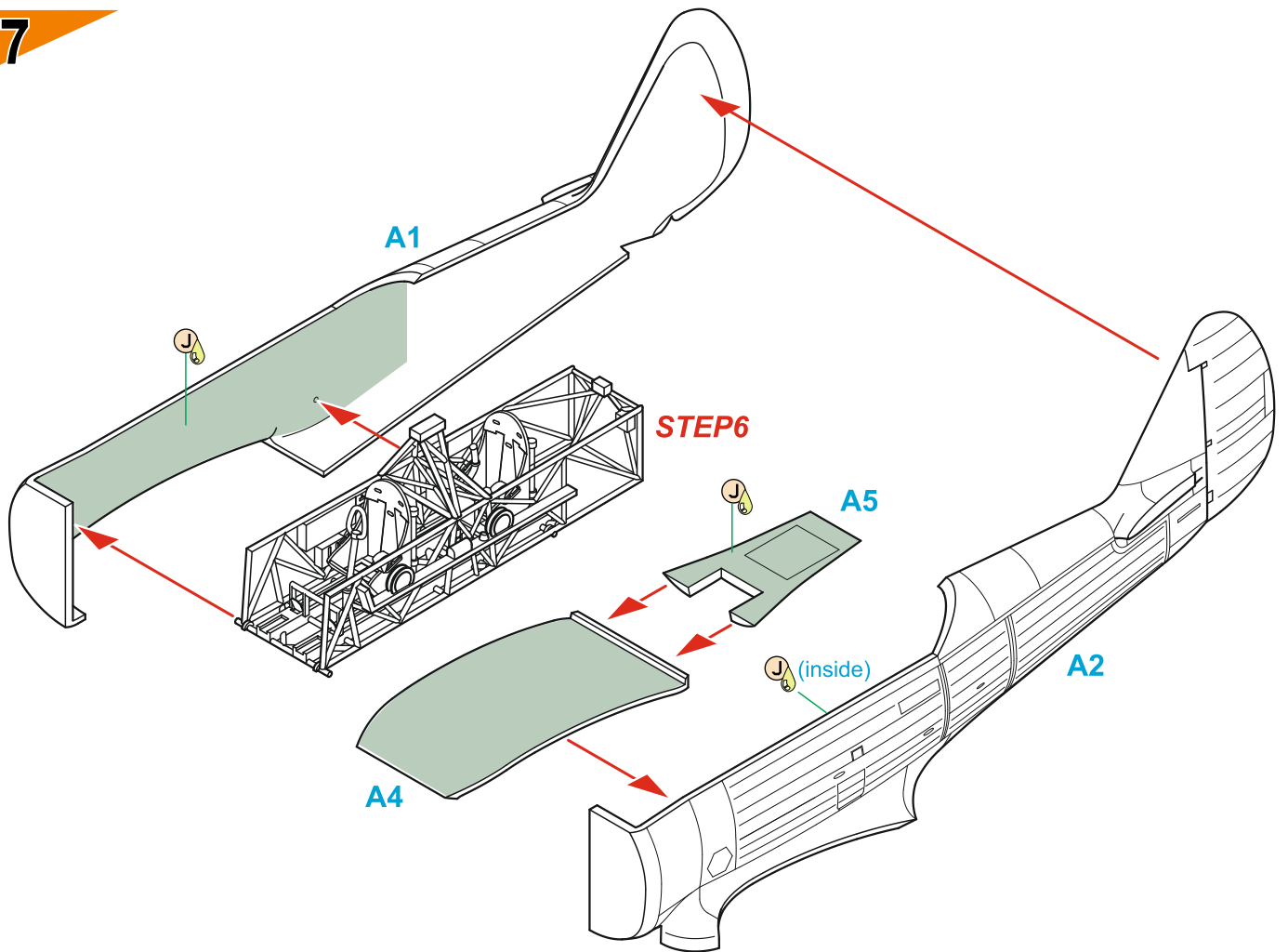

8

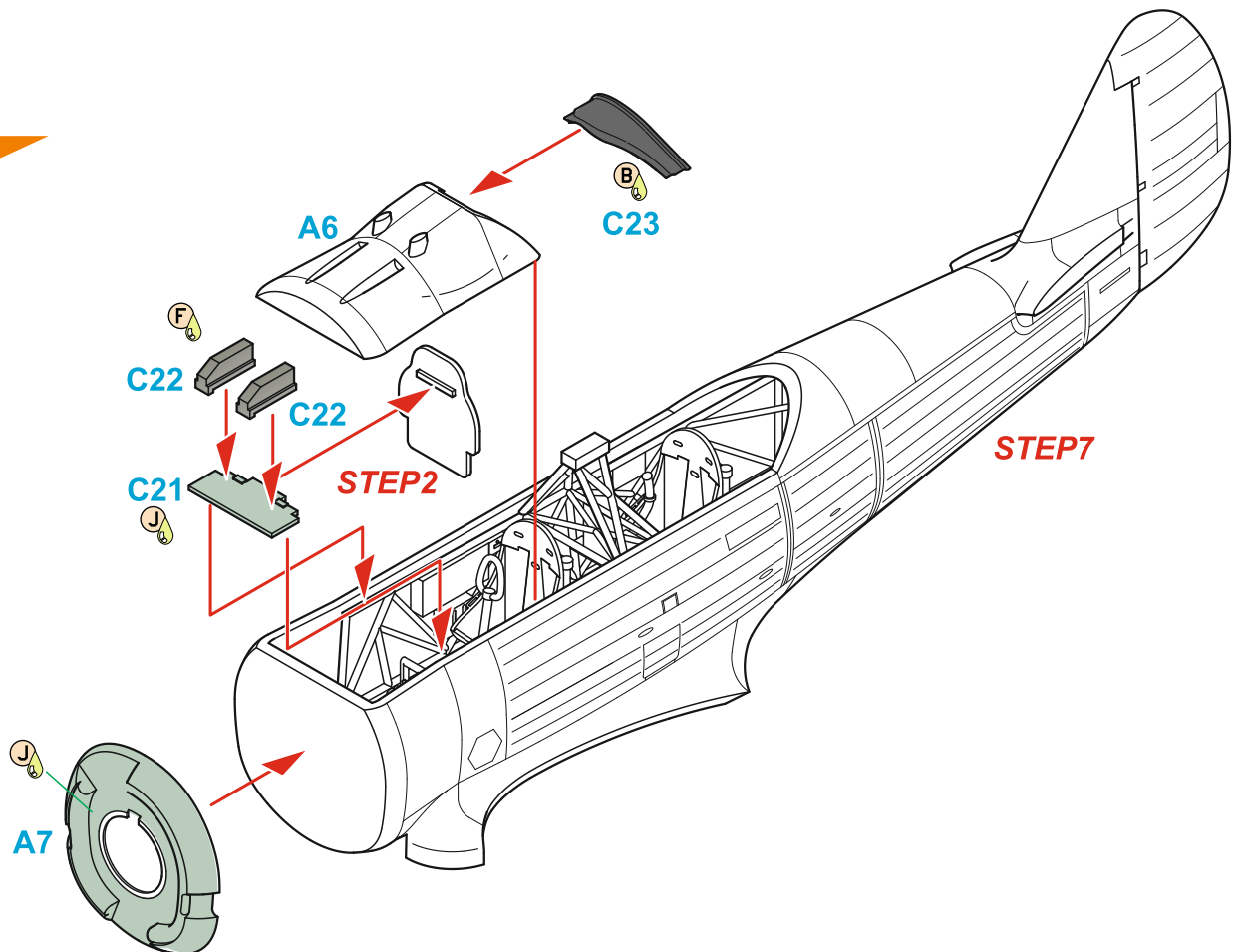

5

9

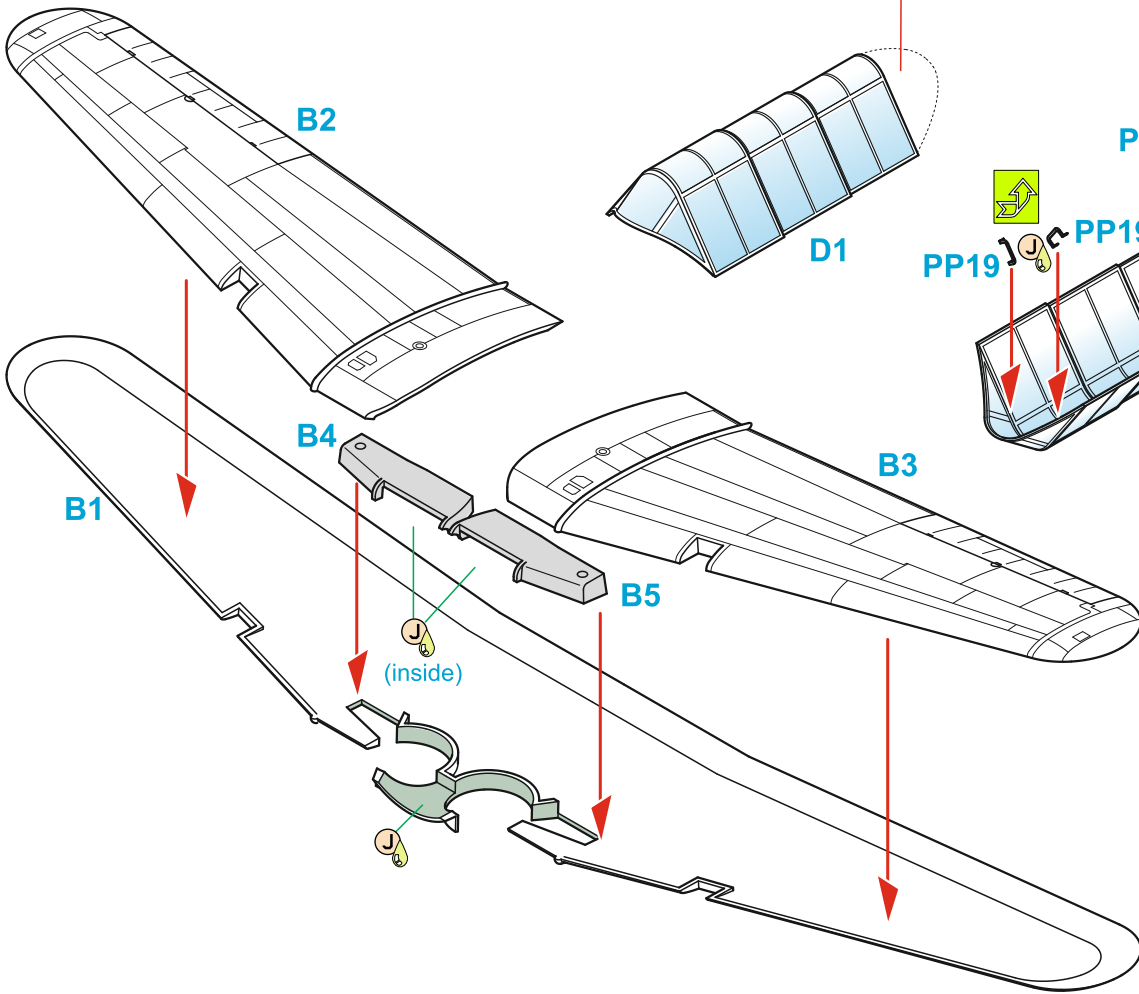

10

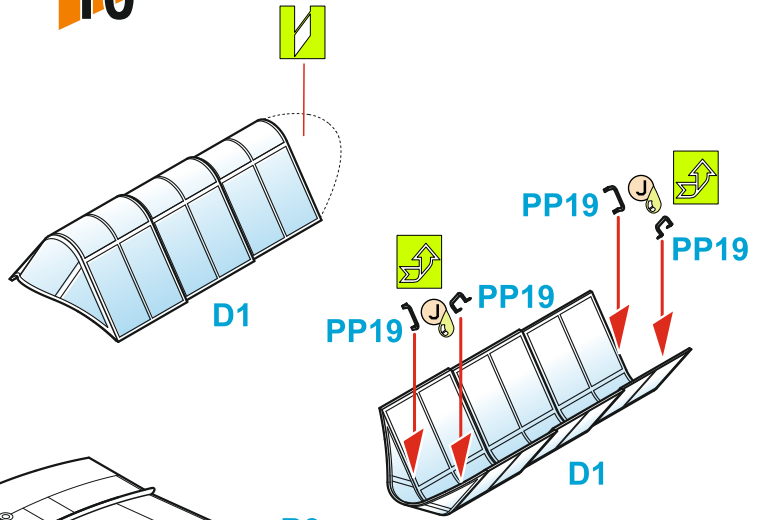

11

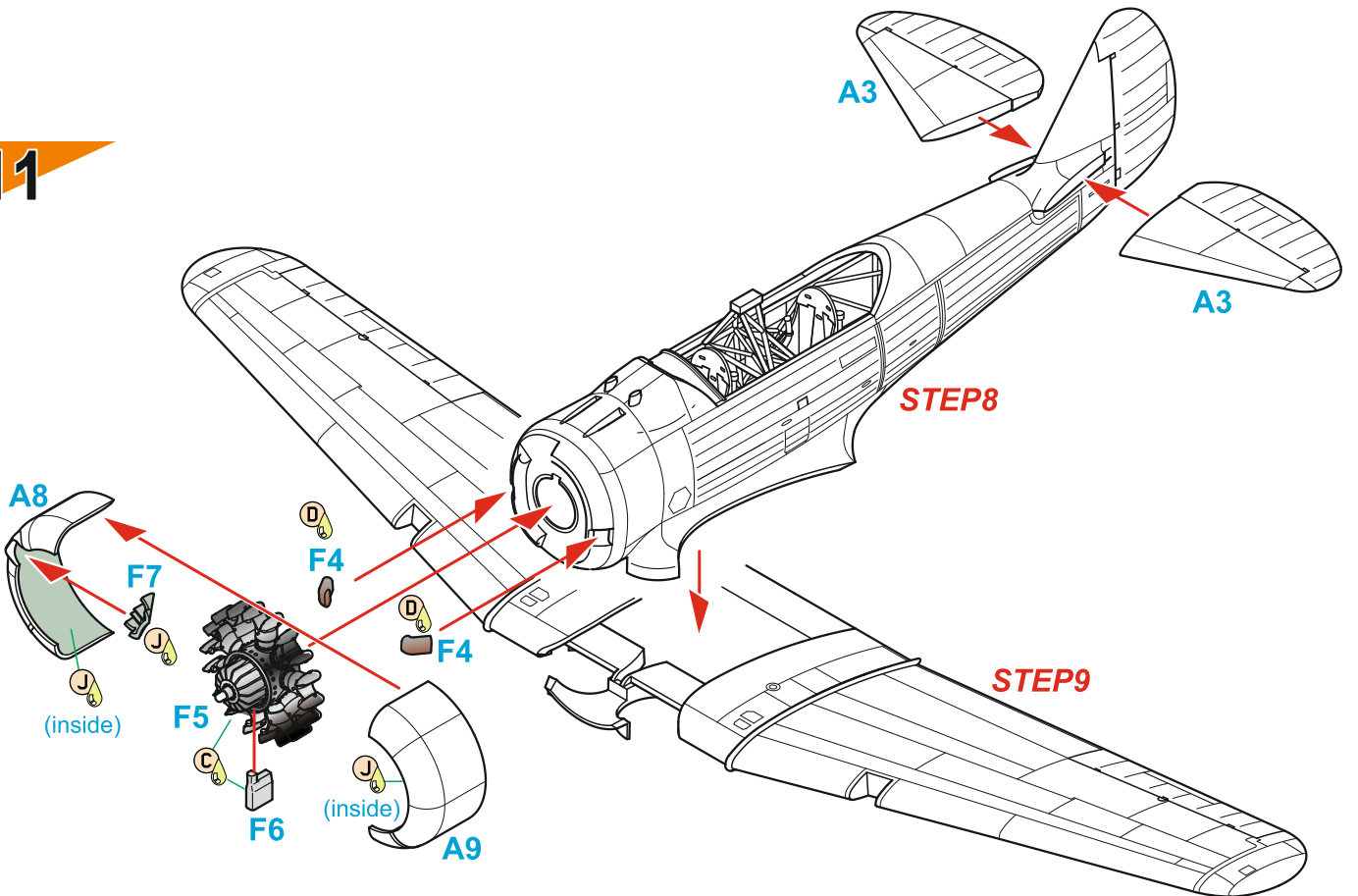

Pro vylepšení svého modelu můžete použít sadu odlévaných kol kat. číslo Q48 272 Boomerang/Wirraway wheels.

Více informací na www.specialhobby.eu nebo www.cmkkits.com.

To improve your model, use CMK resin wheel set cat. no. Q48272 Boomerang/Wirraway wheels.

More information at www.specialhobby.eu or www.cmkkits.com.

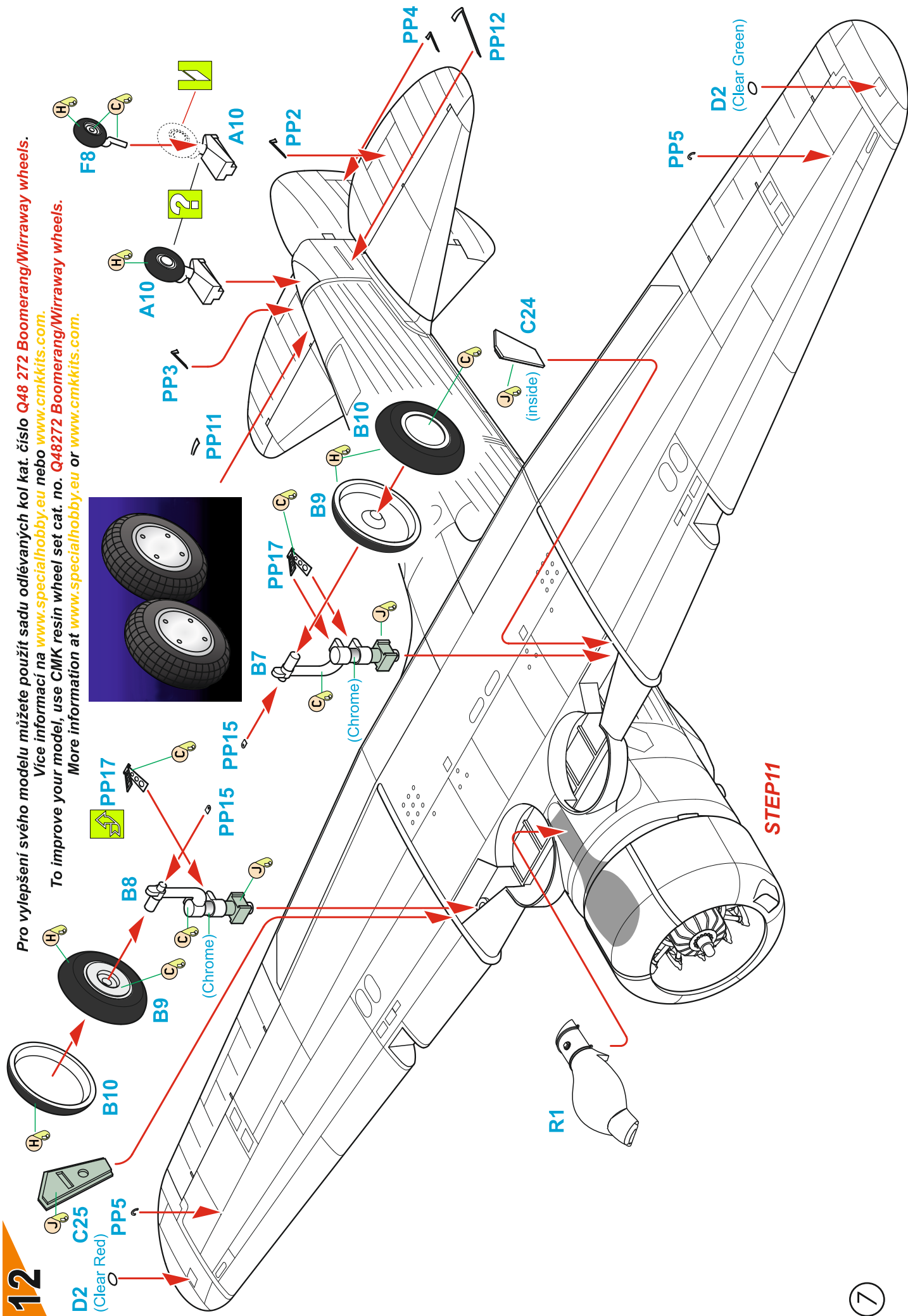

STEP 11

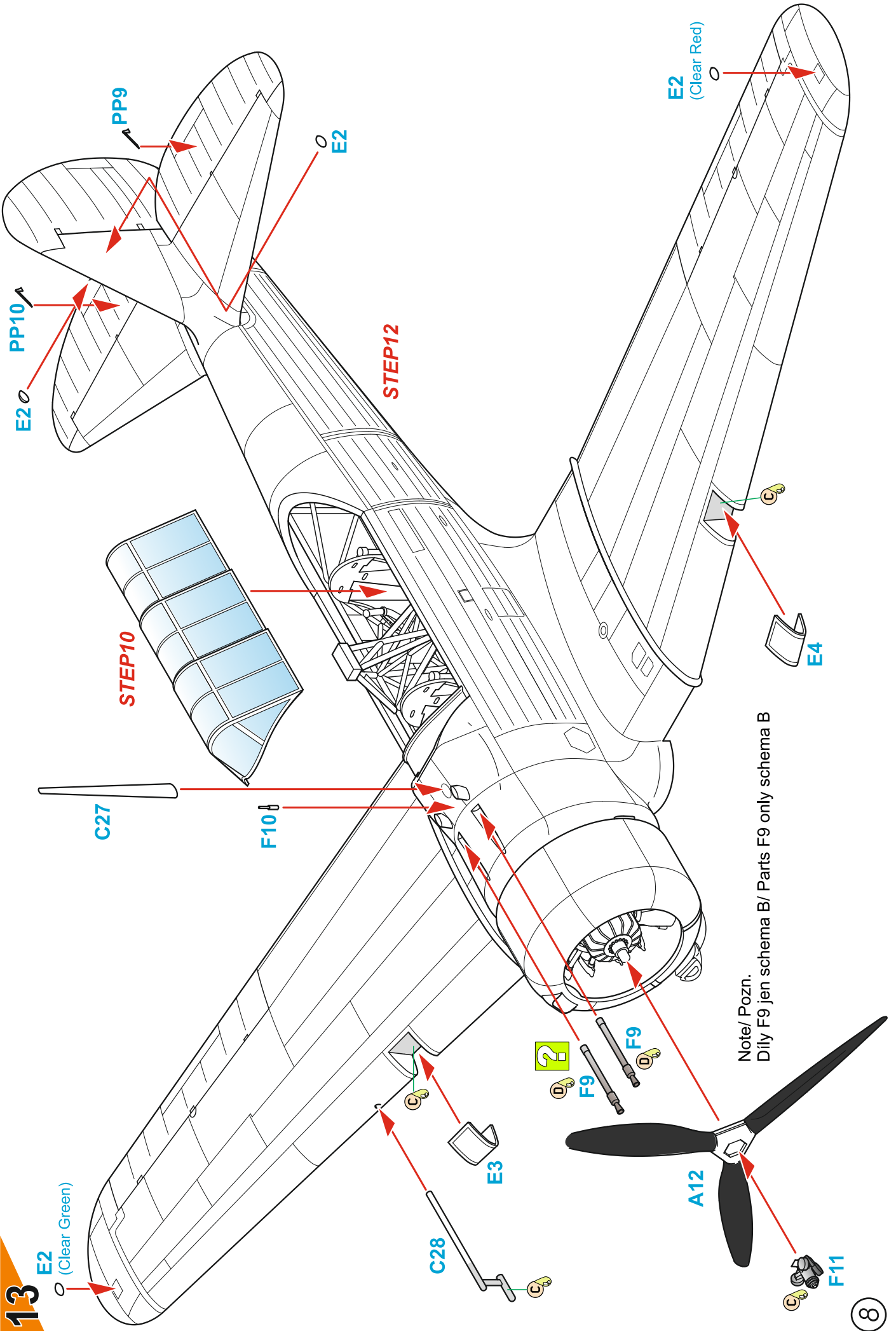

CAC CA-9 Wirraway, A20-617 (C/N 818), No.86 Sqn. RAAF, severní Austrálie, jaro/léto 1945. Letoun zůstal ve stejném zbarvení, v jakém létal u předchozího uživatele, No. 5 STFS, RAAF Station Uranquinty. Zadní část překrytu byla pravděpodobně použita z jiného, kamuflovaného Wirrawaye

CAC CA-9 Wirraway, A20-617 (C/N 818), No.86 Sqn. RAAF, Northern Australia, Spring/Summer 1945. The aircraft retained its original colours as flown by its previous operator the No.5 STFS at the RAAF Station Uranquinty. The camouflaged rear section of the canopy was most likely taken from another all-green Wirraway.

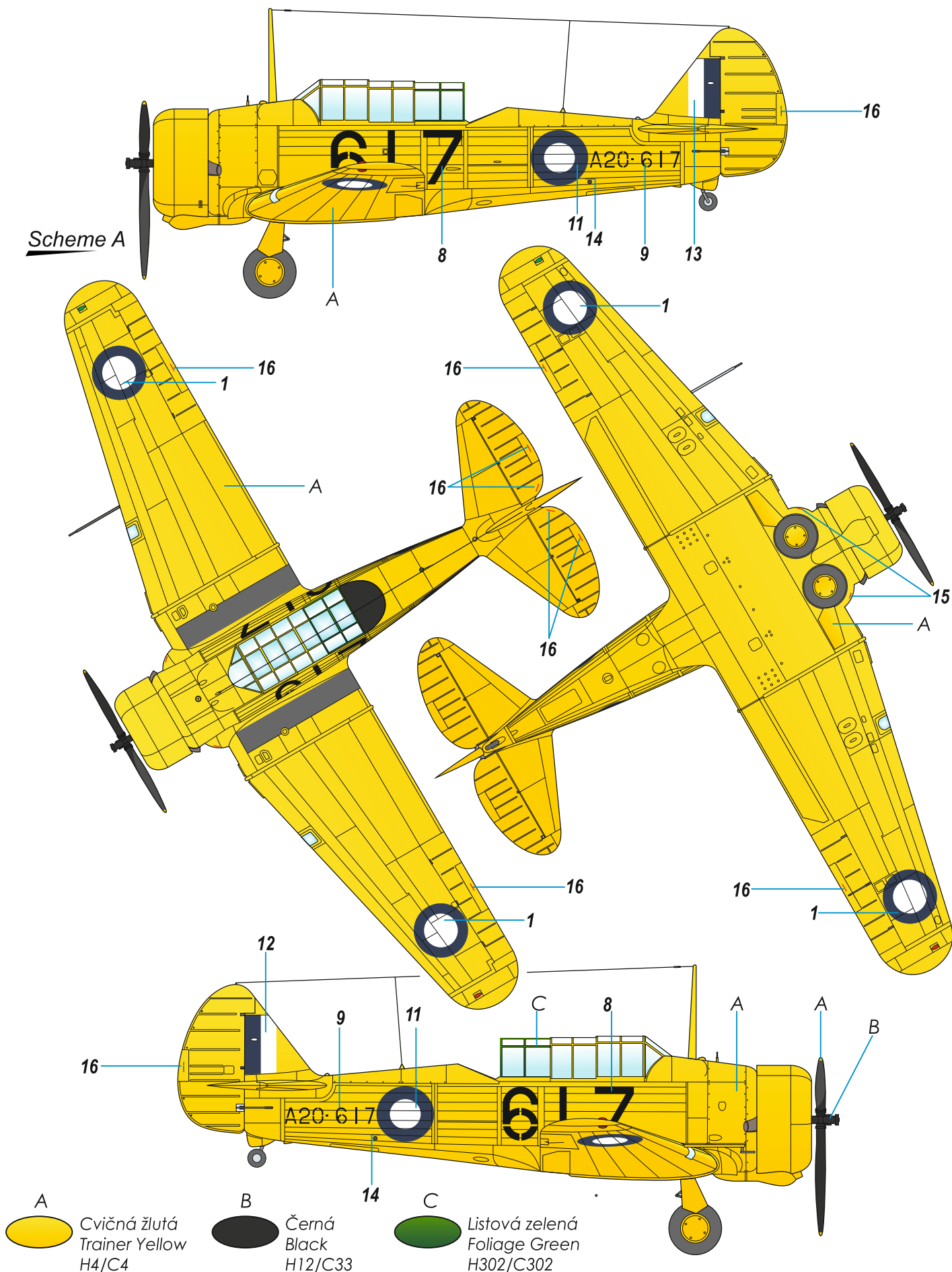

CAC CA-9 Wirraway, A20-637 (C/N 1089), No.4 Sqn. RAAF, New Guinea, 1944. Při letu ze základny Nadzab do Madangu se u Alexishafenu prudce zhoršilo počasí. Letoun nemohl pokračovat v letu pro nízké mraky, které skryly hory na pobřeží. Po vyčerpání paliva se pilotovi P/O P.H Sandersovi podařilo přistát bez podvozku na místní cestě. On i jeho pozorovatel LAC N.D Mead zůstali nezraněni, ale letoun byl odepsán. Starší publikace Wirraway A20-637 prezentovaly v třibarevné kamufláži. Ve skutečnosti byl ale dodán v barvě Foliage Green. U squadrony byly doplněny rozpoznávací prvky spojeneckých letadel, bílá zbarvení náběžné hrany křídla a ocasních ploch.

CAC CA-9 Wirraway, A20-637 (C/N 1089), No.4 Sqn. RAAF, New Guinea, 1944. During the flight from the Nadzab base to Madagan the weather in the Alexishafen area turned bad quickly and the pilot could not fly further because of low clouds covering the coastal mountains. After running out of fuel, P/O P.H Sanders had to made a forced landing on a local road with the undercarriage up. Both the pilot and his observer LAC N.D Mead escaped unhurt but their plane was a write-off. Some earlier publications show Wirraway A20-637 wearing a three-tone scheme although the airframe was in fact delivered in Foliage Green overall. At the unit level the Allied ID markings were painted, white wing leading edges and white empennage.

Scheme B

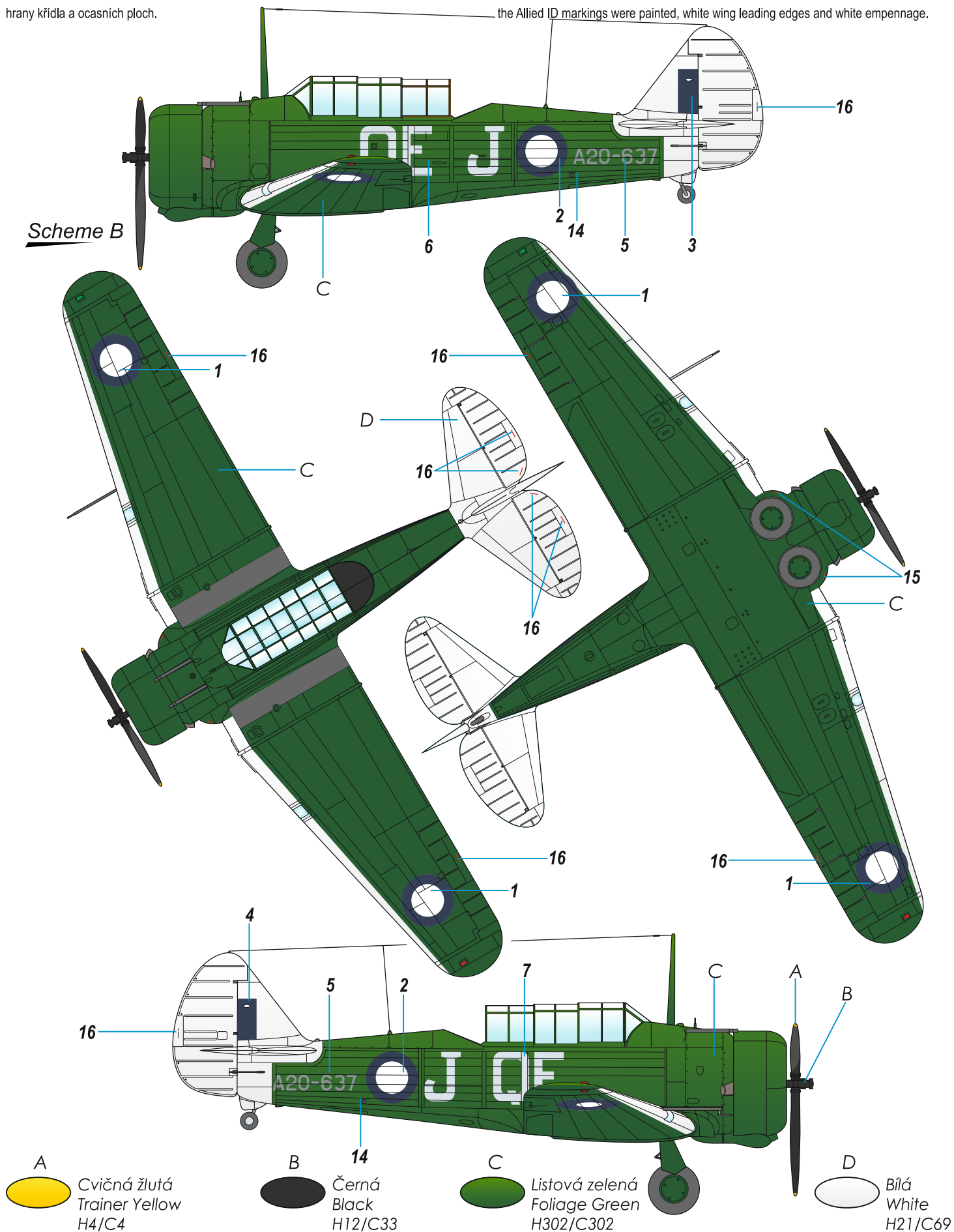

A Cvičná žlutá
Trainer Yellow
H4/C4

B Černá
Black
H12/C33

C Listová zelená
Foliage Green
H302/C302

D Bílá
White
H21/C69

ATTRACTIVE 1/48 SCALE MODELS



SH48195



'Overseas Jockeys'
Supermarine Spitfire Mk.VC



SH48241

'Jungle Scouts'
CAC CA-19 Boomerang



SH48239



'Pacific Warriors'
L-4/NE-1 Grasshopper

Special HOBBY

 facebook.com/specialhobby

WWW.SPECIALHOBBY.EU

1/48 resin kits and resin and 3D printed sets and figures for RAAF lovers produced by Special Hobby

Decal Options

RAAF USAAF

Cockpit Parts

4398
F-4A-1 Recon Lightning
Conversion Set
1/48
Contains detail resin parts, clear resin parts and two decal options. For Tamiya kit No 61120

Decal Options

A8-II6 RAAF (2x)

4406
Beaufighter Mk.21
Conversion Set
1/48
Contains detail resin parts, clear vacuformed parts and two decal options. For Revell kit.

4458
1/48
2000 Lb Bomb AN-M66A2
equipped with Fin
Assembly M116A1 (2 pcs.)

© Special Hobby 2022

4461
1/48
B-25 Mitchell Wheels
Circumferential Tread Pattern
for Accurate Miniatures,
Academy, Italeri and Revell kits

PUR - Polyurethane parts

© Special Hobby

4467
1/48
PV-1 Ventura
Pilot Cockpit
set for Revell and Academy kits

Polyurethane parts - PUR Photo-etched parts - PE

3D Printed parts - PP
2x

Film - F
Decal - D

© Special Hobby 2023

4469
1/48
PV-1 Ventura Nose
and Turret Armament
for Revell and Academy kits

© Special Hobby 2023

P48007
1/48
B-25D Late/G/H/J Mitchell
Pilot Seats
for HK, Acc. Miniatures, Academy
and Revell kits

PE - Photo-etched parts
CMK 4466 B-25 Pilot Seats

3D-Printed Parts

© Special Hobby 2023

P48009
1/48
B-25B/C/D/G Mitchell
Wings Air Intakes
Correction Set
for Acc. Miniatures, Italeri, Revell and Academy kits

3D Printed Parts

© CMK 2015

F48 278
1/48
RAAF WW II Pilot
(Pacific 1944/45)

PUR - Polyurethane parts

Need variations!
Flying Helmet / RAAF Hat

© CMK 2015

CAC CA-6 Wackett
'RAAF Basic Trainer'

Resinový model
Resin kit

No. 148
1:48

Made in Czech Republic

Commonwealth Ca-15
'Kangaroo'

Model obsahuje podvozkové nohy odlité z bílého kovu
Kit contains white metall undercarriage legs

No. 232
1:48

Made in Czech Republic