



Defiant Mk.II 'Radar Fighter'

INSTRUCTIONS

GB In response to a British Air Ministry requirement, the company Boulton & Paul produced their P.82 design in 1935. The aircraft was to replace the turret version of the Hawker Demon which was then in service with the RAF. By the time the prototype aircraft was completed, the company aircraft division had moved from Norwich to Wolverhampton and been renamed Boulton Paul Aircraft Ltd. The prototype first took to the air on 11th August 1935, later being named Defiant. The Defiant Mk.I entered service with 264 Squadron of the RAF in late 1939 and saw action over the Hague and Dunkirk in May 1940. Once the Battle of Britain had begun, 141 Squadron joined 264 to become the second daytime fighter unit to be equipped with the Defiant. Transferring to the night-fighter role, the Defiant went on to equip a number of squadrons. By the autumn of 1941, the aircraft were being supplied with the A.I Mk.IV radar and were designated Defiant Mk.IA. At the end of the year the Defiant squadrons achieved the highest number of kills per interception of any of the night-fighting units. Over 700 Defiant Mk.I airframes were built with 150 of them being converted to TT.III configuration for use by many army and navy units for gunnery training.

Technical Specification: Span 39ft 4in (11.99m). Length 35ft 4in (10.77m). Rolls Royce Merlin III 1,030hp (767.6 kW). Top Speed 250mph at sea level (402km/h), 304mph at 17,000ft (489km/h at 5,182m). Service ceiling was 30,350ft (9,251m). Range was 465 miles at 259mph (748 Km). Armament Boulton Paul A Mk.IID Turret with 4 x .303in Browning with 600 rounds per gun.

CZ Jako odpověď na požadavek Britského Ministerstva pro letectví navrhla v roce 1935 firma Boulton & Paul prototyp označený jako P.82. Tento letoun měl nahradit letoun Hawker Demon se střeleckou věží, který byl v té době ve službě u jednotek RAF. V době, kdy byl prototyp letounu dokončován, letecká divize firmy Boulton & Paul se přestěhovala z Norwiche do Wolverhamptonu a byla přejmenována na Boulton Paul Aircraft Ltd. Prototyp poprvé vzlétl 11. srpna 1935 a byl později pojmenován Defiant. Letouny Defiant Mk.I byly operačně nasazeny u 264. peruti RAF koncem roku 1939 a zúčastnily se bojových operací nad Haagem a Dunkirkem v květnu 1940. Poté co začala Bitva o Británii, byla letouny Defiant vyzbrojena také 141. perutí RAF a připojila se k 264. peruti jako druhá denní stíhací jednotka, která byla vyzbrojena letouny Defiant. Letouny Defiant Mk.I byly pak převedeny do role nočních stíhacích letounů a byly jimi vyzbrojeny další peruti. Na podzim 1941 byly letouny vyzbrojeny radarem A.I.Mk.IV a byly označeny jako Defiant IA. Do konce roku 1941 pak docílily nejvyšší počet sestřelů ze všech nočních bojových jednotek při přepočtu na počet kontaktů s nepřátelskými letouny. Celkem bylo postaveno 700 kusů letounů Defiant Mk.I, 150 z nich bylo později přestavěno na model TT.III.

Technické údaje: rozpětí 11,99 m, délka 10,77 m. Motor Rolls Royce Merlin III o výkonu 1030 hp, nejvyšší rychlost 402 km/hod u hladiny moře, 489 km/hod ve výšce 5182 m, operační dostup 9251 metrů, dolet 748 km. Výzbroj- střelecká věž Boulton Paul A Mk.IID se čtyřmi kulomety Browning ráže 0.303 palce.

1

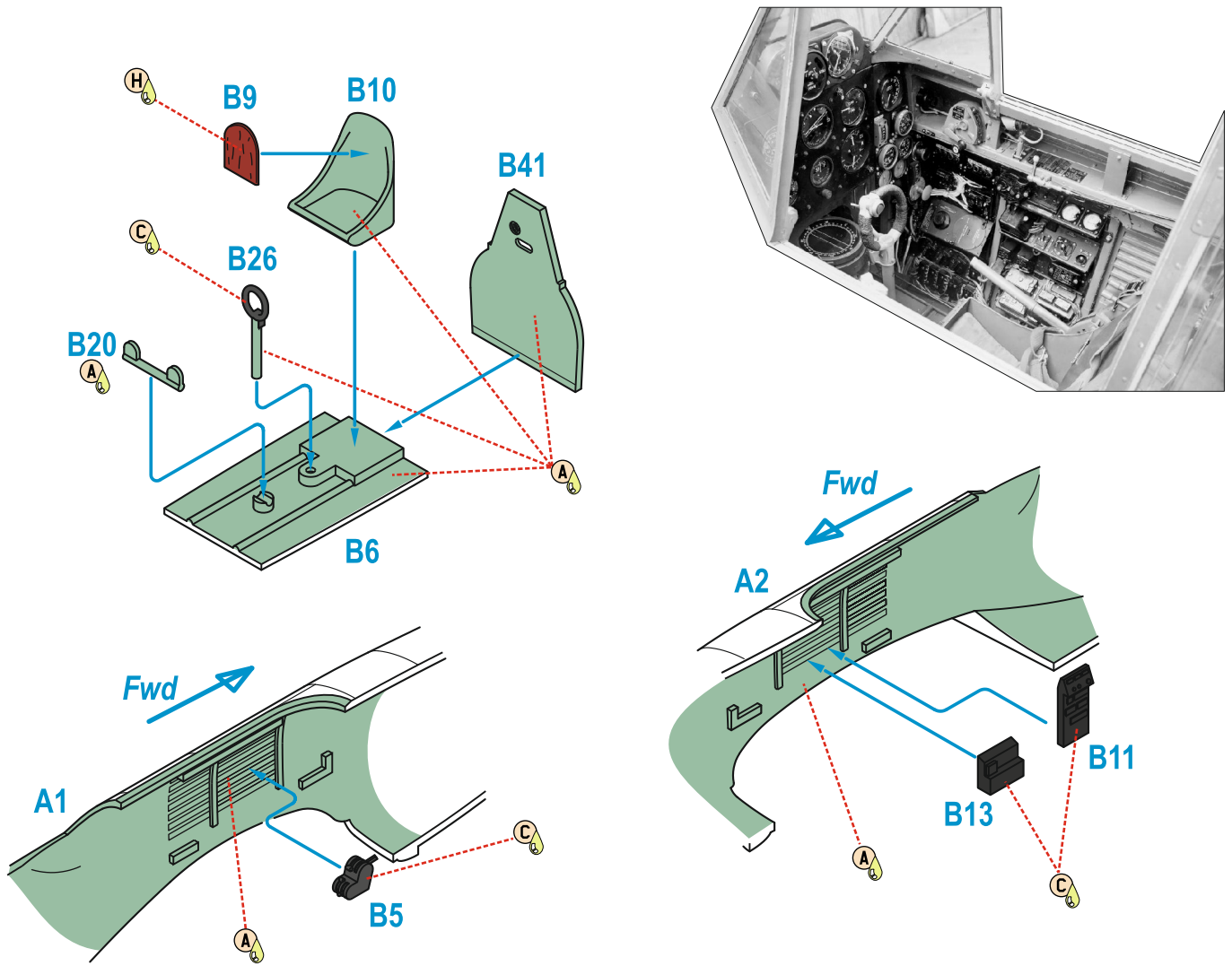

2

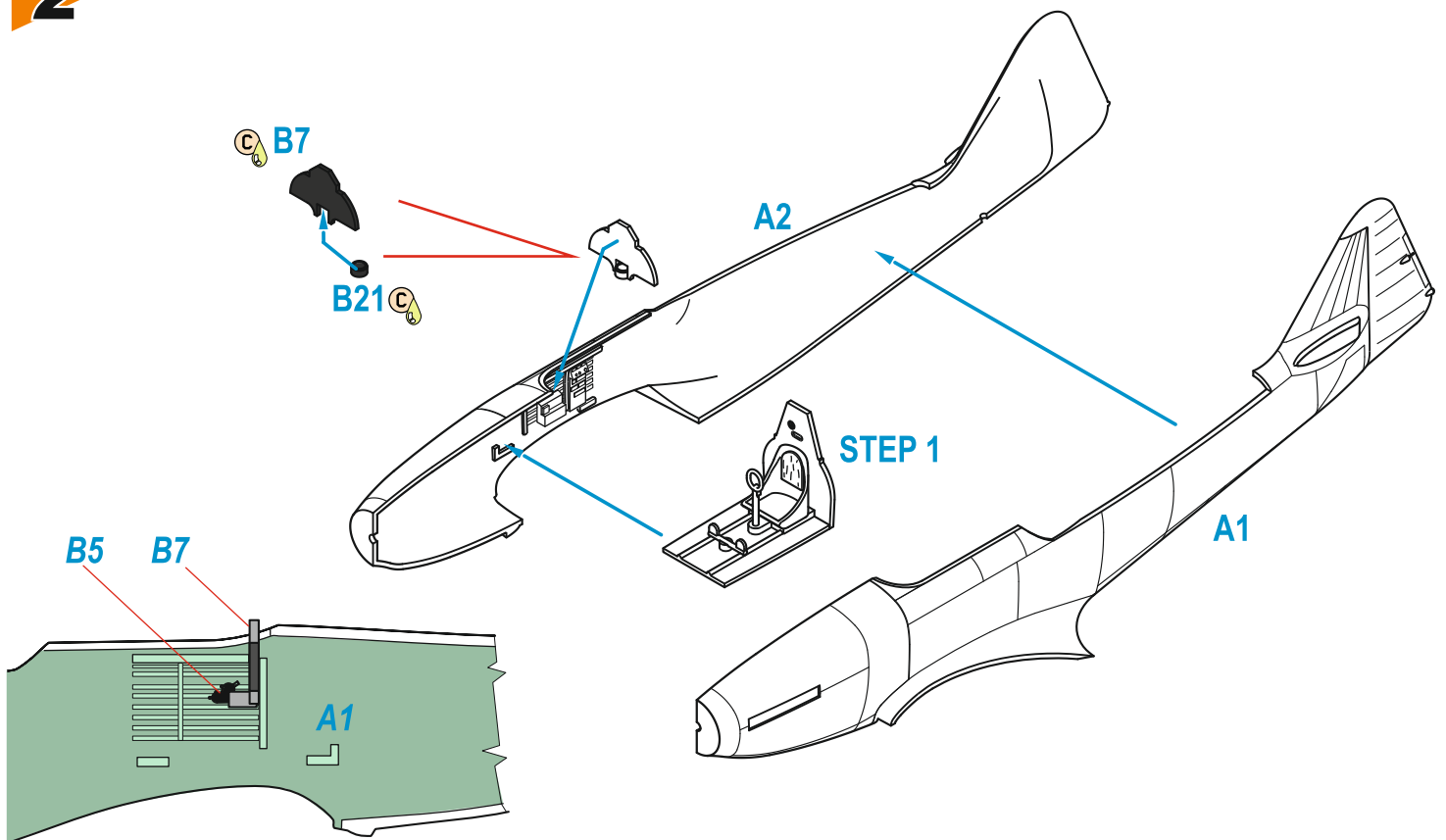

3

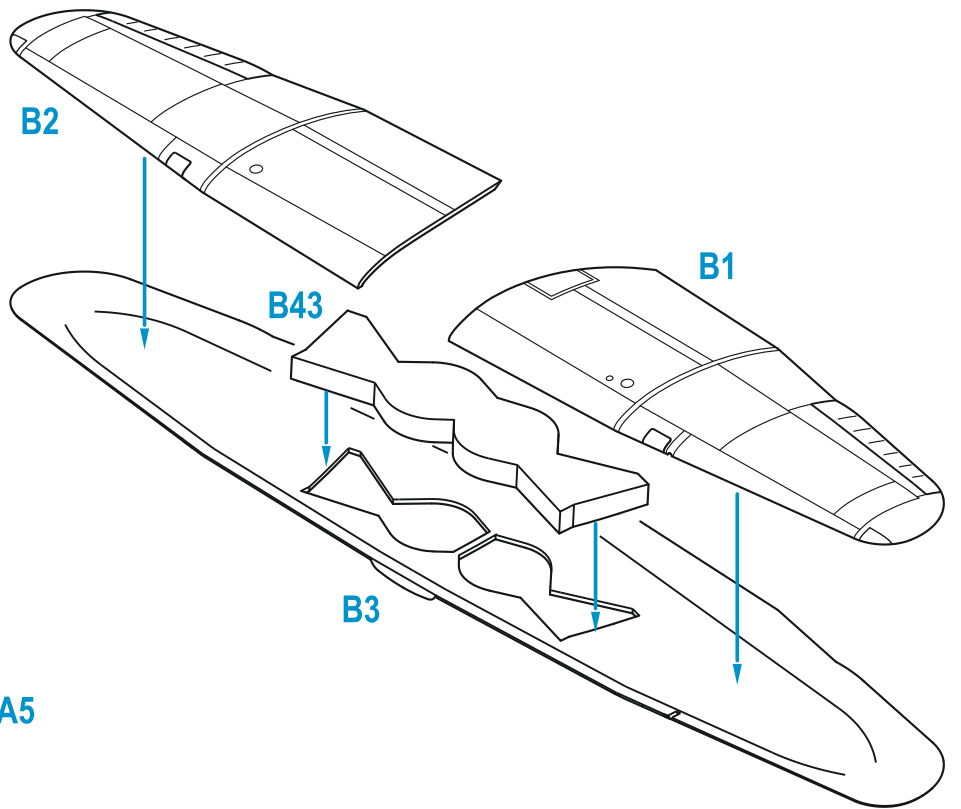

4

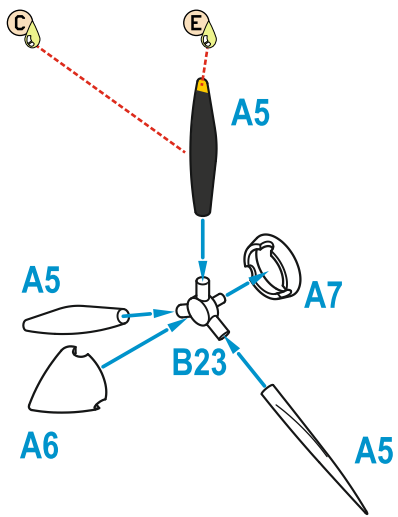

5

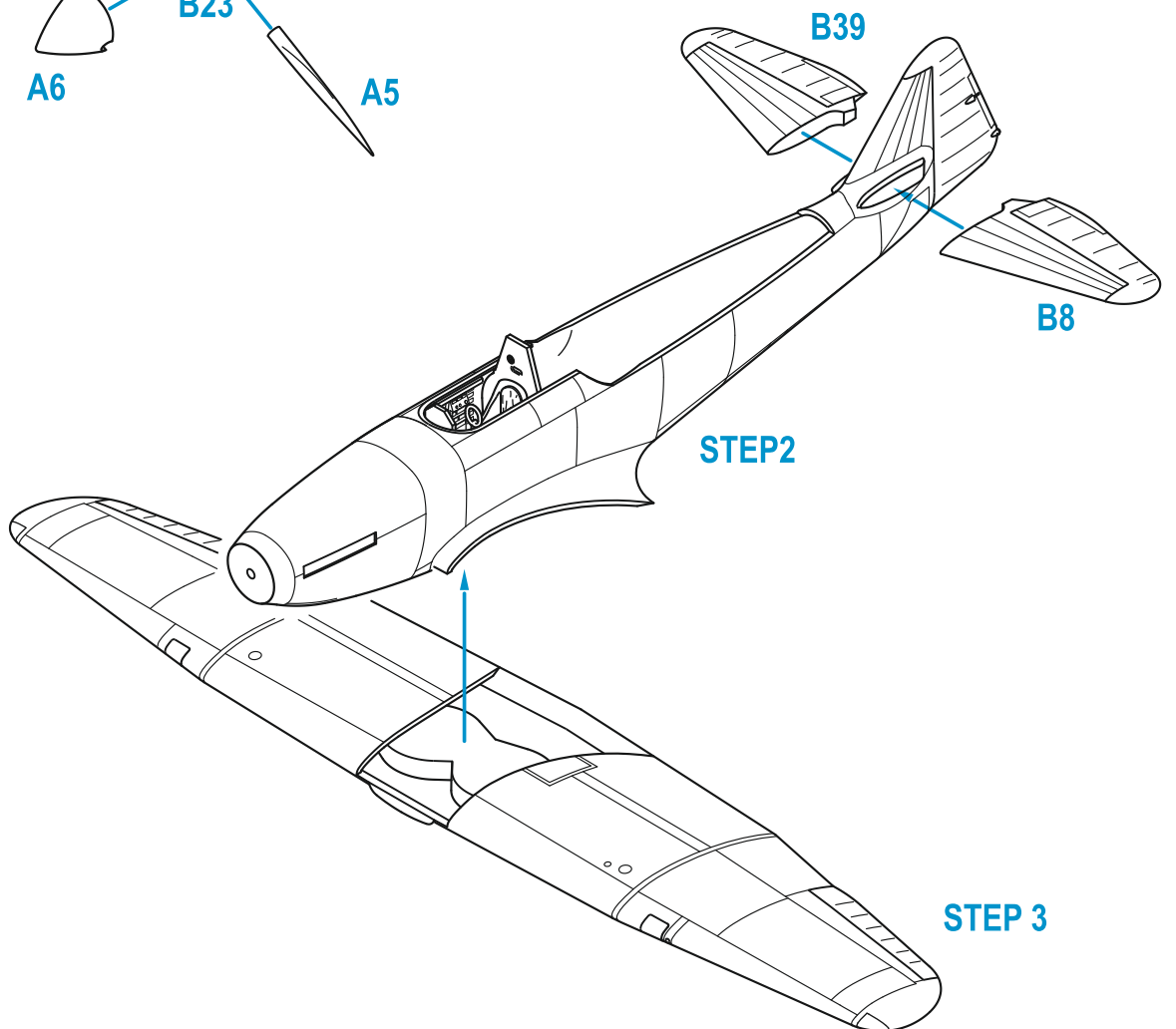

6

POZN:

letová pozice -
vysunutý zadní
stožár antény (B28)

NOTE:

Flight position -
shifted out
rear antenna mast.

Stejné
číslo?

7

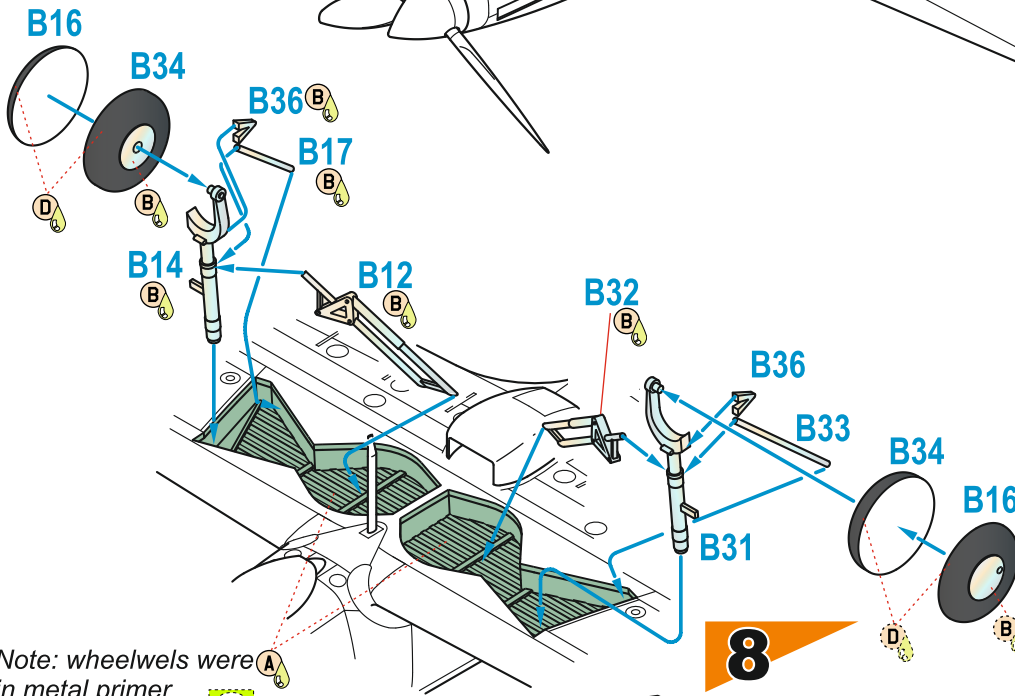

Note: wheelwells were
in metal primer
grey green colour
(FS 34226)
or repainted in black colour

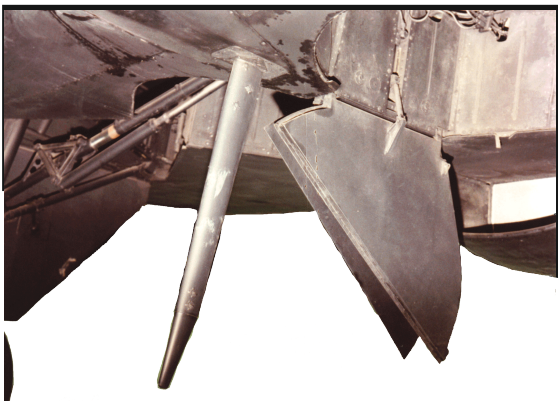

U/C LEG - PORT/ levá podv. noha

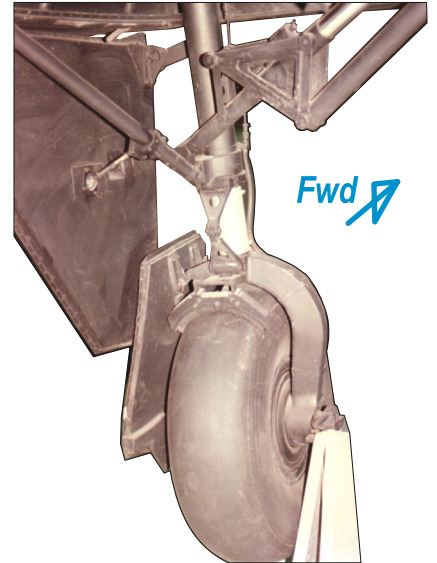

8

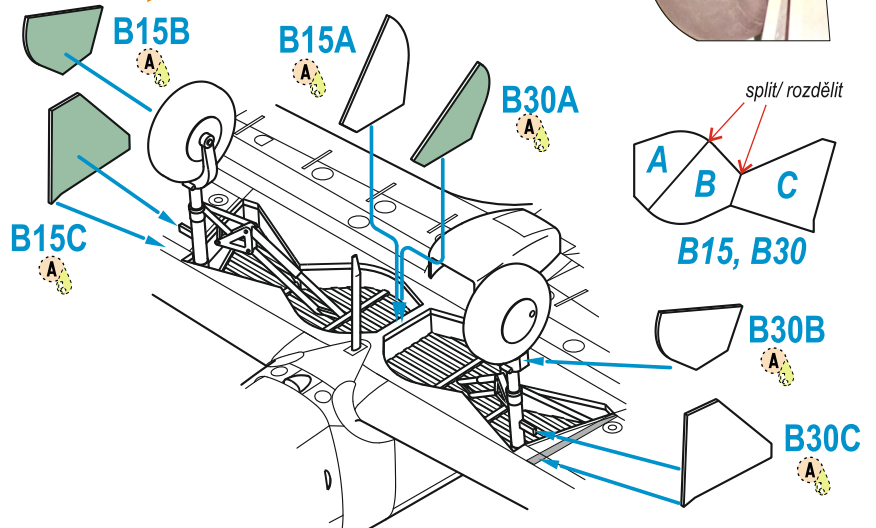

split/ rozdělít

B15, B30

B30B

B30C

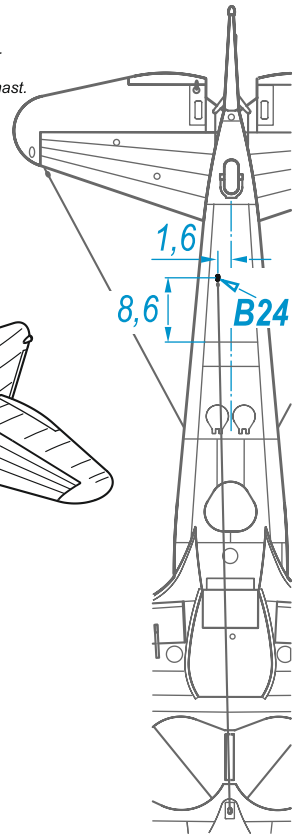

1,6
8,6
B24

9

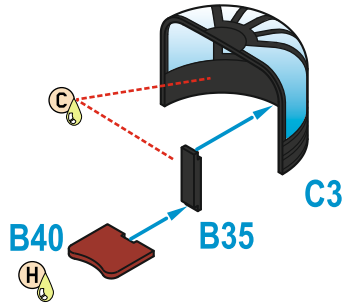

10

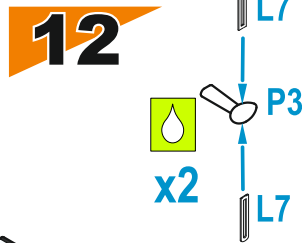
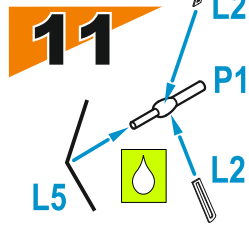
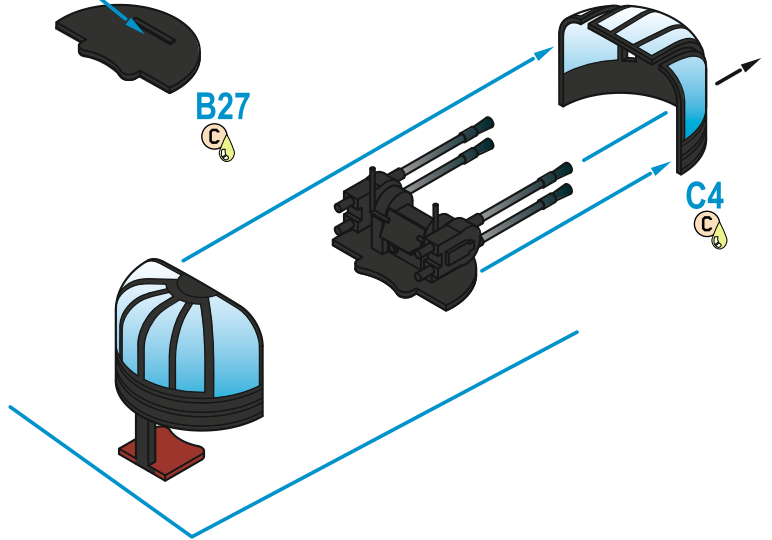
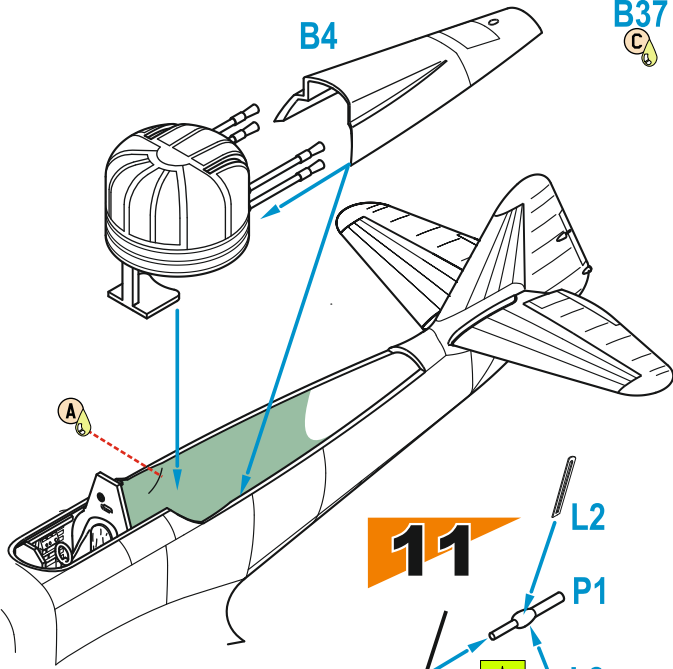
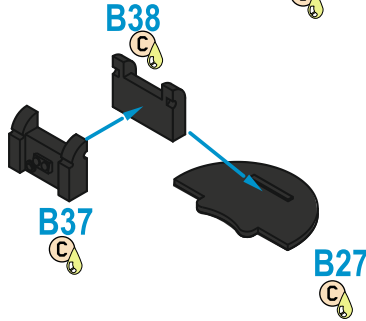
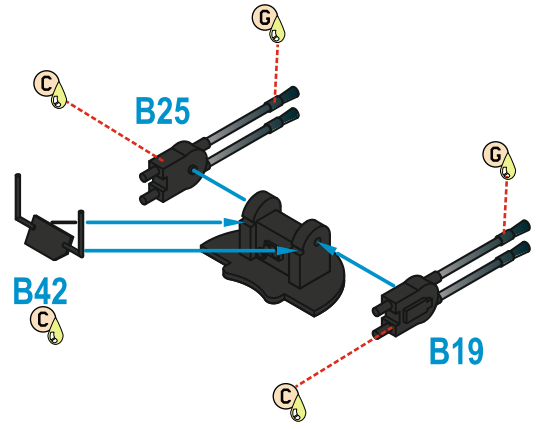

14

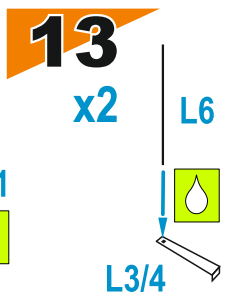
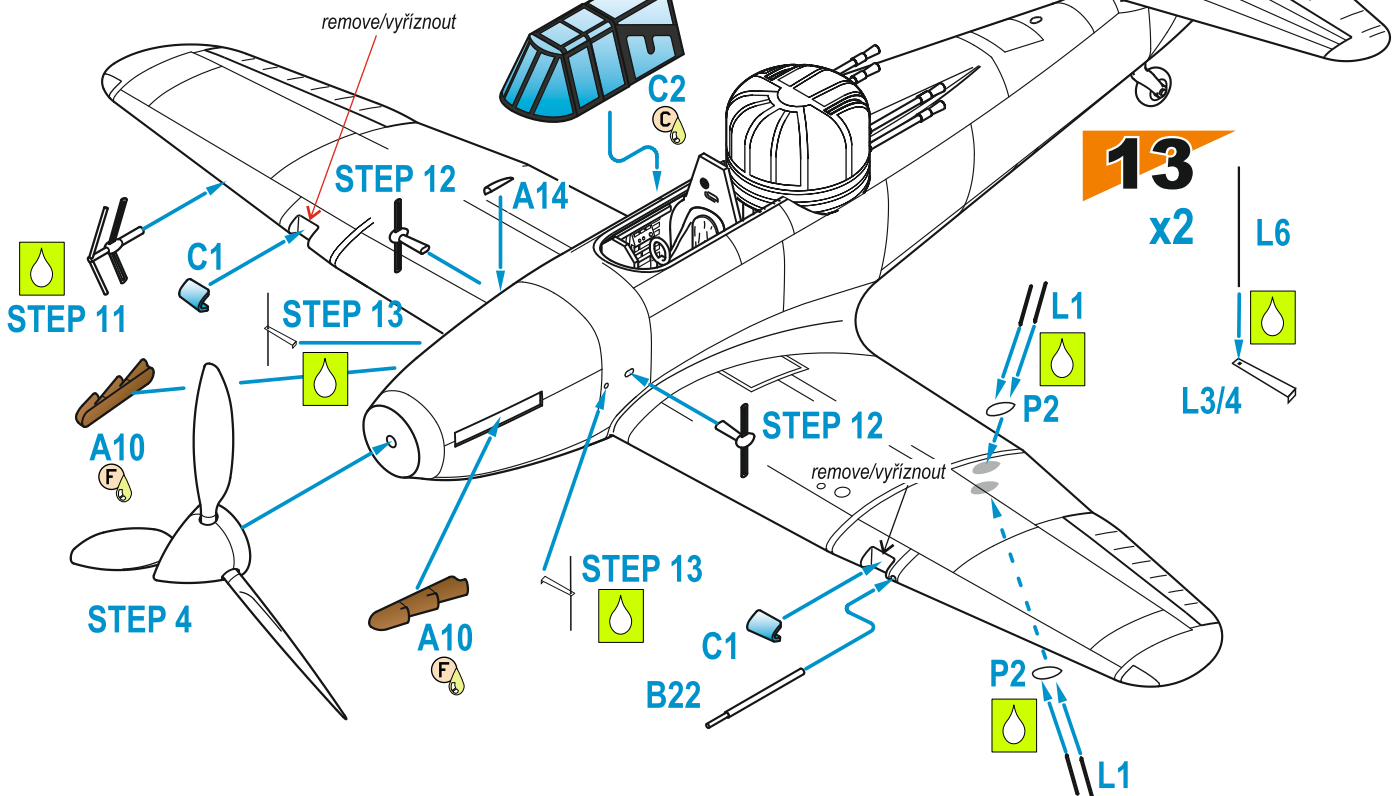

Defiant NF Mk.II, AA583 / ZJ-M, NO.96 Sqn. RAF, Sqn. Ldr. R.C. Haine, RAF Wrexham, Spring 1942. S/L Richard Cummings Haine, later to become G/C, OBE, DFC, achieved a total of five aerial kills in the war, majority of which at night, one of the kills while flying a Defiant. On 28 November 1939 during the attack on German-seized Waalhaven airfield in the NEtherlands, Haine flying a Blenheim was shot down but avoided capture. During the invasion, he was the CO of No 488 Sqn RNZAF, flying Mosquitoes. Went on to serve with the RAF until 1970, among other tasks Haine took part in flight testing the Phantom II for the RAF, which he described in his autobiography named *From Fury to Phantom: An RAF Pilot's Story 1936-1970*. Died on 30 September 2008, just two days before his 92nd birthday.

Defiant NF Mk.II, AA583 / ZJ-M, NO.96 Sqn. RAF, Sqn. Ldr. R.C. Haine, základna RAF, Wrexham, jaro 1942. Pozdější G/C Richard Cummings Haine OBE, DFC, dosáhl během války 5 sestřelů, část z nich byla nočních, z toho jeden na Defiantu. 28.11.1939 byl sestřelen na Blenheimu při útoku na němci obsazené letiště ve Waalhavenu (Nizozemi), vyhnul se ale zajetí. Během invaze velel No. 488 Sqn. RNZAF a létal na Mosquitech. V řadách RAF sloužil až do roku 1970. Podílel se mimo jiné na testech Phantomu II pro RAF. Napsal autobiografii *From Fury to Phantom: An RAF Pilot's Story 1936-1970*. Zemřel 30. 9. 2008, den před svými 92. narozeninami.

Camo A

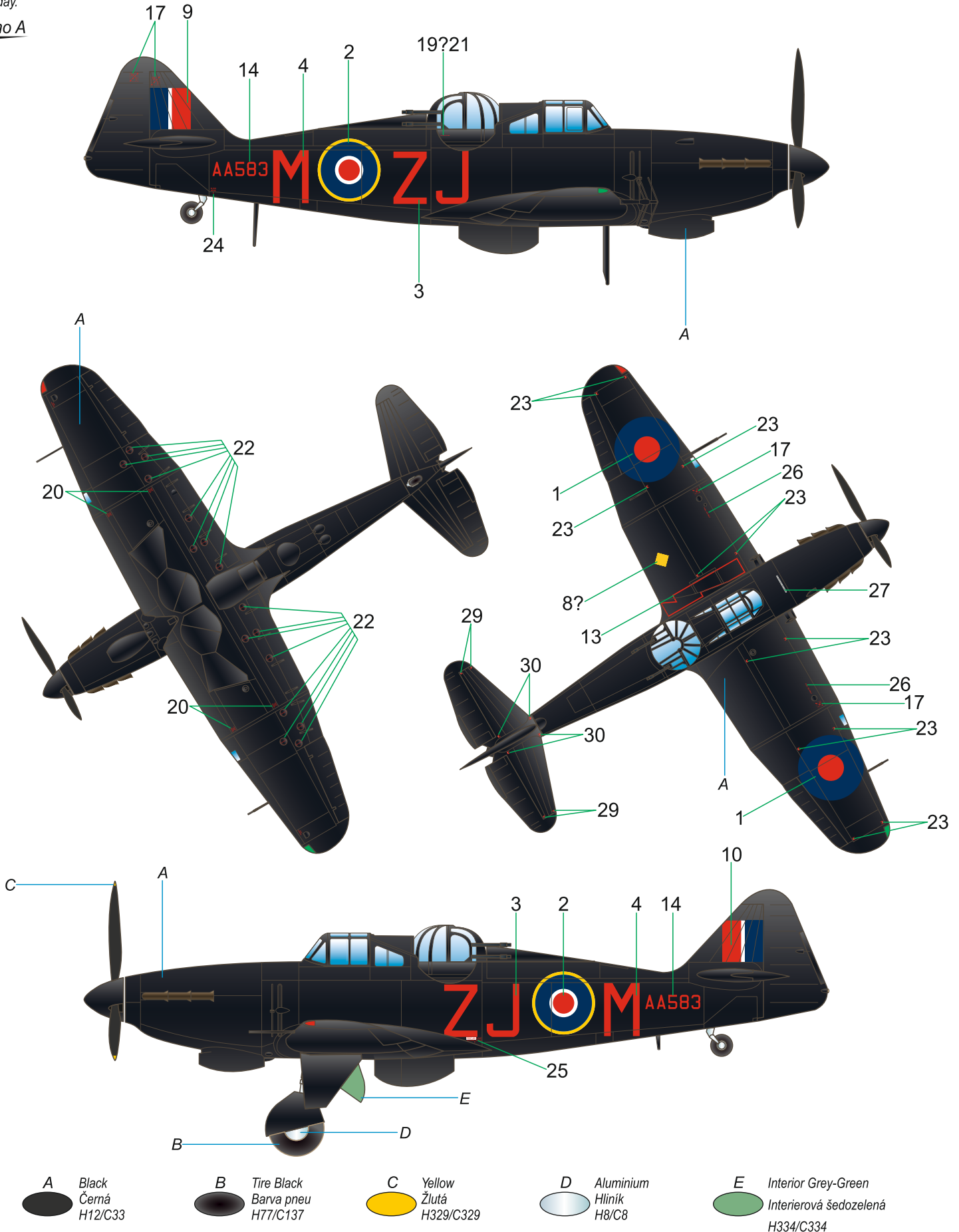

Defiant NF Mk.II, AA436 / DZ-V, No.151 Sqn, RAF Wittering, 1942. AA436 is usually depicted being fitted with radar antennae. The photos we have do not seem to show neither the radar nor the associated antennae. Therefore we have to leave it up to your decision to use this equipment or rather not.

Defiant NF Mk.II, AA436 / DZ-V, No.151 Sqn. RAF, základna RAF Wittering, 1942. Stroj AA436 je zobrazován s radarem. Nám dostupné fotografie montáž radaru a jeho antén neukazují. Je na vašem uvážení, zda při stavbě tohoto stroje antény použijete.

Camo C

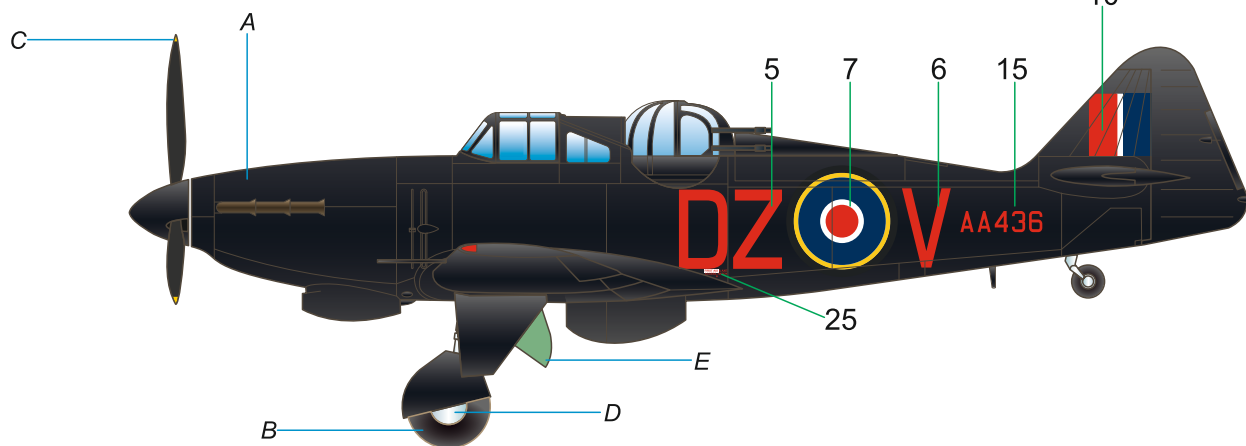
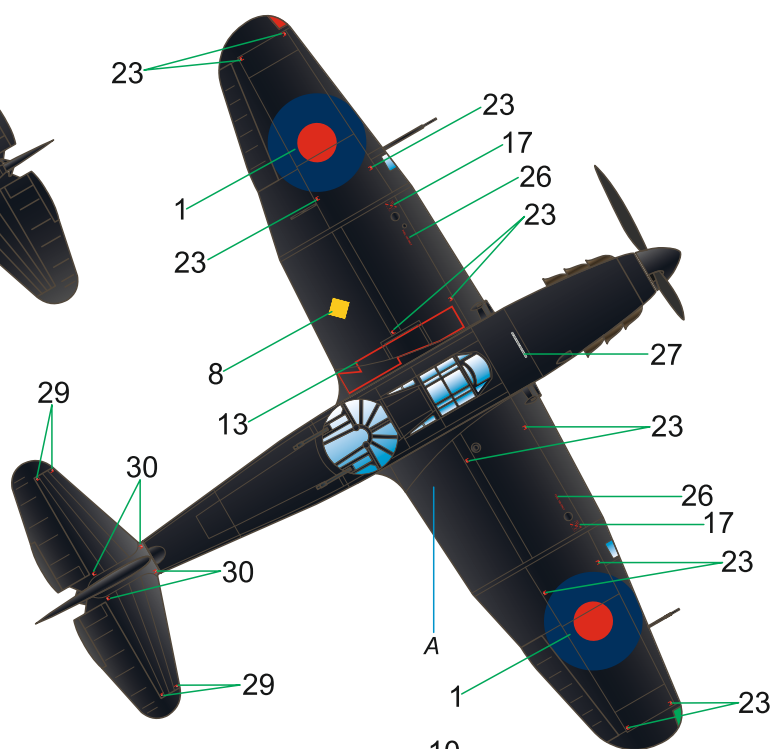
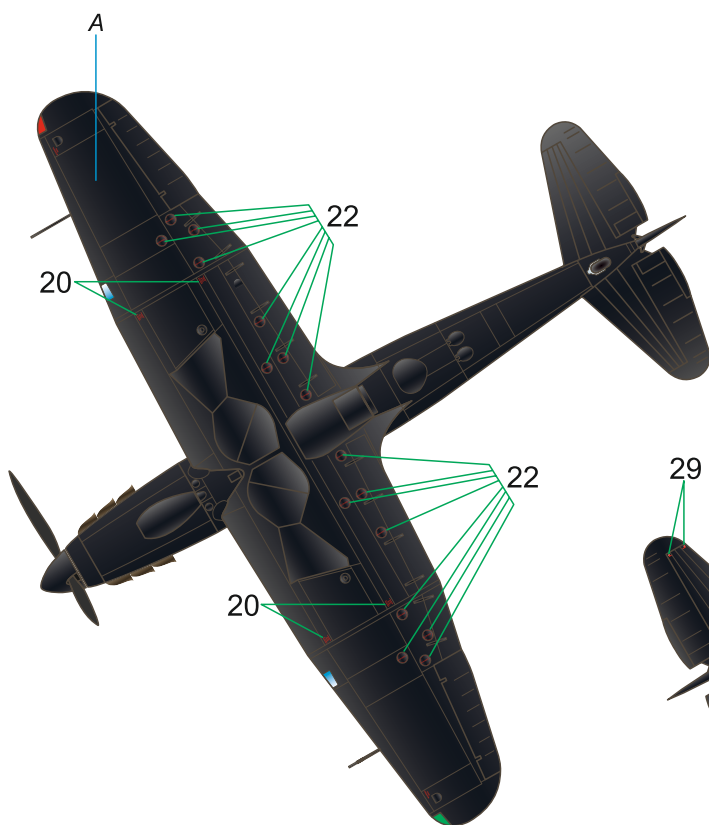
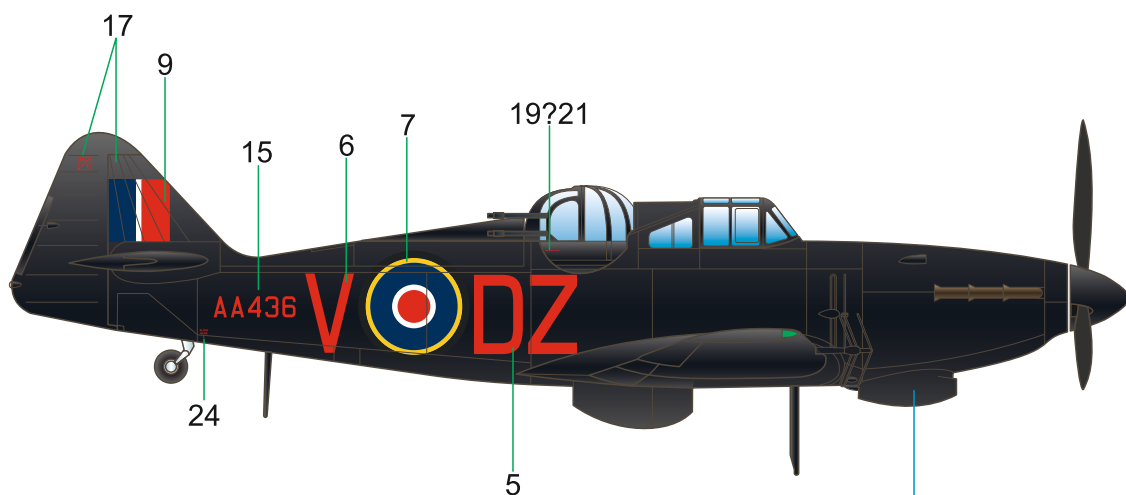

A Black
Černá
H12/C33

B Tire Black
Barva pneu
H77/C137

C Yellow
Žlutá
H329/C329

D Aluminium
Hliník
H8/C8

E Interior Grey-Green
Interierová šedozelená
H334/C334

1/72 TEMPEST Mk.V



3D PRINTED AND RESIN SETS FOR AIRFIX KIT

Q72413
Tempest/Typhoon
Early type Wheels



Q72414
Tempest Late Type Wheels



P72011
Tempest Mk.V Exhausts

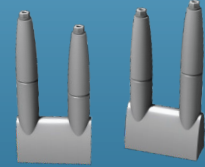
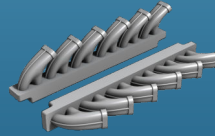

P72009 Tempest Mk.V
Early Gun Barrels

P72008 Tempest Mk.V Engine
and Fuselage Tanks

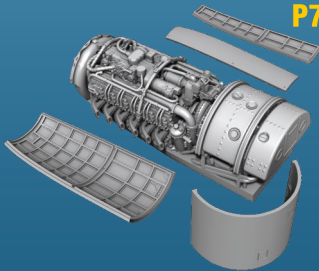

P72010

Tempest Mk.V Gun Sight and
Seat Correction Set

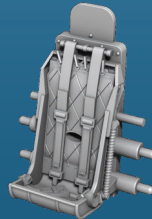

P72021

Tempest
Bombs and racks

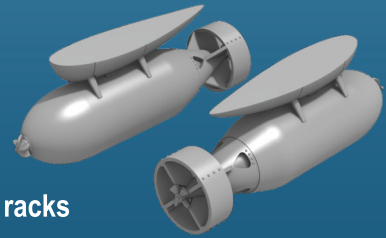

1/72 TYPHOON MK.I 3D PRINTED SETS FOR AIRFIX KIT

P72012
Typhoon Mk.I Engine

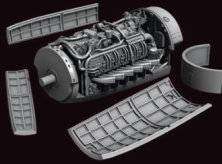

P72013
Typhoon Mk.I Gun Sight
and Seat Correction Set



P72014
Typhoon Mk.I
Three-blade Propeller

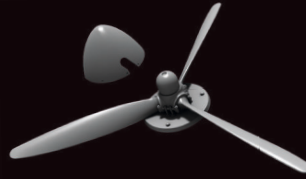

P72015
Typhoon Mk.I Gun Bays

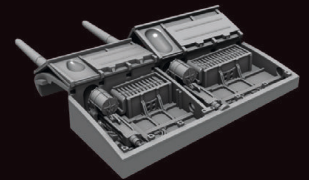

P72016
Typhoon Mk.I
Standard Exhausts

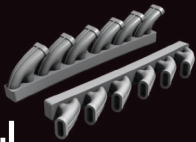

P72017
Typhoon Mk.I
Late Type
Shrouded Exhausts



P72022
Typhoon Mk.I
Tailwheel
w/Leg



F72402
Tempest Pilot, Dog and Mechanic
with Accumulator Trolley

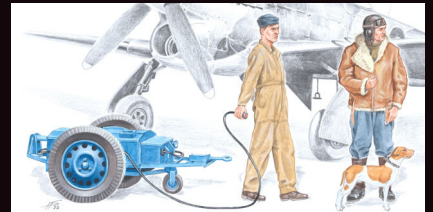

H1020 Razor Saw Profi Set



A new type handle for
our razor saws.

Also contains H1018 and H1019 spare saws.

H1018
Triangle Razor Saw (1pc)



H1019
Multi-Shift Razor Saw (1pc)





SH72484
Kittyhawk Mk.IV
'Over the Mediterranean and the Pacific' 1/72

Special MASK

- M72015** P-40E/K/Kittyhawk Mk.Ia/Mk.III Mask
- M72016** P-40N/Kittyhawk Mk.IV Mask
- M72026** P-40M Warhawk/Kittyhawk Mk.III Mask



SH72367
P-40D Warhawk/Kittyhawk Mk.I
'Four Guns' 1/72

P-40 Warhawk CMK RESIN SETS for Special Hobby kits

 Q72293 P-40E/F/K/L/M and N-1 Seat	 Q72294 P-40N-5 through N-40 Seat	 Q72299 P-40E, F, K, L, M and N-1 Seat with Belts	 Q72301 P-40 Cockpit Sidewalls and Control Column	 Q72295 P-40 Wheels Diamond Tread	 Q72296 P-40 Wheels Block Tread
 Q72300 P-40N-5 through N-40 Seat with Belts	 Q72302 Kittyhawk I, Ia, II, IIa and III Seat with Sutton Harness	 Q72303 Kittyhawk IV Seat with Sutton Harness	 Q72309 P-40E-N Control Column (3 pcs)	 Q72297 P-40 Wheels Cross Tread	 Q72298 P-40 Wheels Diamond and Hole Tread
 7386 P-40 Control Surfaces	 7389 P-40E/K/M/N Armament Set				
 7387 P-40 Undercarriage Set	 7388 P-40 Engine Set	 7390 P-40N Engine Set	 F72344 RAF Pilot Sitting in Cockpit with Monkey + 2 Mechanics, Western Desert		

Special
HOBBY



1/72 SH72498



Gloster Meteor Mk.4 'RAF and KLu'

Special
HOBBY

1/72 SH72408



Fairey Barracuda Mk.III 'ASV Mk.XI Radar'

Special
HOBBY

1/72 SH72408



Short Sunderland Mk.I/II 'The Flying Porcupine'

Special
HOBBY



facebook.com/specialhobby | WWW.SPECIALHOBBY.EU | WWW.CMKKITS.COM

