

4491 Henschel Hs 129B Wheels
1/48 for Hasegawa and Hobby 2000 kits

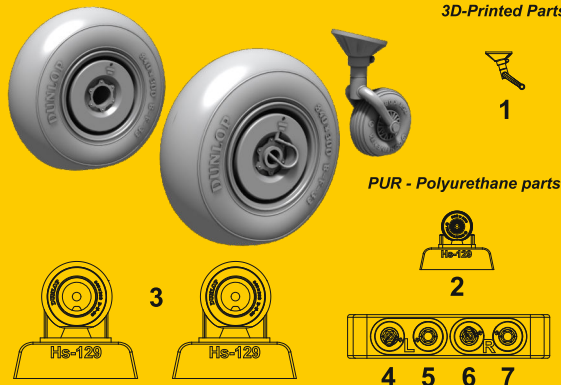

3D-Printed Parts



PUR - Polyurethane parts

© Special Hobby 2025

Resinové díly ohnuté popř. pokroutené vlivem teplotních změn a stárnutí materiálu, mohou být narovnány do požadovaného tvaru pomocí proudu teplé vody nebo vzduchu (fén na vlasy). Ohnuté 3D tisky narovnejte ponořením do horké vody, srovnejte je a zchladte studenou vodou. K lepení použít kyanoakrylátové lepidlo! Kontaktní plochy doporučujeme před lepením odmastit. Různé drátky a tyčinky nejsou přiloženy.

Parts slightly distorted and bent owing to temperature changes or due to material aging can be straightened to requested shape by hot water or hot air jet (hair dryer). This process can be repeated till result is entirely satisfactory. You can also correct bent 3D printed parts: put them into hot water, straighten them and cool them in cold water. For best result use cyanoacrylate glue! Ungreasing contact areas is recommended before gluing. Wires and rods not included.

Special Hobby offer as well:

4415 German WWII Aircraft Maintenance Toolbox

4459 Hs 129B-2/R2-30mm MK 103 cannon with pod

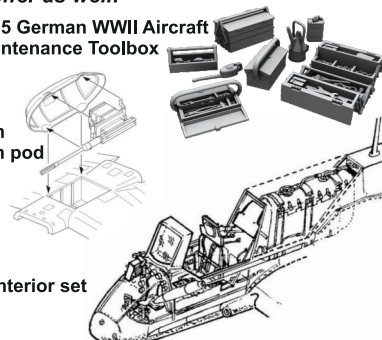

4066 Hs 129B - interior set

and other 1/48 Hs 129 sets, more at www.specialhobby.eu

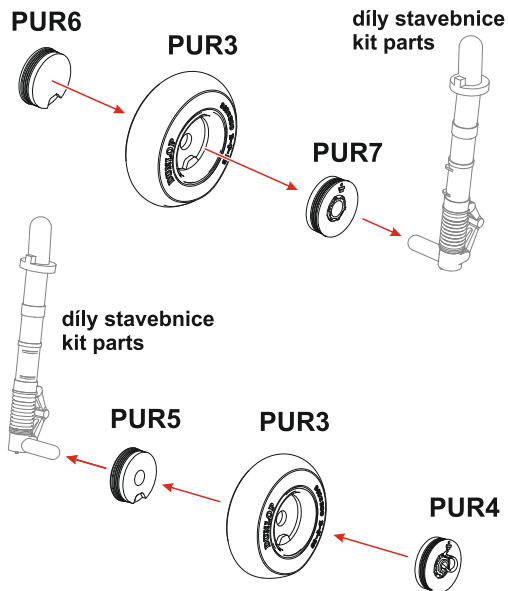

Visit our official website and e-shop at

www.specialhobby.eu
www.facebook.com/specialhobby/

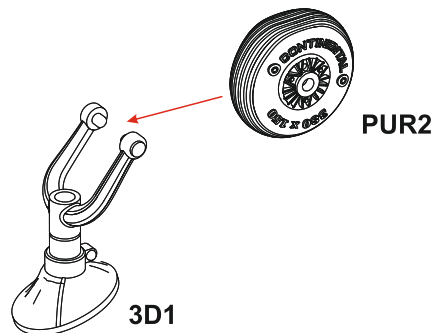

Special Hobby, Mezileší 718, Praha 9, 193 00, Czech Republic
 e-mail: office@specialhobby.eu