

6013
1/35

M60D with Sagami Mount
(2 pcs.) for UH-1B Huey
for Trumpeter kits

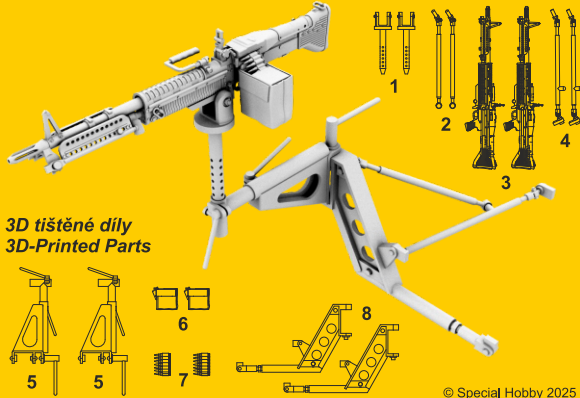

3D tištěné díly
3D-Printed Parts

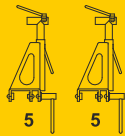

© Special Hobby 2025

6013
1/35

M60D with Sagami Mount
(2 pcs.) for UH-1B Huey
for Trumpeter kits

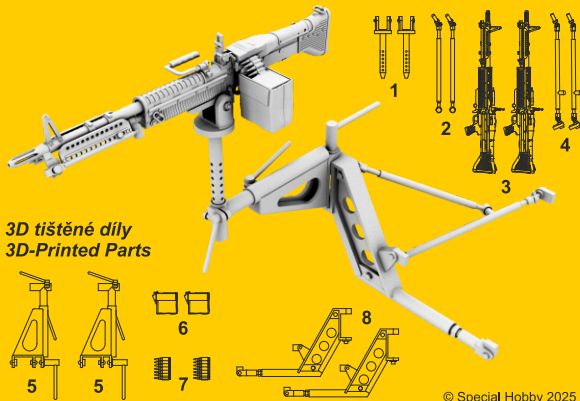

3D tištěné díly
3D-Printed Parts

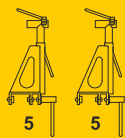

© Special Hobby 2025

6013
1/35

M60D with Sagami Mount
(2 pcs.) for UH-1B Huey
for Trumpeter kits

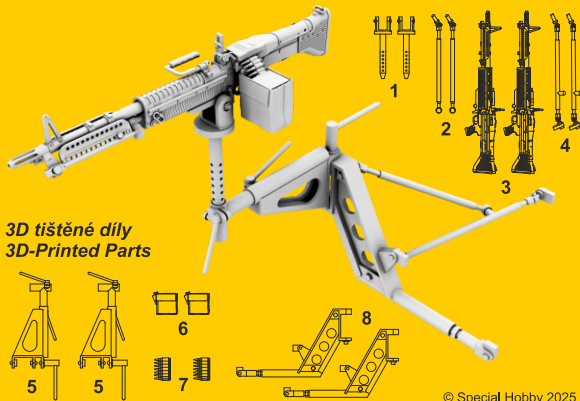

3D tištěné díly
3D-Printed Parts

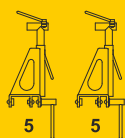

© Special Hobby 2025

Resinové díly ohnuté popř. pokroucené vlivem teplotních změn a stárnutí materiálu, mohou být narovnány do požadovaného tvaru pomocí proudu teplé vody nebo vzduchu (fén na vlasy). Ohnuté 3D tisky narovnejte ponořením do horké vody, srovnajte je a zchladte studenou vodou. K lepení použít kyanoakrylátové lepidlo! Kontaktní plochy doporučujeme před lepením odmastit. Různé drátky a tyčinky nejsou přiloženy.

Parts slightly distorted and bent owing to temperature changes or due to material aging can be straightened to requested shape by hot water or hot air jet (hair dryer). This process can be repeated till result is entirely satisfactory. You can also correct bent 3D printed parts: put them into hot water, straighten them and cool them in cold water. For best result use cyanoacrylate glue! Ungreasing contact areas is recommended before gluing. Wires and rods not included.

Special Hobby offer as well:

6012
1/35 UH-1B Huey
Exhaust

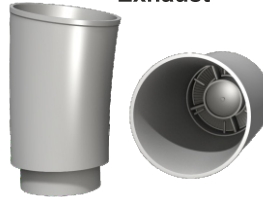

Special Hobby, Mezileší 718, Praha 9, 193 00, Czech Republic
e-mail: office@specialhobby.eu

6009
1/35 Vietnam Era
US Helicopter
Pilot Helmet
(2 pcs.)



Resinové díly ohnuté popř. pokroucené vlivem teplotních změn a stárnutí materiálu, mohou být narovnány do požadovaného tvaru pomocí proudu teplé vody nebo vzduchu (fén na vlasy). Ohnuté 3D tisky narovnejte ponořením do horké vody, srovnajte je a zchladte studenou vodou. K lepení použít kyanoakrylátové lepidlo! Kontaktní plochy doporučujeme před lepením odmastit. Různé drátky a tyčinky nejsou přiloženy.

Parts slightly distorted and bent owing to temperature changes or due to material aging can be straightened to requested shape by hot water or hot air jet (hair dryer). This process can be repeated till result is entirely satisfactory. You can also correct bent 3D printed parts: put them into hot water, straighten them and cool them in cold water. For best result use cyanoacrylate glue! Ungreasing contact areas is recommended before gluing. Wires and rods not included.

Special Hobby offer as well:

6012
1/35 UH-1B Huey
Exhaust

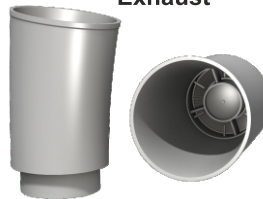

Special Hobby, Mezileší 718, Praha 9, 193 00, Czech Republic
e-mail: office@specialhobby.eu

6009
1/35 Vietnam Era
US Helicopter
Pilot Helmet
(2 pcs.)



Resinové díly ohnuté popř. pokroucené vlivem teplotních změn a stárnutí materiálu, mohou být narovnány do požadovaného tvaru pomocí proudu teplé vody nebo vzduchu (fén na vlasy). Ohnuté 3D tisky narovnejte ponořením do horké vody, srovnajte je a zchladte studenou vodou. K lepení použít kyanoakrylátové lepidlo! Kontaktní plochy doporučujeme před lepením odmastit. Různé drátky a tyčinky nejsou přiloženy.

Parts slightly distorted and bent owing to temperature changes or due to material aging can be straightened to requested shape by hot water or hot air jet (hair dryer). This process can be repeated till result is entirely satisfactory. You can also correct bent 3D printed parts: put them into hot water, straighten them and cool them in cold water. For best result use cyanoacrylate glue! Ungreasing contact areas is recommended before gluing. Wires and rods not included.

Special Hobby offer as well:

6012
1/35 UH-1B Huey
Exhaust

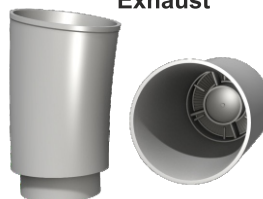

Special Hobby, Mezileší 718, Praha 9, 193 00, Czech Republic
e-mail: office@specialhobby.eu

6009
1/35 Vietnam Era
US Helicopter
Pilot Helmet
(2 pcs.)



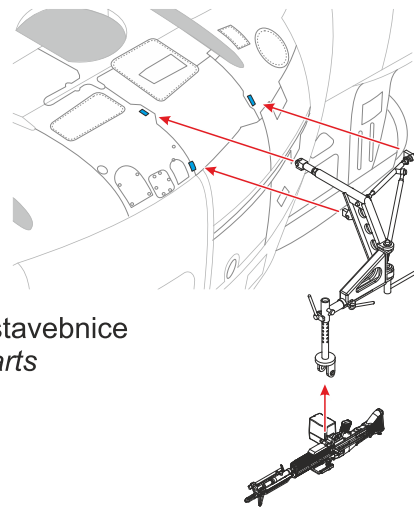
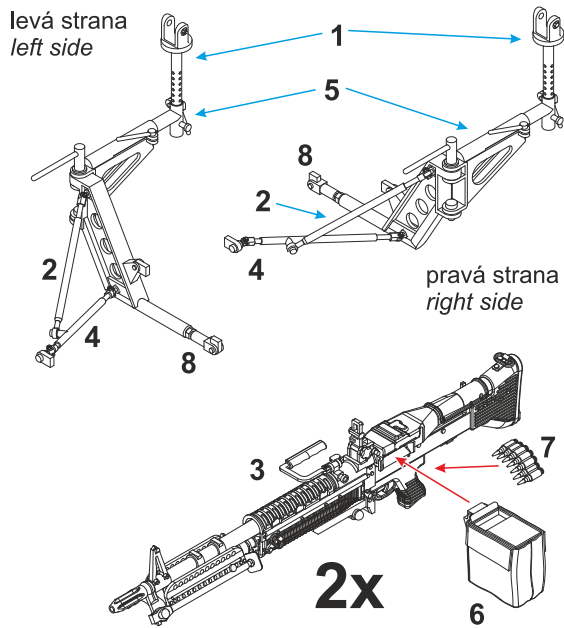

díly stavebnice
kit parts

symetrická montáž
symmetrical assembly

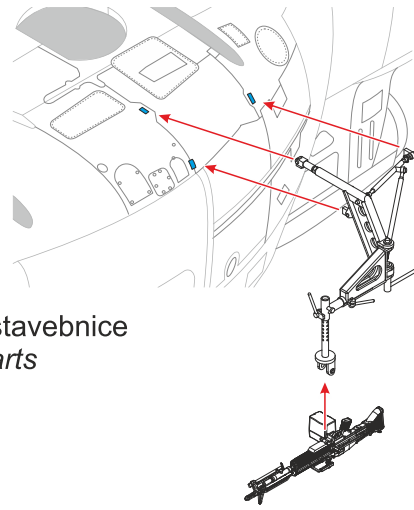
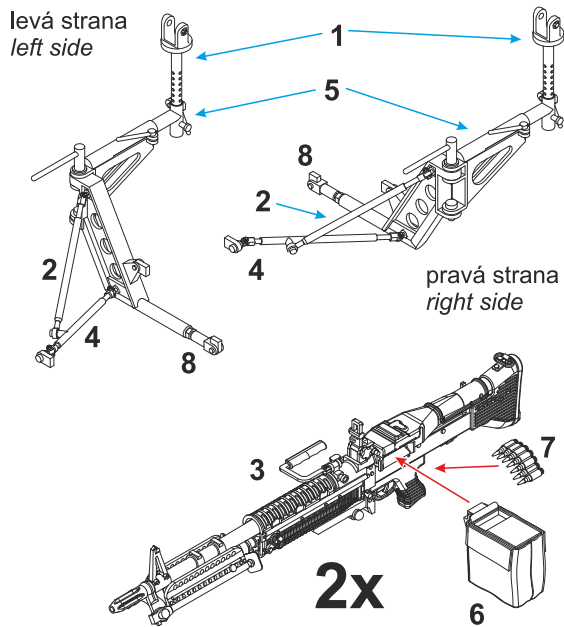

díly stavebnice
kit parts

symetrická montáž
symmetrical assembly

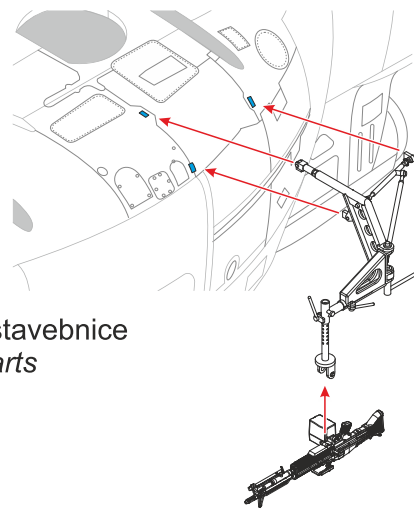
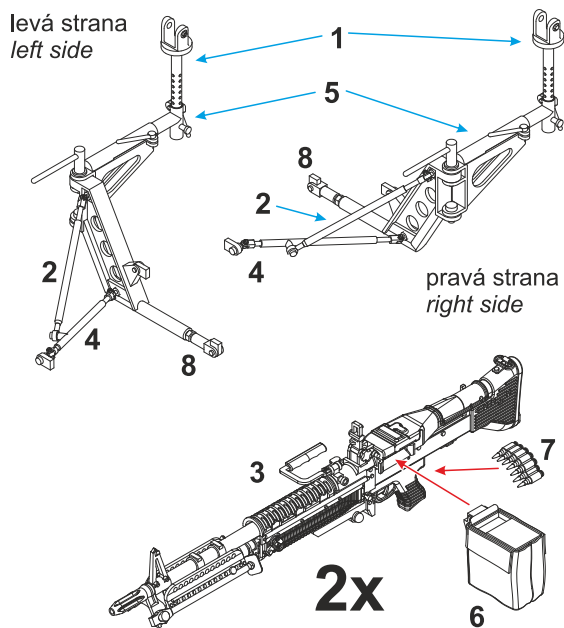

díly stavebnice
kit parts

symetrická montáž
symmetrical assembly