

**P72046** **Mosquito**  
**1/72** **Undercarriage Legs**  
*for Special Hobby kits*

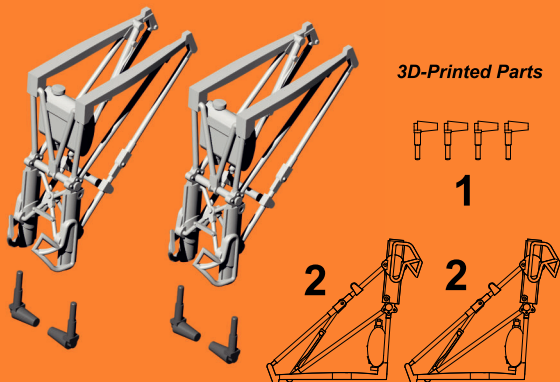

Special Hobby 2025

Resinové díly ohnuté popř. pokroucené vlivem teplotních změn a stárnutí materiálu, mohou být narovnané do požadovaného tvaru pomocí proudu teplé vody nebo vzduchu (fén na vlasy). Ohnuté 3D tisky narovnejte ponořením do horké vody, srovnějte je a zchlaďte studenou vodou. K lepení použít kyanoakrylátové lepidlo! Kontaktní plochy doporučujeme před lepením odmastit.  
 Různé drátky a tyčinky nejsou přiloženy.

*Parts slightly distorted and bent owing to temperature changes or due to material aging can be straightened to requested shape by hot water or hot air jet (hair dryer). This process can be repeated till result is entirely satisfactory. You can also correct bent 3D printed parts: put them into hot water, straighten them and cool them in cold water. For best result use cyanoacrylate glue! Ungreasing contact areas is recommended before gluing. Wires and rods not included.*

**Special Hobby offer for 1/72 Mosquito kits as well:**

**P72041**

**Mosquito Dinghy Box**



**P72042**

**Mosquito Exhausts**  
 (PR and Bombers with two stage Merlins)

**7523**

**Mosquito Mainwheels and Tailwheel w/Leg**



**more at**  
[www.specialhobby.eu](http://www.specialhobby.eu)

Special Hobby, Mezilesí 718, Praha 9, 193 00, Czech Republic  
 e-mail: [office@specialhobby.eu](mailto:office@specialhobby.eu)

**1**

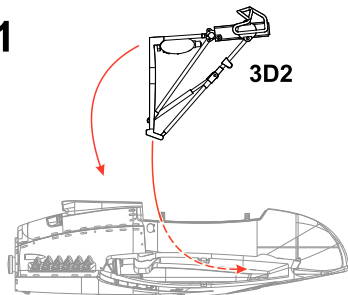

**2**

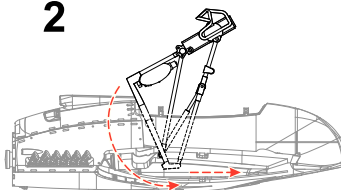

**3**

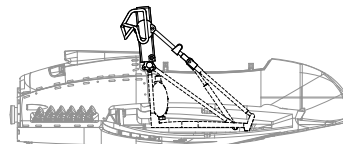

**díly stavěnice**  
**kit parts**

vyzkoušet usazení na sucho  
*dry fit first*

**3D1**

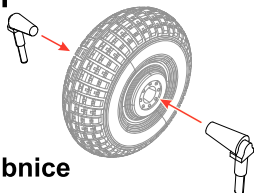

**díl stavěnice**  
**kit part**

**3D1**

**symetrická montáž**  
**symmetrical assembly**

