

ASSEMBLY/SESTANA ... 1
 ASSEMBLY/SESTANA ... 2

CP 1

ASSEMBLY/SESTAVA ... 4

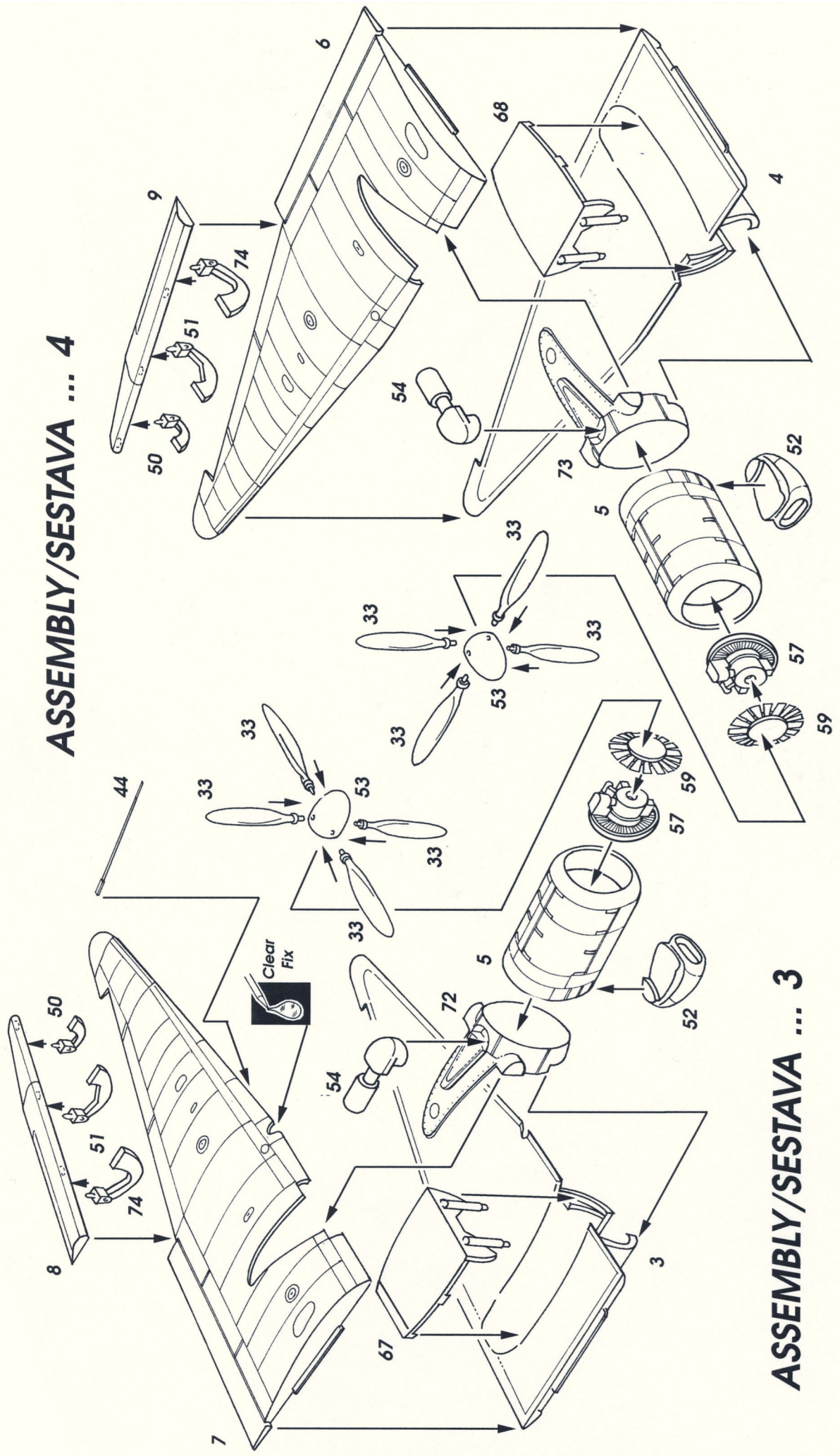

ASSEMBLY/SESTAVA ... 3

ASSEMBLY/SESTAVA ... 6

Right wing/pravé křídlo

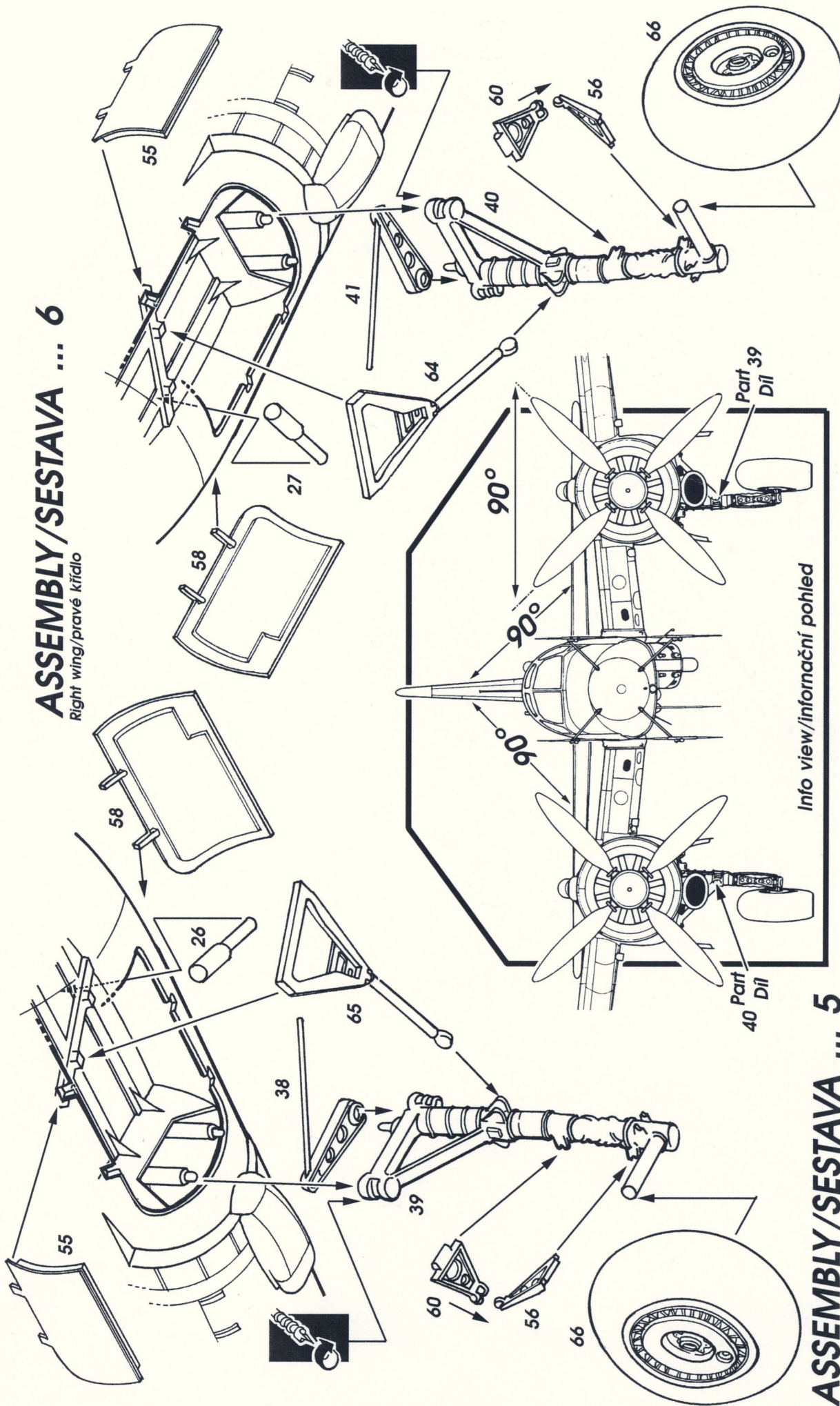

Info view/informační pohled

ASSEMBLY/SESTAVA ... 5

ASSEMBLY/SESTAVA ...7

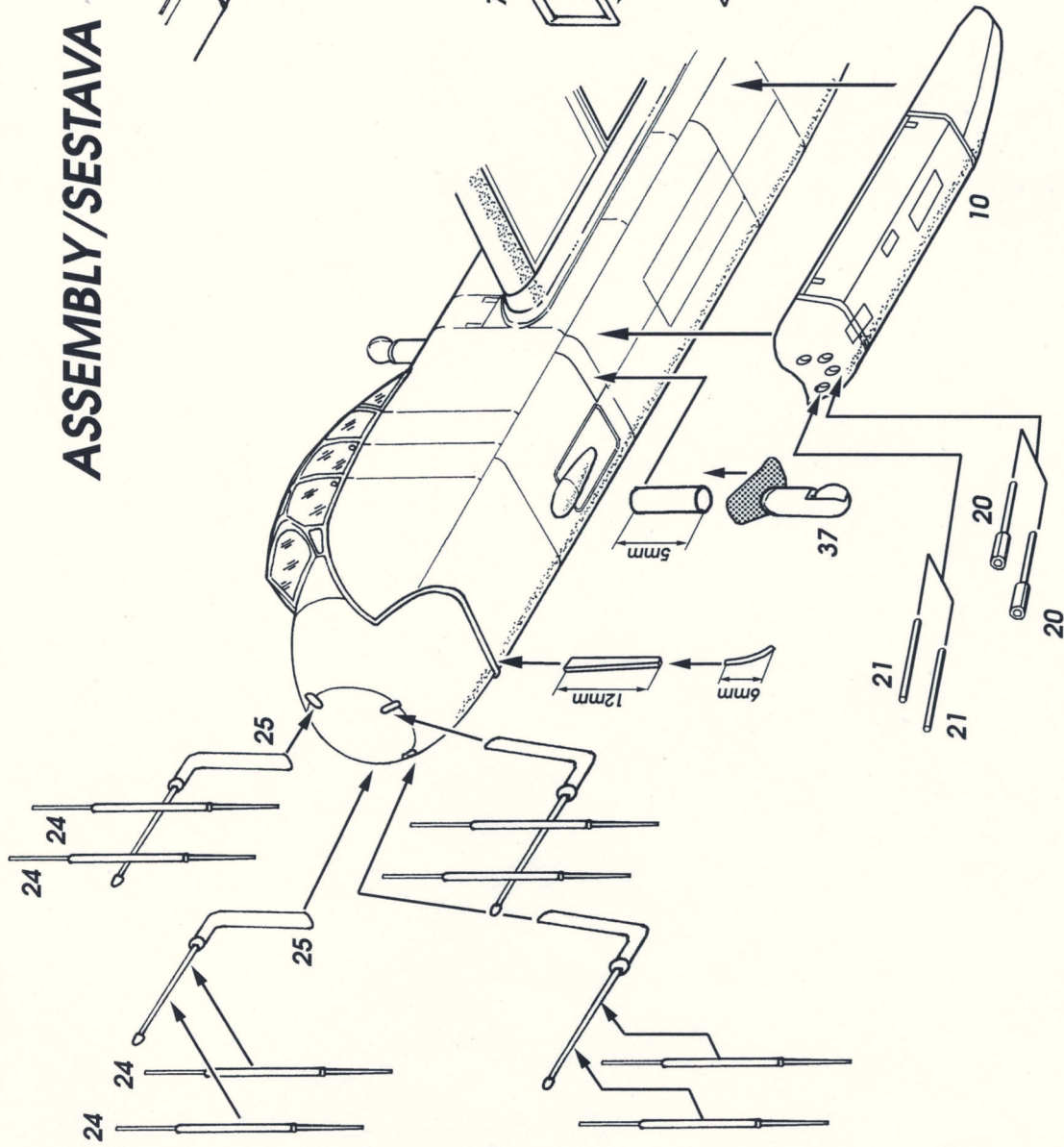

ASSEMBLY/SESTAVA ... 8

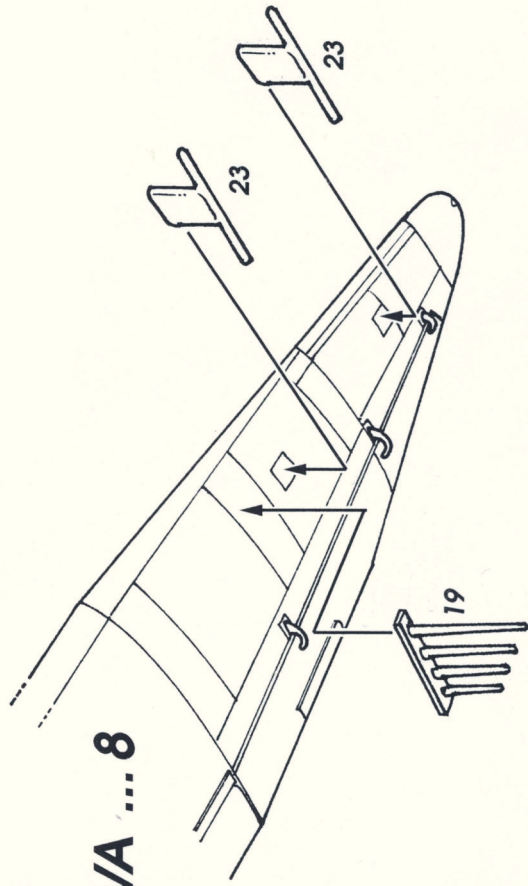

ASSEMBLY/SESTAVA ...9

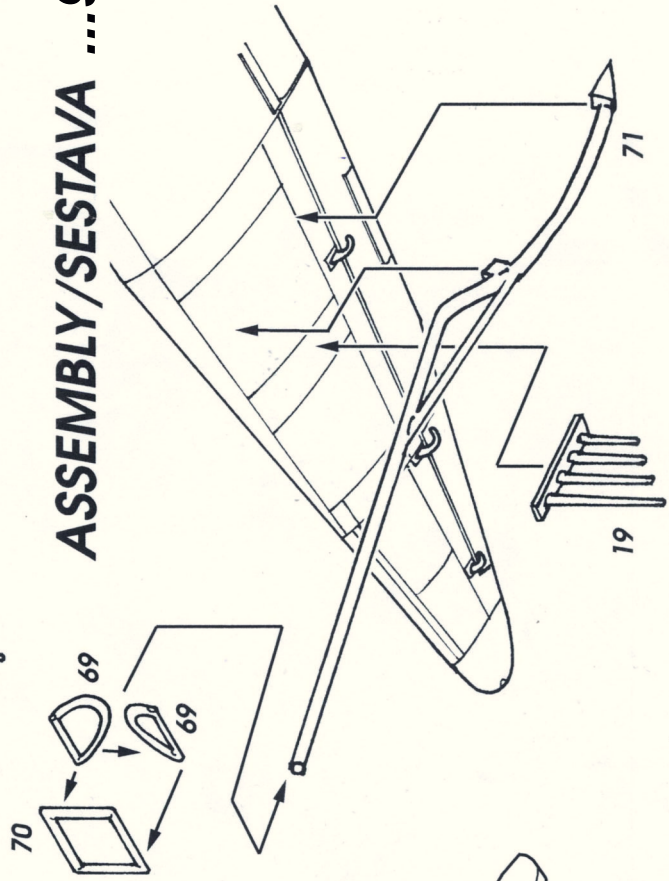

Junkers Ju 388V2 (J-0)

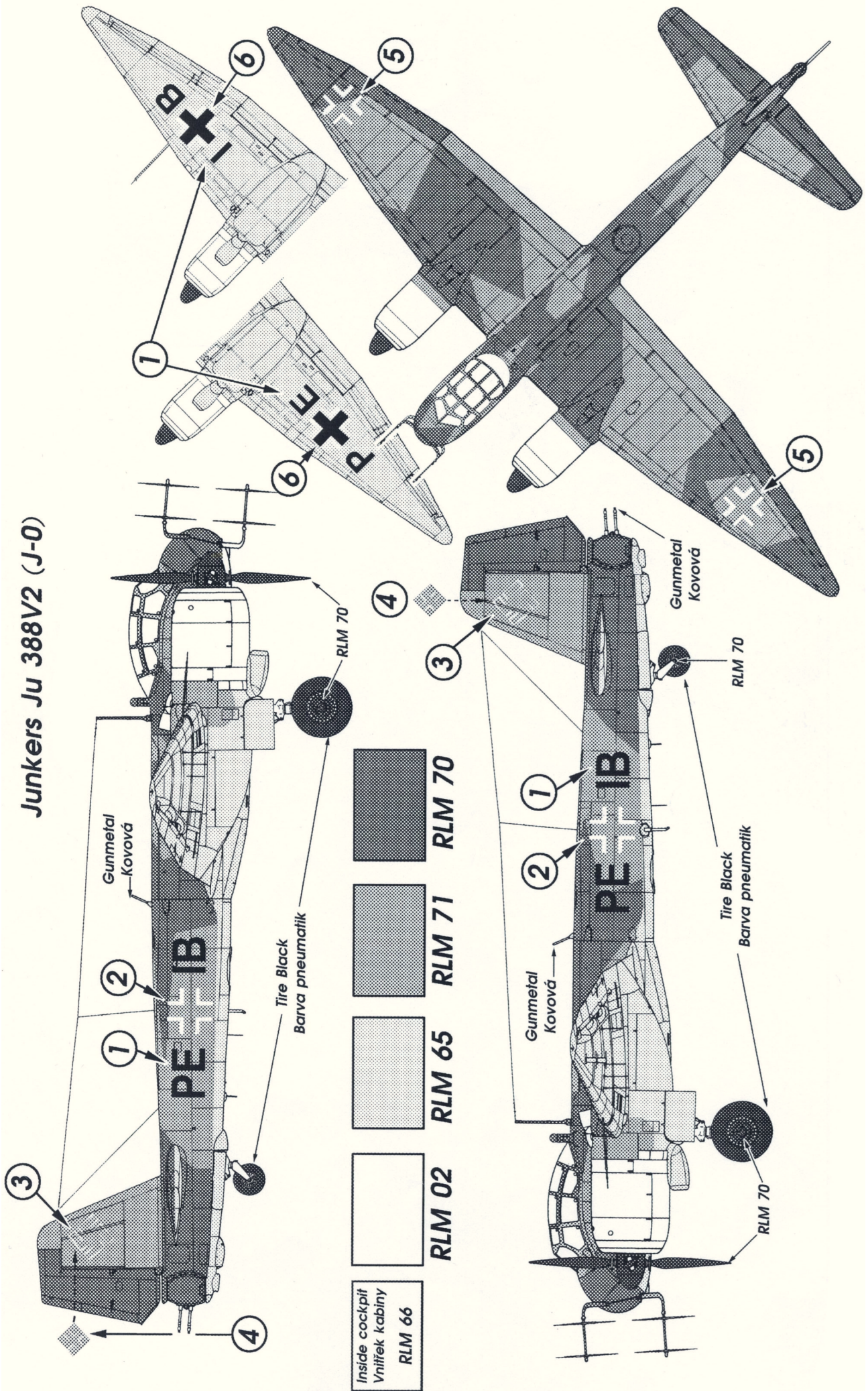

Inside cockpit
Vnitřek kabiny
RLM 66

RLM 02

RLM 65

RLM 71

RLM 70

Gunmetal Kovová

Tire Black
Barva pneumatik

Tire Black
Barva pneumatik

Gunmetal
Kovová

RLM 70

RLM 70

4

3

1

2

2

1

3

4

6

1

6

5

6

5

5

Excellent 1/48 plastic kits, resin and 3D printed sets and kits by Special Hobby

1/48
SH48212

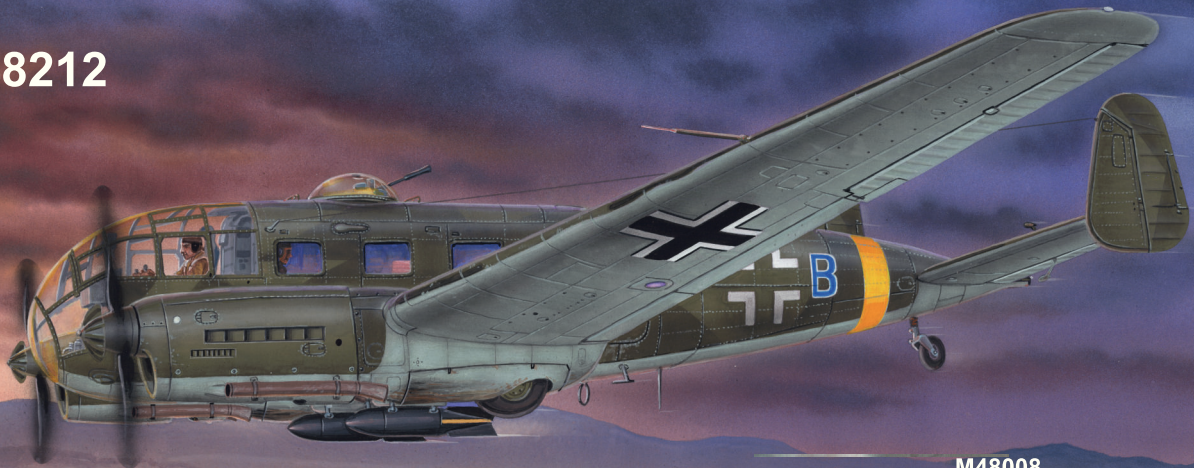

Siebel Si 204E
'German Night Bomber & Trainer'

M48008
Siebel Si 204E/Aero C-3B
Bomber MASK

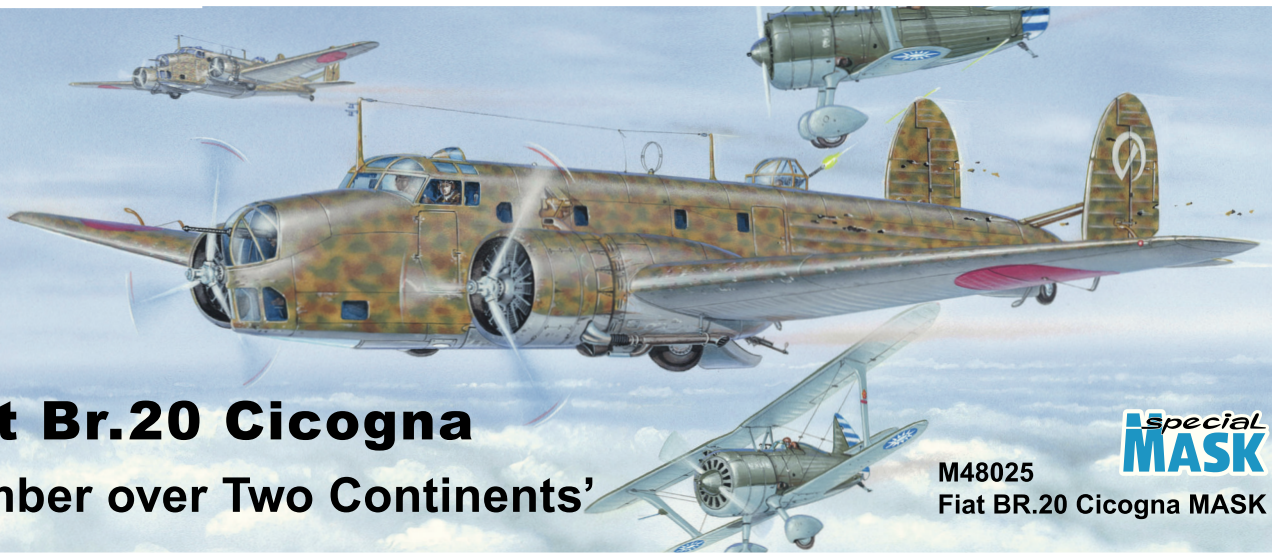

Fiat Br.20 Cicogna
'Bomber over Two Continents'

M48025
Fiat BR.20 Cicogna MASK



1/48
SH48206



Reggiane Re.2005 Sagittario
'Ultimate Italian WWII Fighter'

Q48364 1/48
Main Wheels



Q48365 1/48
Tailwheel with
Strengthened
Leg



Q48366 1/48
Supercharger
Air Intake



Q48367 1/48
Exhausts



M48002
Reggiane Re.2005
MASK



more at www.specialhobby.eu

Excellent 1/48 plastic kits, resin and 3D printed sets and kits by Special Hobby

1/48 **CMK** sets for Siebel Si 204/Aero C-3



F48357
Mechanic
(Engine Repair)



F48358
Airman (Cleaning
Canopy Glazing)



F48359
Rigger (Prop
Maintenance)



F48367
Luftwaffe WW2 /
CS Post-War
Aircraft Mechanic



Q48352
Wheels



Q48353
Pilots' Seats



4386
Engine



Q48354
Prop Spinners



4415
German WWII Aircraft
Maintenance Toolbox

Focke Wulf Fw P.II

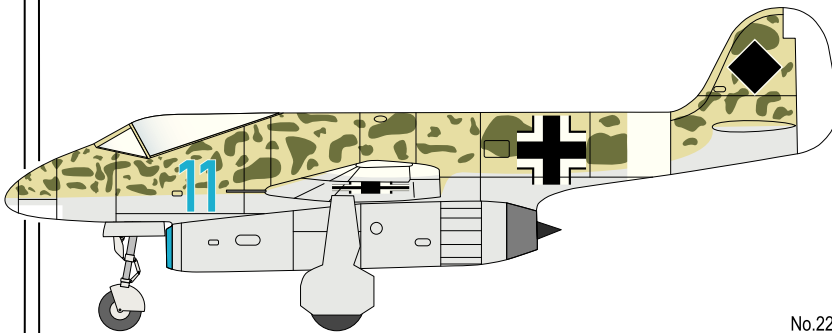

Resinový model obsahující podvozkové nohy odlité z bílého kovu.
Resin kit contains white metal undercarriage legs.

No.224
1:48

Made in Czech Republic

Heinkel He 100 V-8



"World Speed Record"

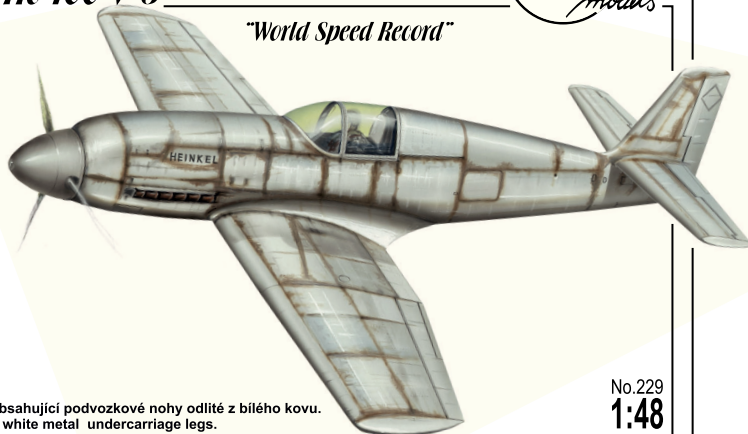

Resinový model obsahující podvozkové nohy odlité z bílého kovu.
Resin kit contains white metal undercarriage legs.

No.229
1:48

Made in Czech Republic

more at www.specialhobby.eu