

Umístění náradí na korbě zvolte dle vlastního uvážení nebo podle fotografií / Location of tools on the hull choose according to you own consideration or photographs.

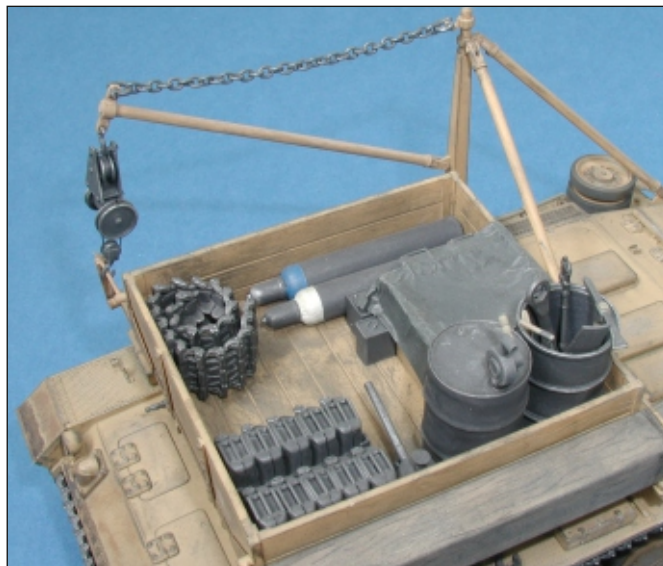

Doporučujeme další konverzní sady / Recommended next conversion sets :

- 3010 VW typ 21 Kastenwagen
- 3015 OT 34 - 34/76 mod.43
- 3019 GMC CCKW 353 fuel tank
- 3036 M - 151 Vietnam armoured version
- 3037 M - 966 IDF
- 3039 Panther G Ersatz M-10

[www.cmkkits.com](http://www.cmkkits.com)  
[www.specialhobby.eu](http://www.specialhobby.eu)  
[www.facebook.com/specialhobby/](http://www.facebook.com/specialhobby/)

Díly ohnuté popř. pokroucené vlivem teplotních změn a stárnutí materiálu, mohou být narovnané do požadovaného tvaru pomocí proudu teplé vody nebo vzduchu (fén na vlasy).  
 - pro lepení použijte vteřinová lepidla  
 - kontaktní plochy doporučujeme před lepením odmastit  
 Parts slightly distorted and bended owing to temperature changes or due to material ageing can be straightened to requested shape by hot water or hot air jet. (hair dryer) This process can be repeated till result is entirely satisfactory.  
 - For best gluing use cyanoacrylate glue.  
 - Degreasing contact areas is recommended before gluing.



Konverzní doplňková sada  
 Conversion accessory set

No 3044

1/35

# Bergepanzer III

conversion set  
 for TAMIYA / REVELL

PUR (polyuretan parts) 1

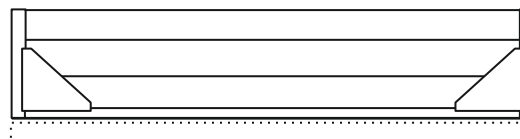

2 (2x)

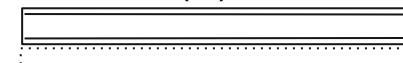

4



6

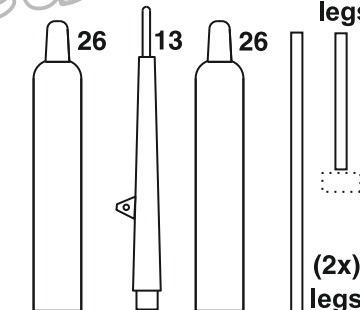

legs

(2x) legs

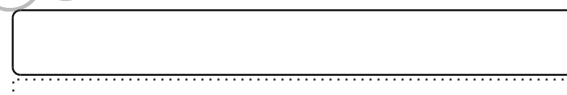

7

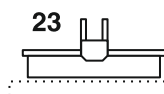

23



18



24

5

24

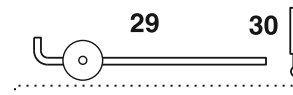

29



30

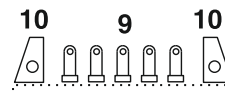

10

9

10



19

17

16

20

11

12

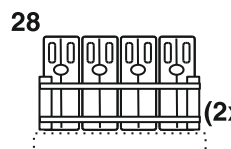

28



3

14

8

3

(2x)

22

27

15

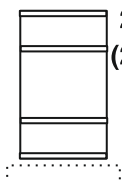

21

(2x)

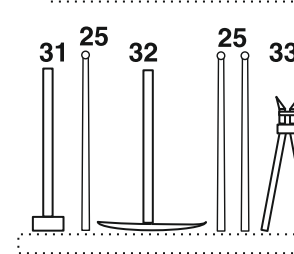

31

25

32

25

33

Chain

PP (photo etched parts)

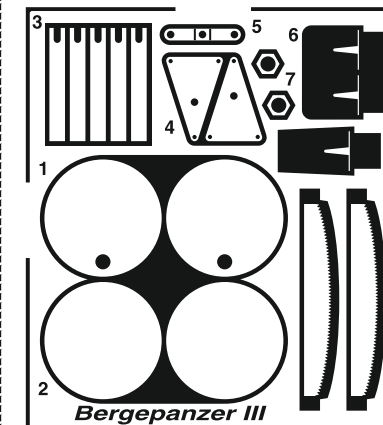

K lepení použít kyanoakrylátové lepidlo !  
 For gluing use cyanoacrylate glue !

Bergepanzer III

### 1 Sestavení vzpěr korbě / Hull struts assembly

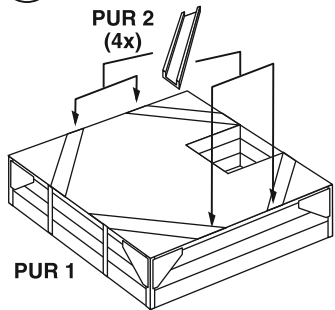

Díl PUR 2 zkrátte dle výkresu  
Shorten part PUR 2 according to drawing.

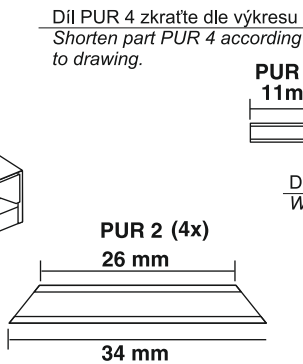

### 2 Sestavení držáků břemen / Load holders assembly

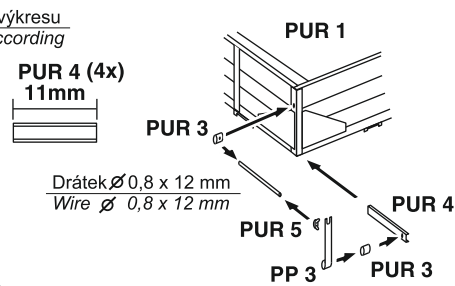

### 4 Zhotovení ramen jeřábu / Crane arm manufacturing

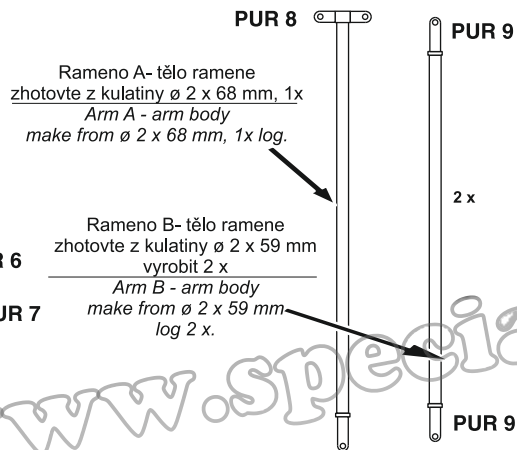

### 3 Montáž břemen ke korbě / Charge assembly to hull

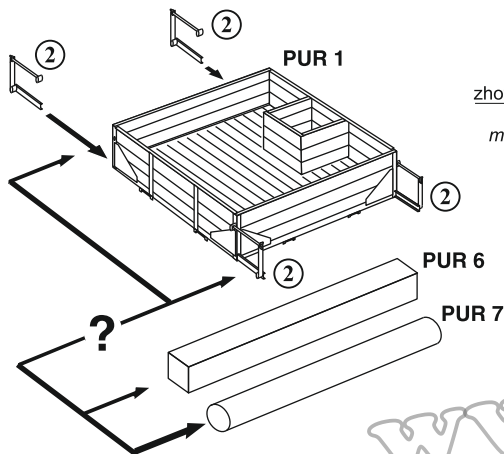

### 5 Montáž kování / Fittings mounting

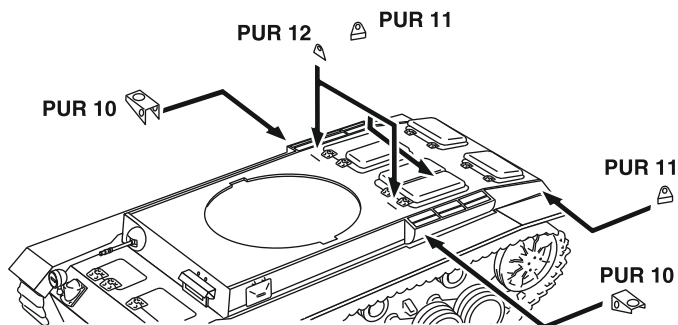

### 6 Sestavení kočky jeřábu / Crane trolley assembly

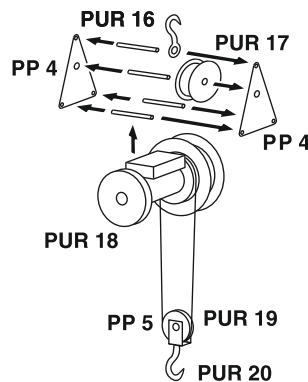

### 7 Sestavení korbě a jeřábu na tělo vozidla / Hull and crane assembly on vehicles body

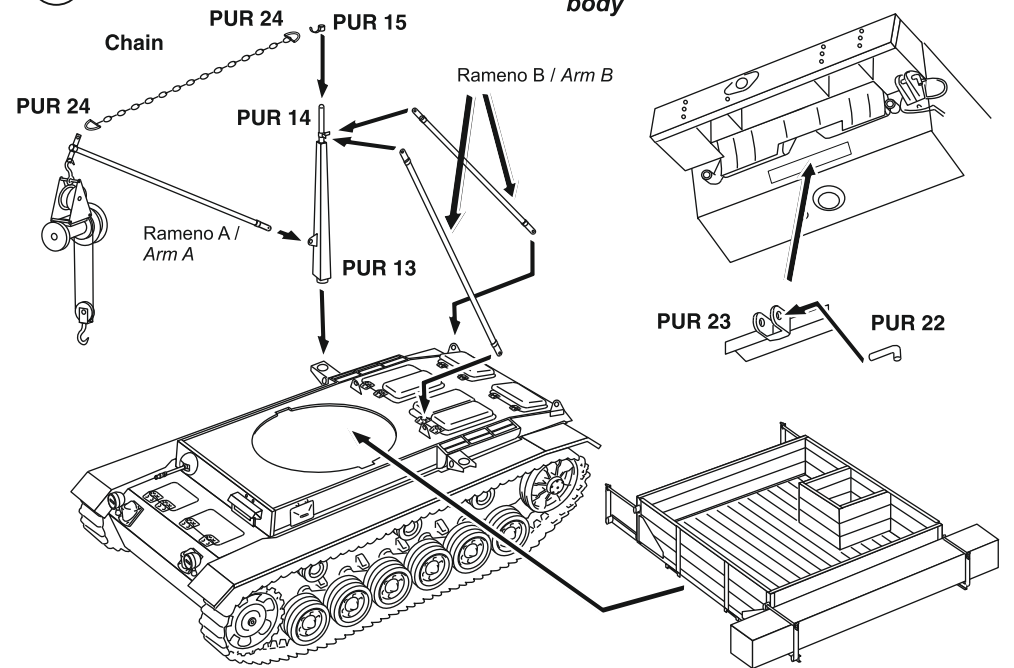

### 8 Sestavení příslušenství / Accessories assembly

