

## IMAM Ro.37

### NÁVOD / INSTRUCTIONS

#### CZ – Historie

Regia Aeronautica na počátku třicátých let minulého století používala průzkumné a pozorovací IMAM Ro.1 (licenčně vyráběné Fokker C.V). Byla s nimi spokojena, ale když firma IMAM nabídla nový dvouplošný letoun, zkonstruovaný Ing. Giovannim Galazzem, rozhodla se nabídku přijmout. Po vyzkoušení prototypu byla v roce 1934 zahájena sériová výroba. Sériové stroje byly vyráběny jak továrnou IMAM, tak továrnami A.V.I.S. a Caproni Taliedo v několika sériích. Všechny série Ro.37 byly poháněny motory Fiat A.30. Lišily se ale použitými typy chladičů a dřevěnými či kovovými vrtulemi. Regia Aeronautica projevila zájem i o verzi poháněnou hvězdicovým motorem Piaggio P.IX. Tato verze byla označena Ro.37bis a vyráběna a používána souběžně. Romeo Ro.37 a 37bis se staly hlavními taktickými pozorovacími a průzkumnými letouny Regia Aeronautica a zůstaly jimi až do italské kapitulace v roce 1943. Do 25. 8. 1943, kdy Itálie kapitulovala, bylo vyrobeno celkem 621 strojů obou typů, z toho 325 kusů Ro 37bis. Prvního bojového nasazení se Ro.37 a Ro.37bis dočkaly během italského útoku na Habeš (Etiopii). Nasazeny byly i ve španělské občanské válce. Tam bojovaly v rámci Aviazione Legionaria i španělského nacionalistického letectva. Po vypuknutí druhé světové války byly nasazeny na všech bojištích, kde bojovala Regia Aeronautica s výjimkou východní fronty a bojů proti Velké Británii. V době vstupu Itálie do války měla Regia Aeronautica 483 kusů Ro 37 obou verzí, z toho 200 Ro 37 bis, z čehož ovšem jen asi 100 strojů obou verzí bylo letuschopných. Dočkaly se tak nasazení nad Balkánem, severní Afrikou i nad Itálií. Na základě konstrukce Ro.37/37bis byly také zkonstruovány průzkumný katapultovací plovákový IMAM Ro.43 a stíhací plovákový IMAM Ro.44.

Vzhledem k dobrým výkonům a alternativní nabídce řadového a hvězdicového motoru byly Ro.37 a Ro.37bis úspěšně exportovány. V Evropě byly používány Maďarským královským letectvem, Rakouským letectvem a Španělským nacionalistickým letectvem. Letouny Ro.37bis se dostaly i mimo Evropu, létaly v Afghánistánu a také v Paraguai a Ecuadoru.

Rozpětí: 11,08 m, délka: 8,62 m, max. rychlost: 325, dolet: 1 650 km, výzbroj: 2× pevný kulomet Breda – SAFAT ráže 12,7 mm, kulomet střelce Lewis nebo Breda ráže 7, 7 mm, 12 pum o hmotnosti 12 nebo 15 kg.

#### EN – History

In the early 1930s, the Italian Regia Aeronautica operated IMAM Ro.1 (licence-built Fokker C.V) reconnaissance and observation biplanes. The military were quite happy with the type, however when IMAM offered a new biplane type designed by Giovanni Galasso, the decision was taken to acquire this new aircraft. Following the prototype's successful test flights, the production was commenced in 1934 by IMAM and several production series were also built by A.V.I.S and Caproni Taliedo. The Ro.37 was powered by an in-line Fiat A.30 engine and fitted with various styles of radiators and either wooden or metal propellers could be used. The Italian military also showed interest for a version fitted with a Piaggio P.IX radial engine. This version was known as the Ro.37bis and was produced along the inline-engined type. The Ro.37 and 37bis became the main observation and reconnaissance types of the Regia Aeronautica and were kept in service until Italy surrendered on 25 August 1943. By this time, a total of 621 machines of both versions had been produced, 325 of which were the bis version. The very first time the type saw combat action was during the Italian attack on Abyssinia (Ethiopia). They also fought in the Spanish Civil War, operated both by the Aviazione Legionaria and by the Aviación Nacional.

Following the outbreak of the Second World War, the type saw service everywhere the Regia Aeronautica were fighting, except for the Eastern Front and across the English Channel. By the time Italy became involved in the war, the Regia Aeronautica had had 483 of both versions, 200 of which were the bis, but only about a hundred of machines were in fact in air worthy conditions. They saw service over the Balkans, Northern Africa and mainland Italy too. Based on the Ro.37/Ro.37bis airframe, two seaplane versions were also developed, these being known as the IMAM Ro.43 single float seaplane which was capable of being catapult launched from warships and the IMAM Ro.44 single float fighter seaplane.

As the type possessed rather satisfactory performance and also because of the fact that two different powerplants were possible for the airframe to be fitted with, both the types were successfully offered to users abroad. In Europe, the type was flown with the Royal Hungarian Air Force as well as in Austria and in Spain by the Nationalists. The bis version was seen also outside Europe, flying with the military of Afghanistan, Paraguay and Ecuador.

Wingspan: 11.08 m, Length: 8.62 m, Top Speed: 325 km/h, Range: 1,650 km, Armament: 2× fixed 12.7 mm Breda – SAFAT machine gun, 1× 7.7 mm Lewis or Breda machine gun in rear cockpit, a dozen of 12 kg or 15 kg bombs.

# PLASTIC PARTS

**A**

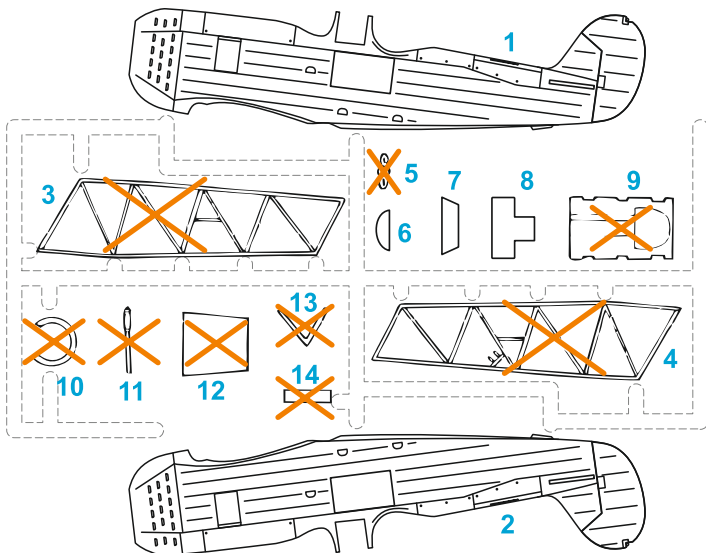

**E**

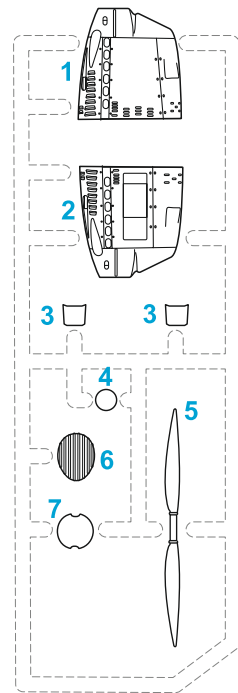

**B**

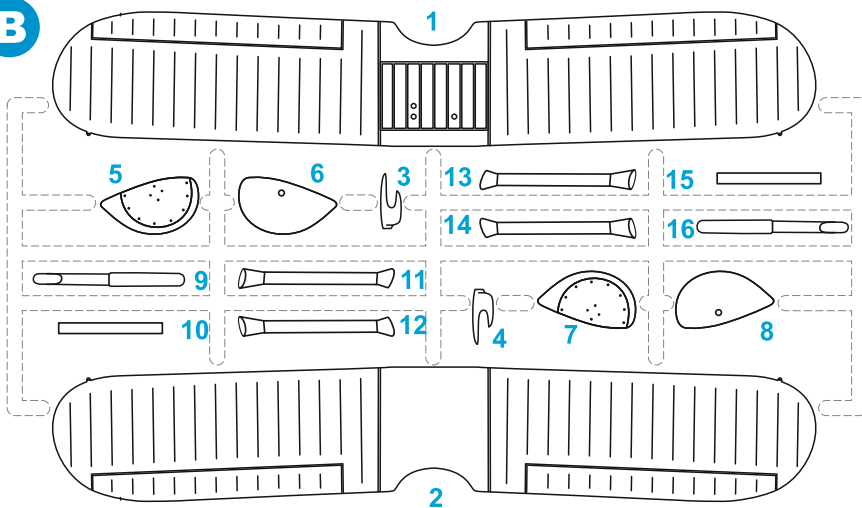

**F**

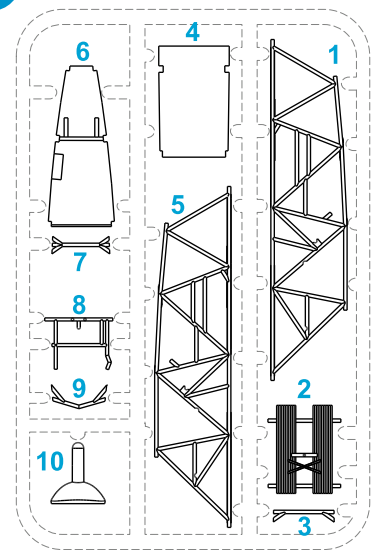

**C**

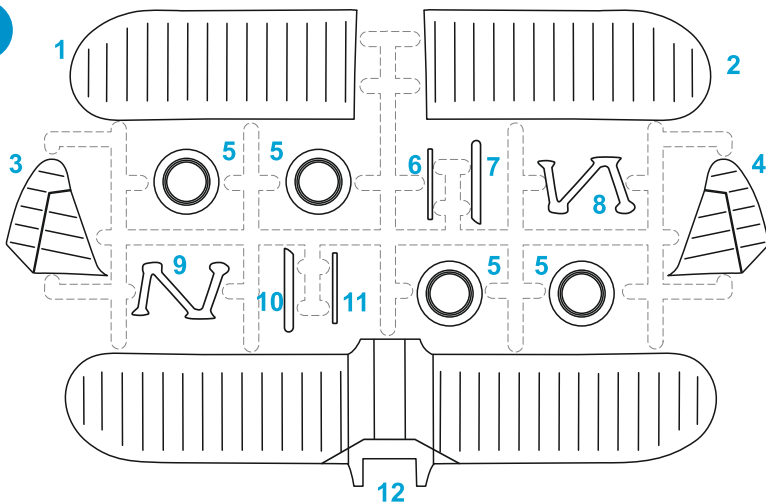

 *Tento díl nepoužít*  
*Do not use this part*

## SYMBOLS

 **MOŽNOST VOLBY**  
OPTIONAL  
NACH BELIEBEN  
OPTION

 **POUŽÍŤ KYANOAKRYLÁTOVÉ LEPIDLO**  
INSTANT CYANOACRYLATE GLUE  
ZYANOAKRYLÁTKLEBER  
COLLE CYANOACRYLAT

 **OHNOUT**  
BEND  
BIEGEN  
COURBER

 **ZHOTOVIT NOVÉ**  
SCRATCH BUILD  
FERTIGSTELLEN  
ACHEVER

 **ŘEZAT/VRTAT**  
CUT OFF/DRILL  
ENTFERNEN  
DETACHER

GSI  **colour code**

**NATRÍT**  
COLOUR  
FARBEN  
PEINDRE

## CLEAR PARTS (CP)

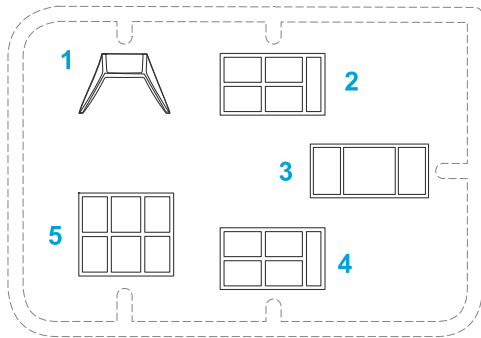

## PUR PARTS (PUR)

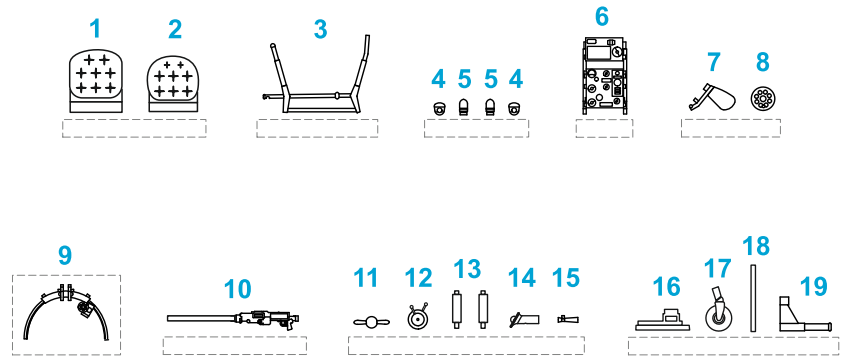

## PHOTO-ETCHED PARTS (PE)

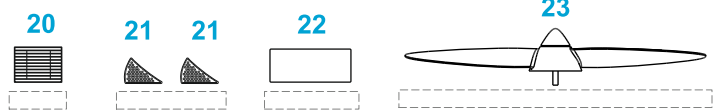
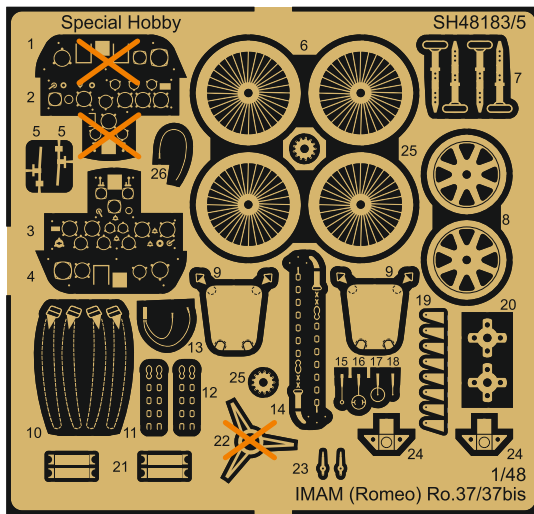

**X** Tento díl nepoužít  
Do not use this part

## FILM (F)

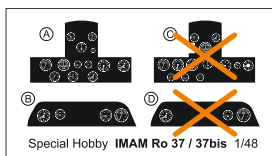

## MASK

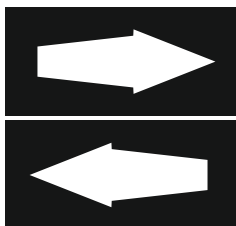

## Barvy GUNZE/ GUNZE Colour No.

A	Černá matná / Flat Black	H12 / C33
B	Černá / Black	H2 / C2
C	Světle šedomodrá / Light Blue-grey	H324 / C324
D	Hliníková / Aluminium	H8 / C8
E	Plátno / Linen (Tan)	H27 / C44
F	Černá kůže / Black Leather	H47 + H12 / C41 + C33
G	Bílá / White	H1 / C1
H	Opálený kov / Burn Iron	H76 / C61
I	Tmavý kov / Metal Black	H28 / C18
J	Barva pneu / Tire Black	H77 / C137
K	Červená čirá / Clear Red	H90 / C47
L	Zelená čirá / Clear Green	H94 / C138

## SYMBOLS



MOŽNOST VOLBY  
OPTIONAL  
NACH BELIEBEN  
OPTION



POUŽÍT KYANOAKRYLÁTOVÉ LEPIDLO  
INSTANT CYANOACRYLATE GLUE  
ZYANOAKRYLÁTKLEBER  
COLLE CYANOACRYLAT



OHNOUT  
BEND  
BIEGEN  
COURBER



ZHOTOVIT NOVÉ  
SCRATCH BUILD  
FERTIGSTELLEN  
ACHEVER



ŘEZAT/VRTAT  
CUT OFF/DRILL  
ENTFERNEN  
DETACHER



GSI  
colour code

NATRÍT  
COLOUR  
FARBEN  
PEINDRE

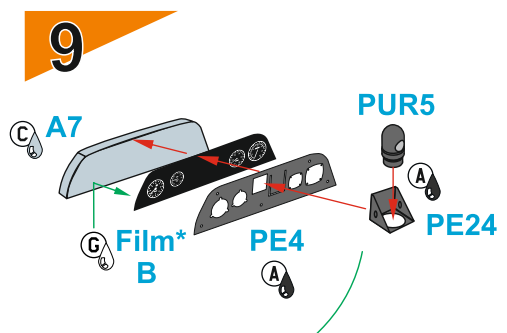
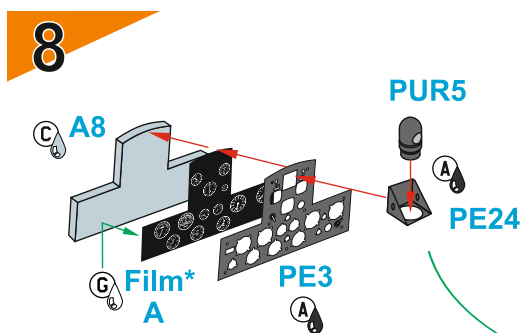
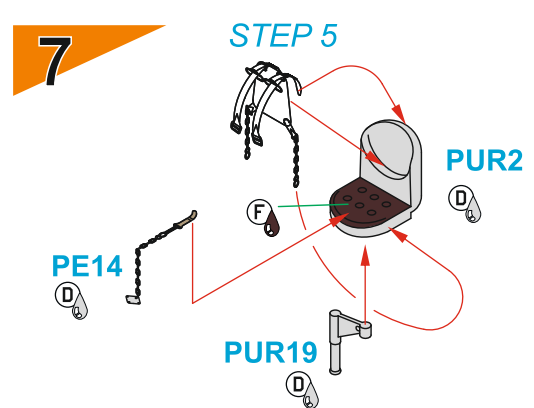
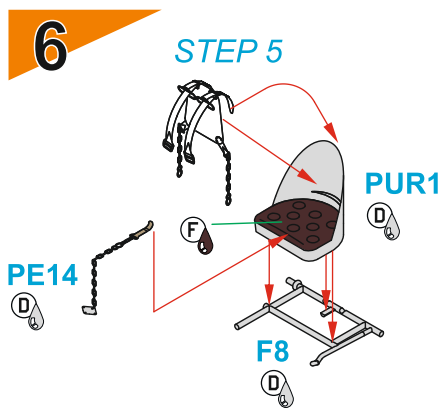
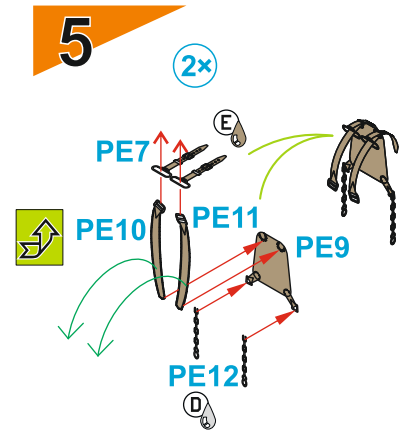
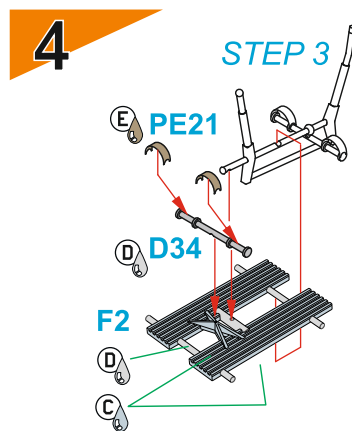
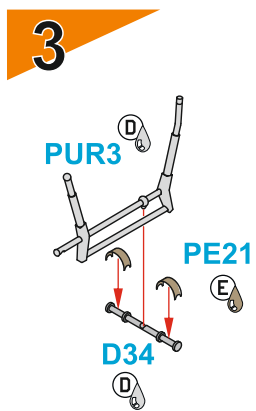
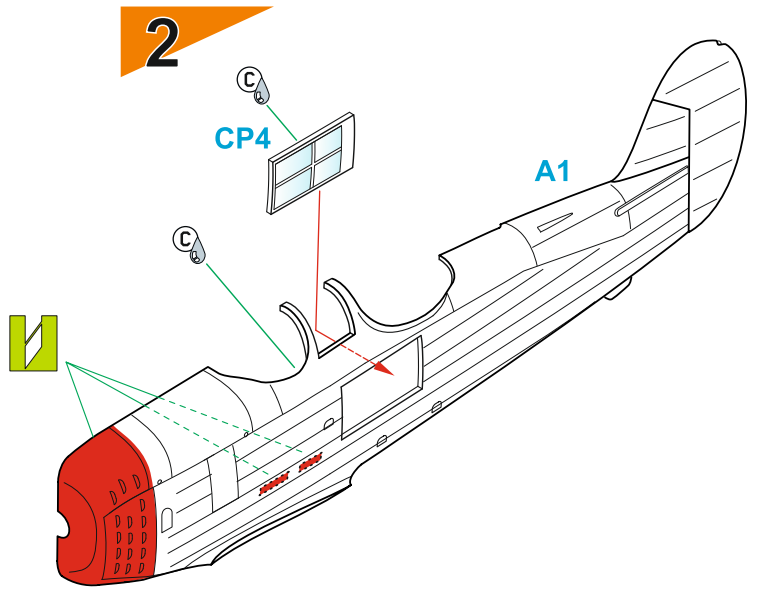
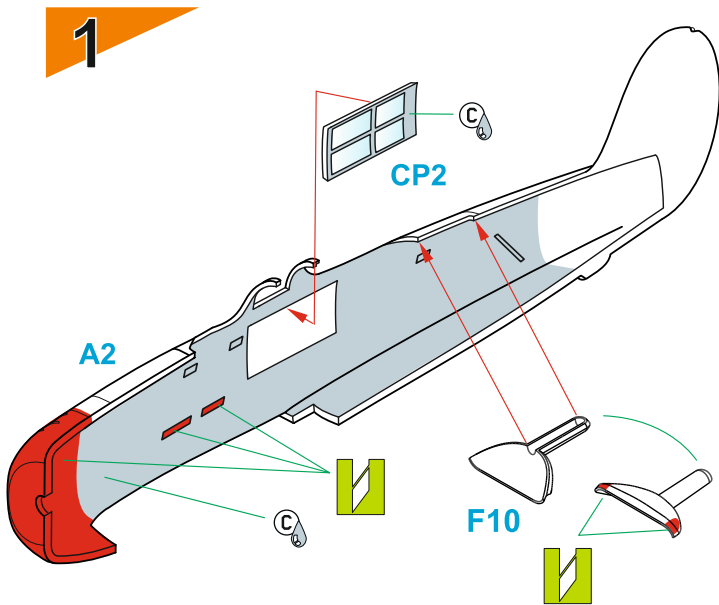

\* Nabarvěte zadní stranu fólie bílou barvou před kompletací.  
Paint the back of film parts White before assembly.

10

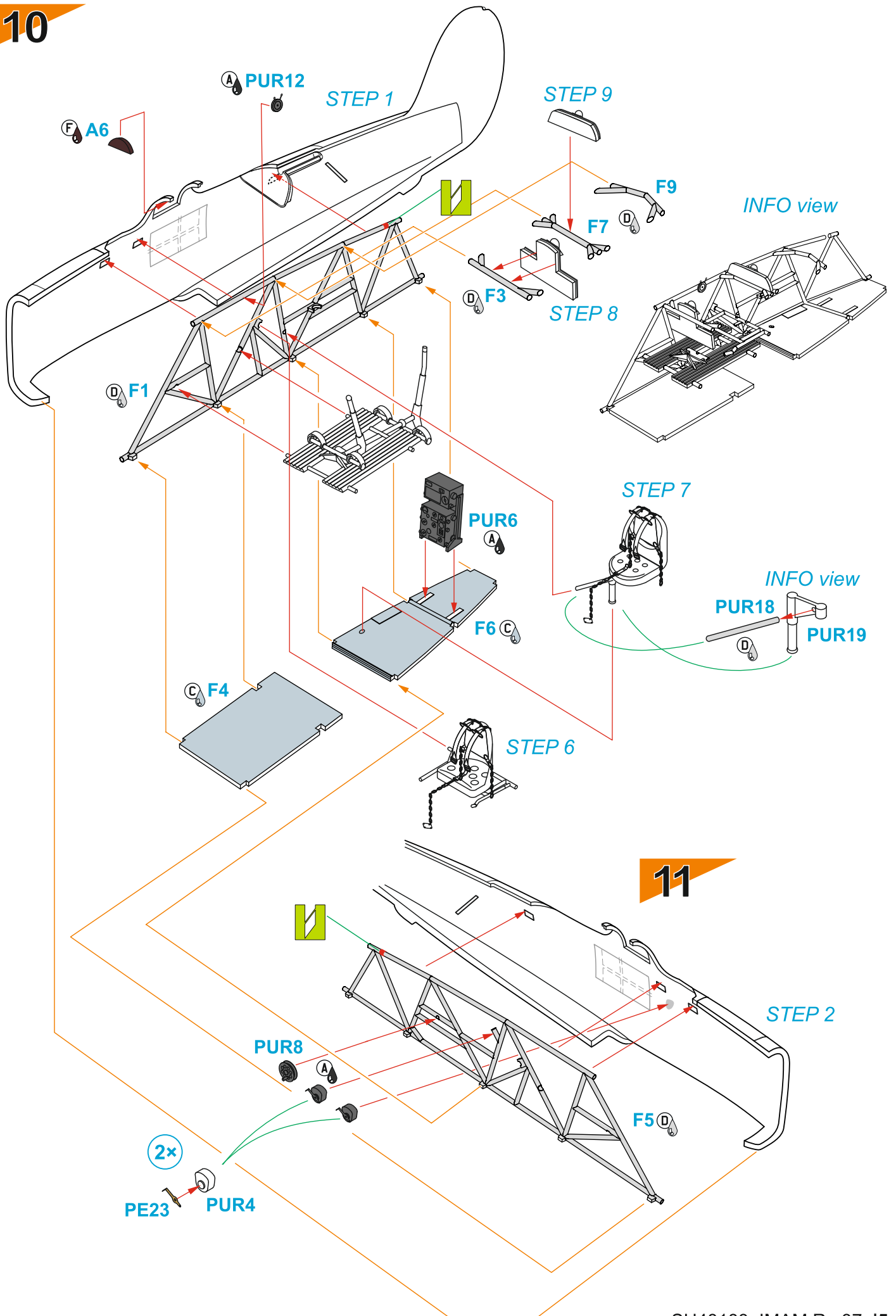

11

**STEP 2**

# 12

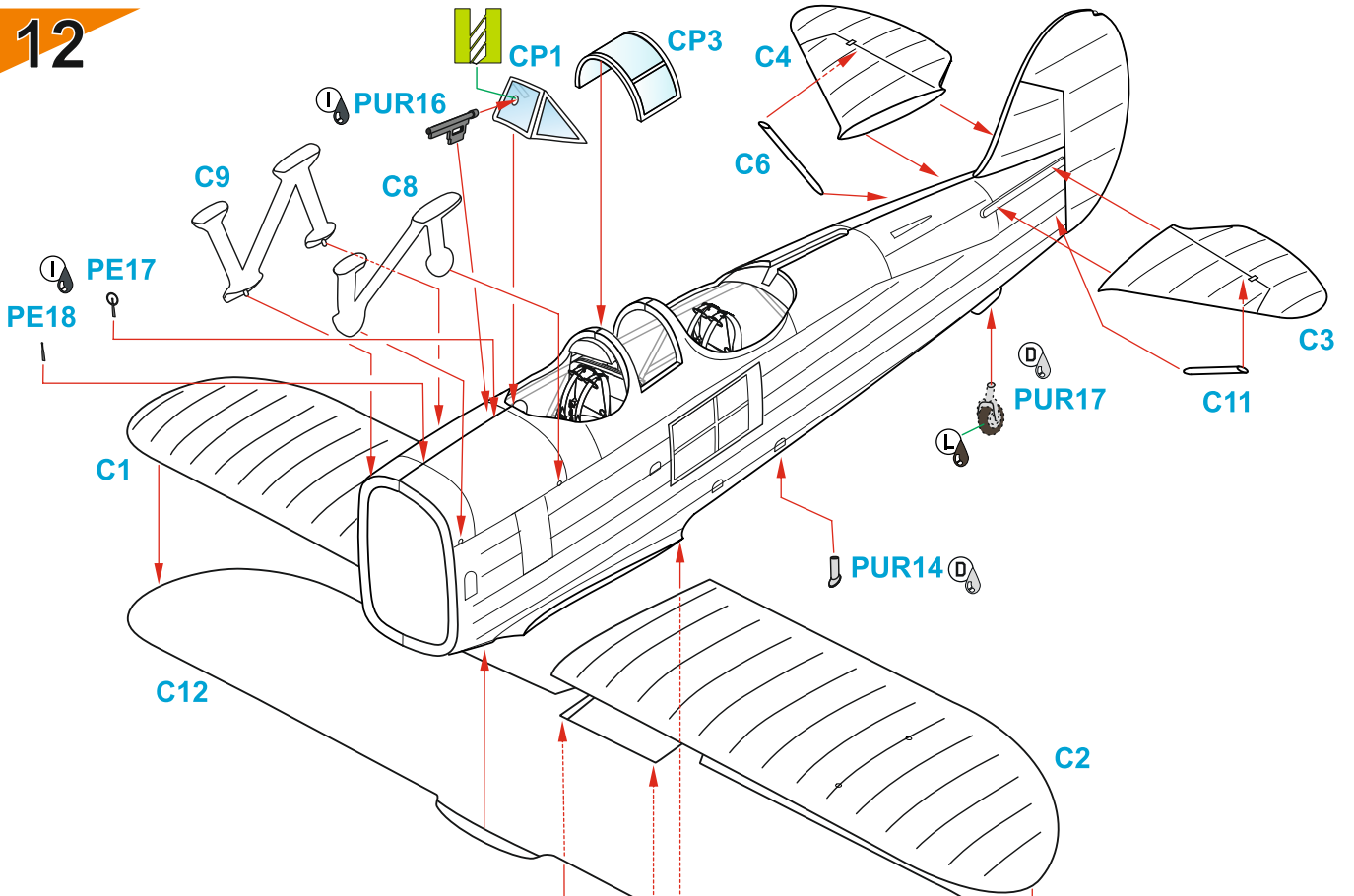

# 13

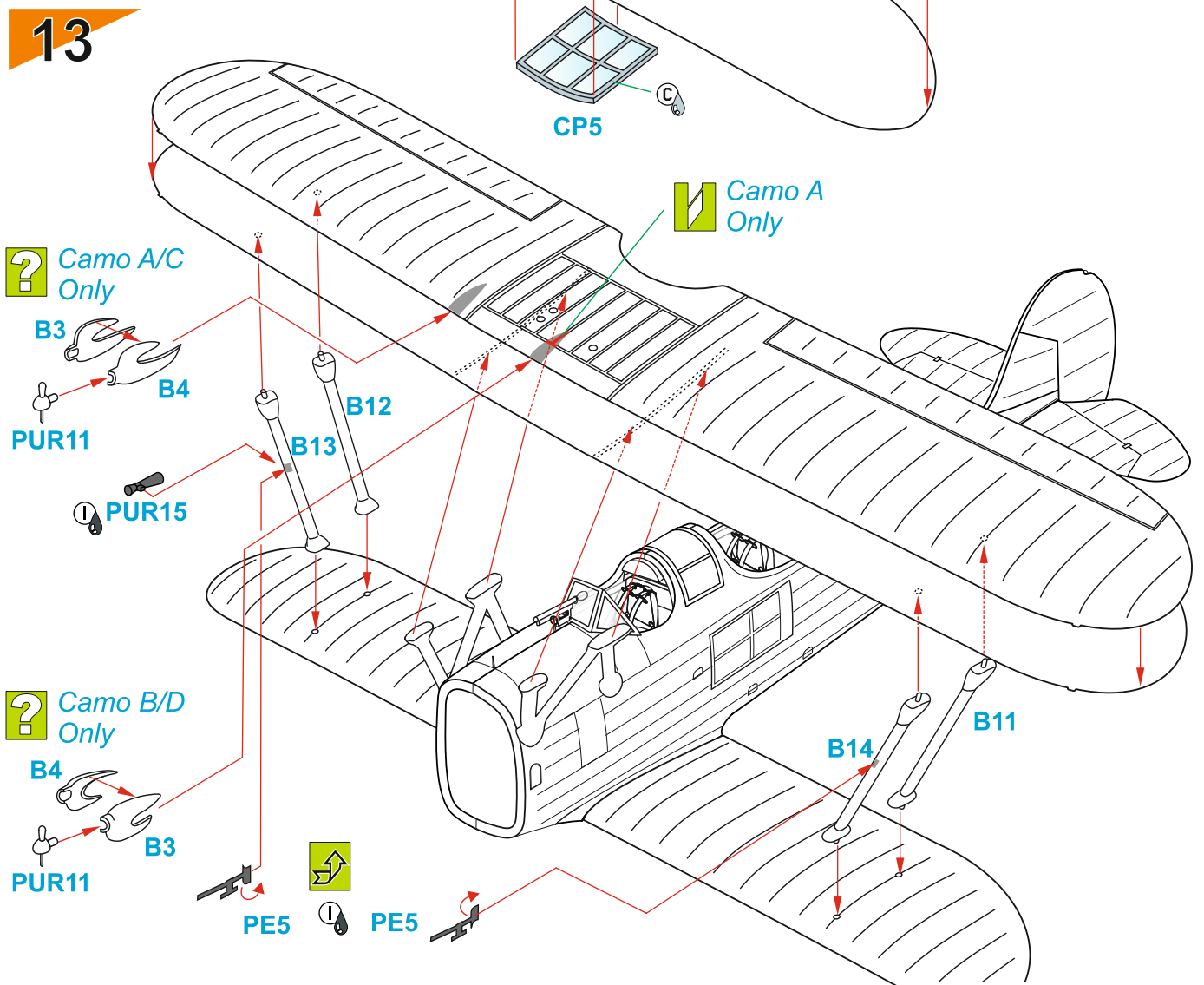

# 14

**?**  
Camo D  
Only

PUR23

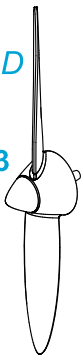

**?**  
Camo A/B/C  
Only

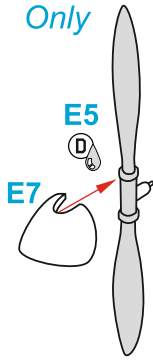

**?**  
Camo D  
Only

PUR21

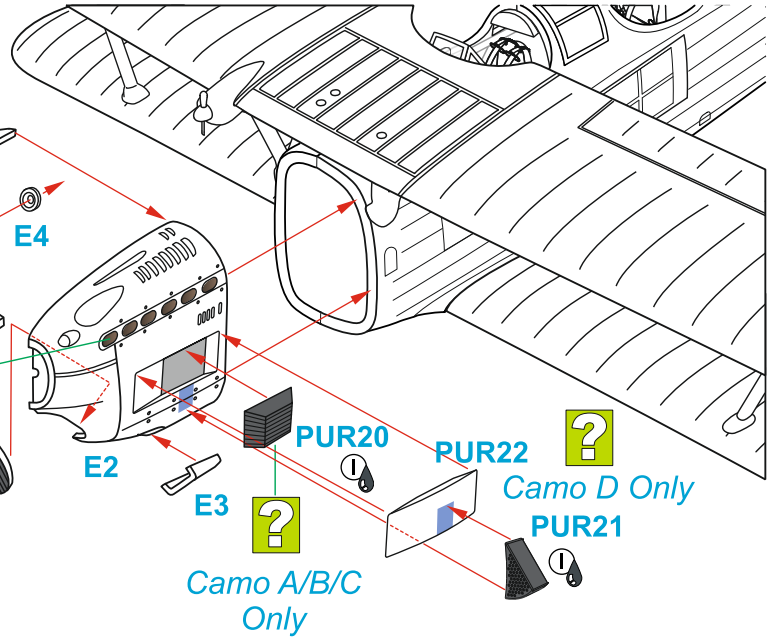
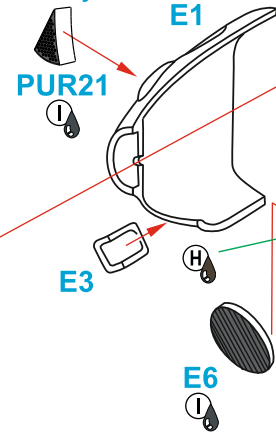

# 15

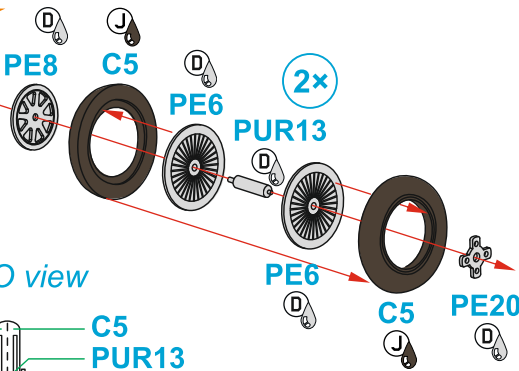

INFO view

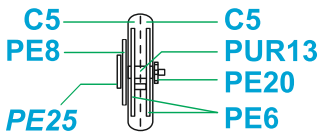

Camo C/D  
Only

# 16a

**?**  
Camo A/B  
Only

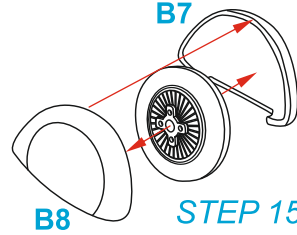

# 16b

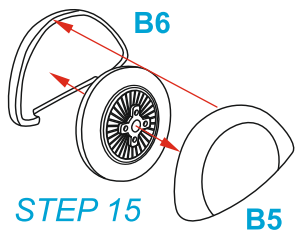

# 17

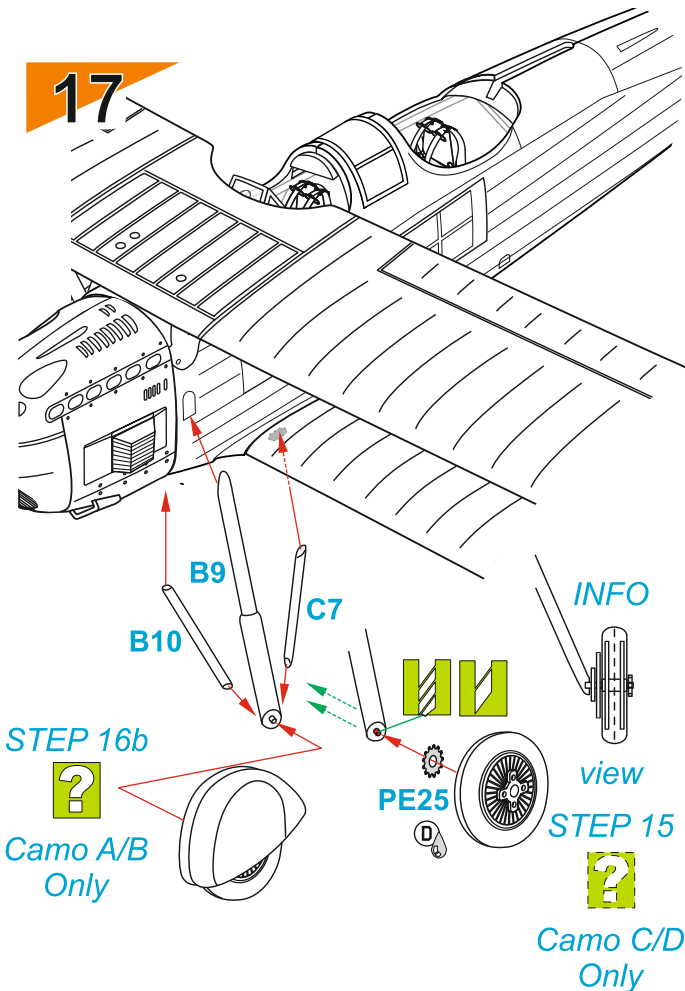

# 18

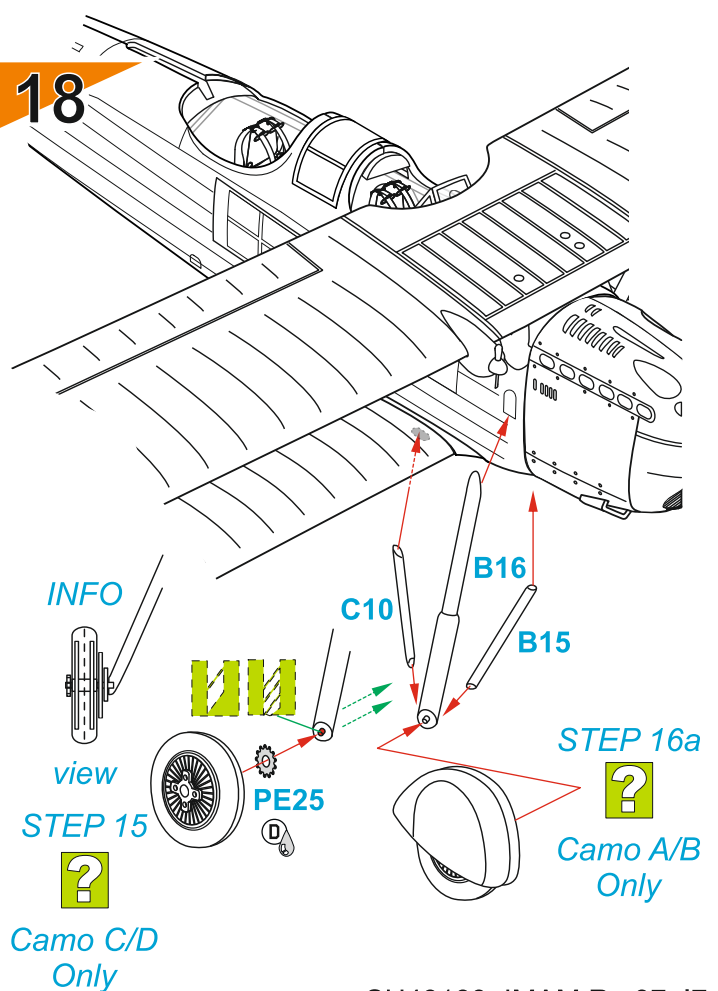

19

? Camo A/B/C Only

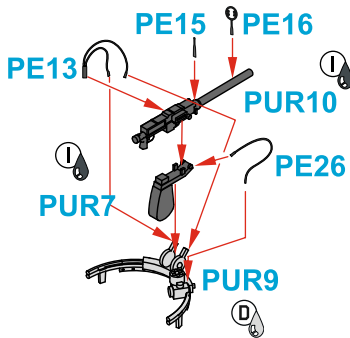

? Camo A/B/C Only

STEP 19

? Camo D Only

20

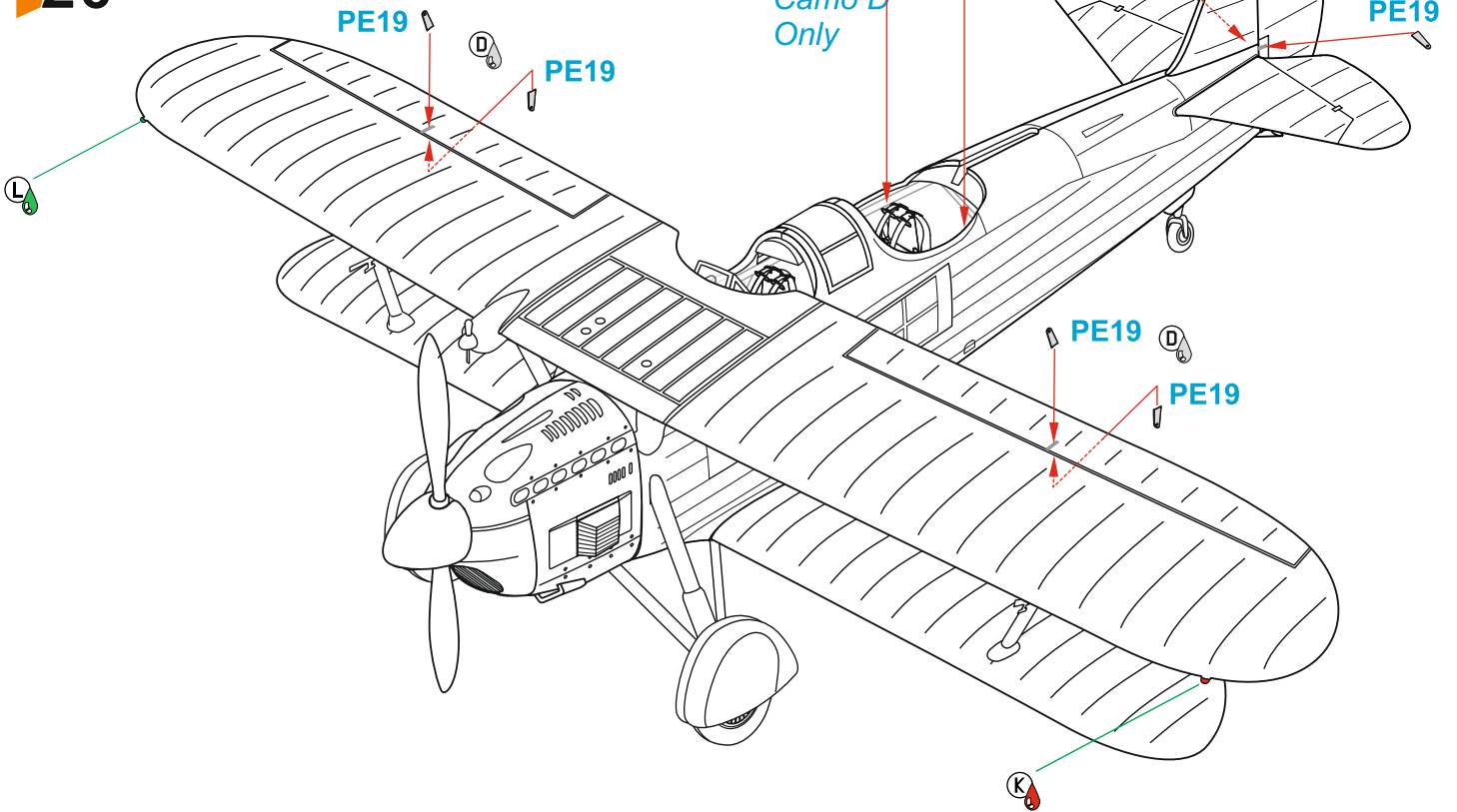

21

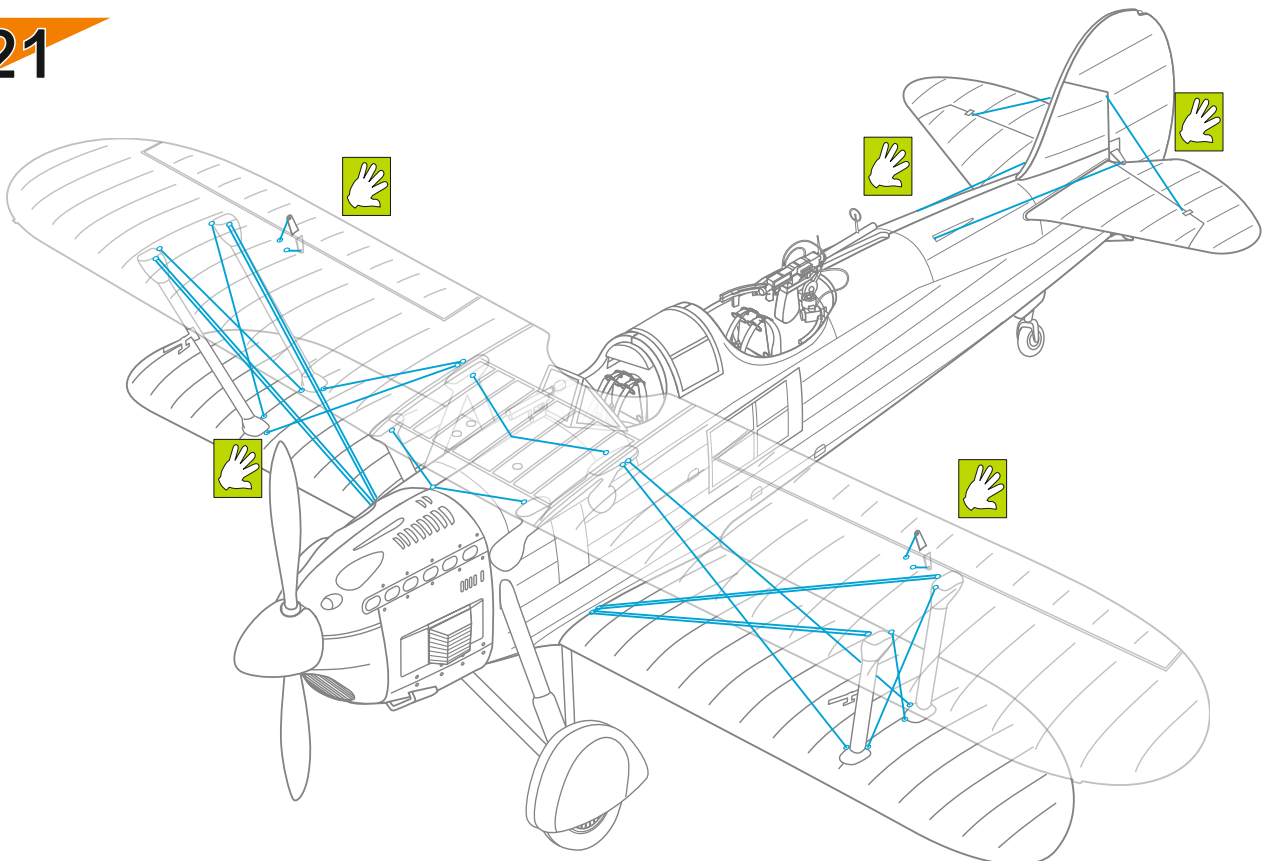



**IMAM (Romeo) Ro.37, 115-3, M.M. 11115, 115a**  
 Squadriglia, 67° Gruppo O.A., Regia Aeronautica,  
 Bologna-Borgo Panigale, listopad 1938. Letoun byl  
 vyroben v rámci II serie továrnou Caproni Taliedo.

**IMAM (Romeo) Ro.37, 115-3, M.M. 11115, 115a**  
 Squadriglia, 67° Gruppo O.A., Regia Aeronautica,  
 Bologna-Borgo Panigale, November 1938. A second  
 series machine produced et Caproni Taliedo plant.

**CAM. A**

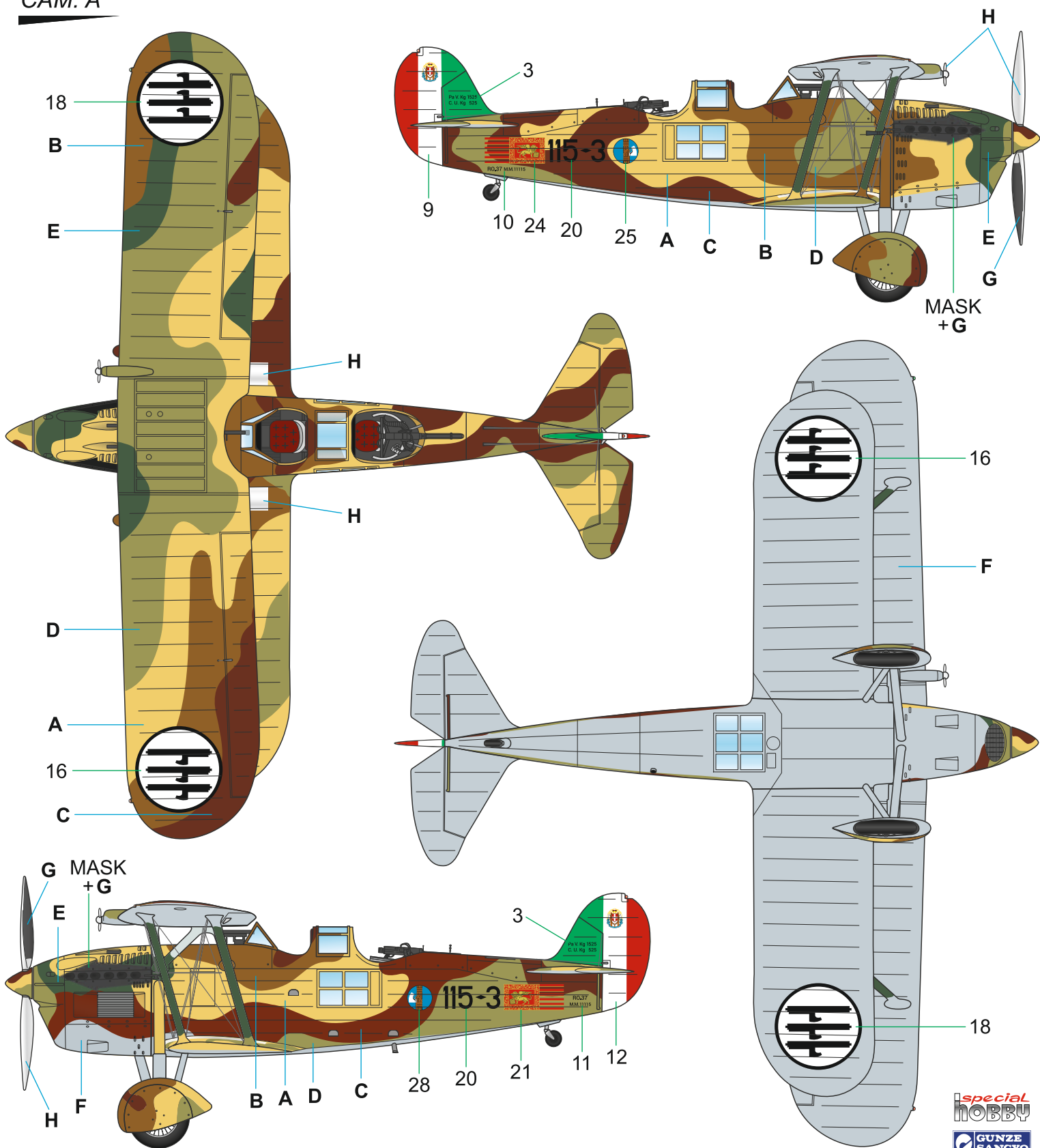

- |  |   |   |  |  |
|--|---|---|--|--|
| <b>A</b> Žlutá / Yellow<br>Giallo Mimetico 1<br>H313/C313      | <b>B</b> Hnědá / Brown<br>Marrone Mimetico 1<br>H37/C43 | <b>C</b> Hnědá / Brown<br>Marrone Mimetico 2<br>H47/C41 | <b>D</b> Zelená / Green<br>Verde Mimetico 1<br>H422/C122 | <b>E</b> Zelená / Green<br>Verde Mimetico 3<br>H303/C303 |
| <b>F</b> Šedomodrá / Blue-grey<br>Grigio Mimetico<br>H317/C317 | <b>G</b> Černá / Black<br>H12/C33                       | <b>H</b> Stříbrná / Silver<br>H8/C8                     |  |  |



**CAM. B**

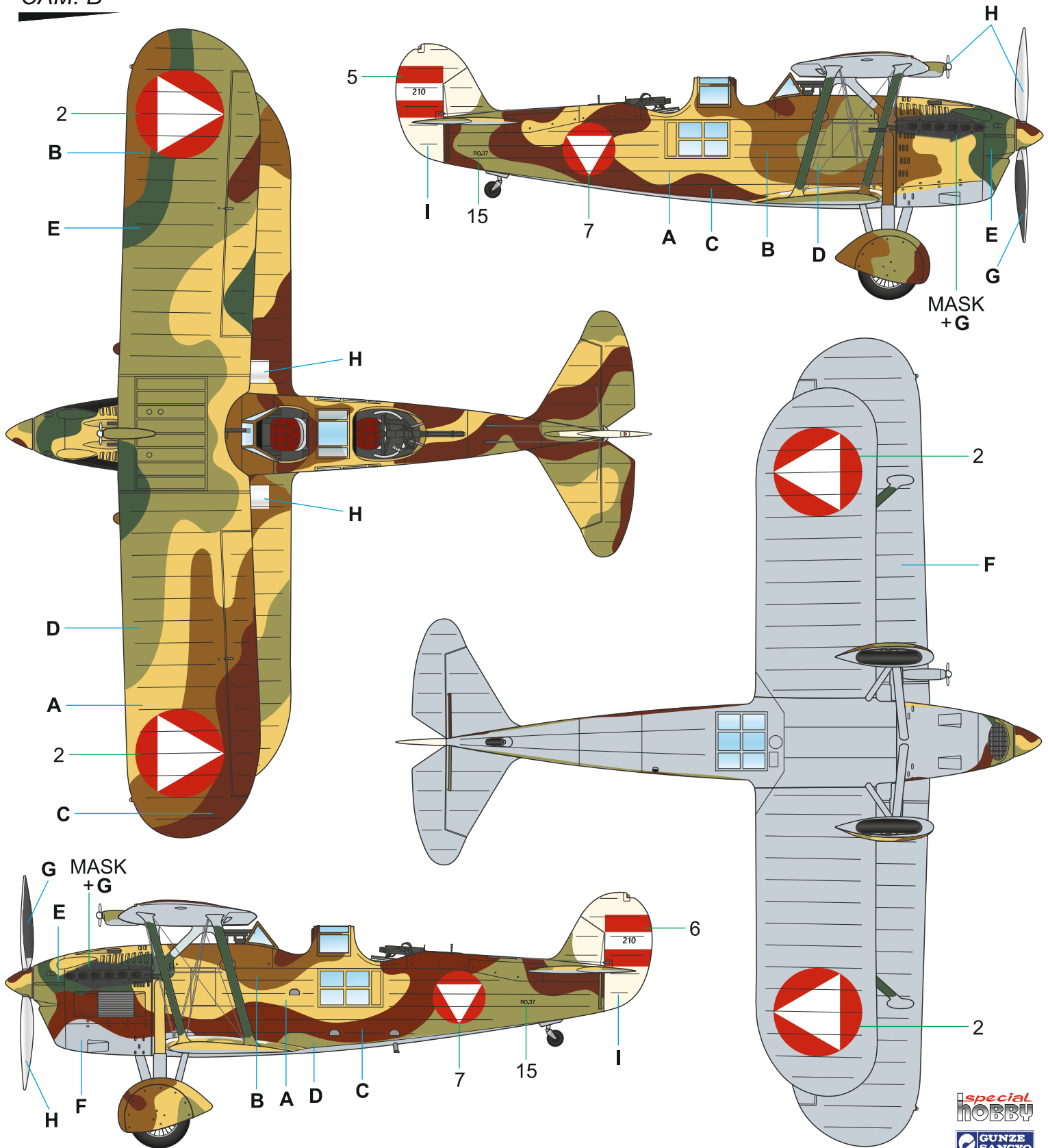

- |  |   |   |  |  |
|--|---|---|--|--|
| <b>A</b> Žlutá / Yellow<br>Giallo Mimetico 1<br>H313 / C313      | <b>B</b> Hnědá / Brown<br>Marrone Mimetico 1<br>H37 / C43 | <b>C</b> Hnědá / Brown<br>Marrone Mimetico 2<br>H47 / C41 | <b>D</b> Zelená / Green<br>Verde Mimetico 1<br>H422 / C122 | <b>E</b> Zelená / Green<br>Verde Mimetico 3<br>H303 / C303 |
| <b>F</b> Šedomodrá / Blue-grey<br>Grigio Mimetico<br>H317 / C317 | <b>G</b> Černá / Black<br>H12 / C33                       | <b>H</b> Stříbrná / Silver<br>H8 / C8                     | <b>I</b> Špinavě bílá / OffWhite<br>H21 / C69              |  |

**IMAM (Romeo) Ro.37, 31-4, M.M. 10954, 31a**  
 Squadriglia, 5° Gruppo O.A., Regia Aeronautica,  
 letiště Bari, 1940.

**IMAM (Romeo) Ro.37, 31-4, M.M. 10954, 31a**  
 Squadriglia, 5° Gruppo O.A., Regia Aeronautica, Bari,  
 1940.

**CAM. C**

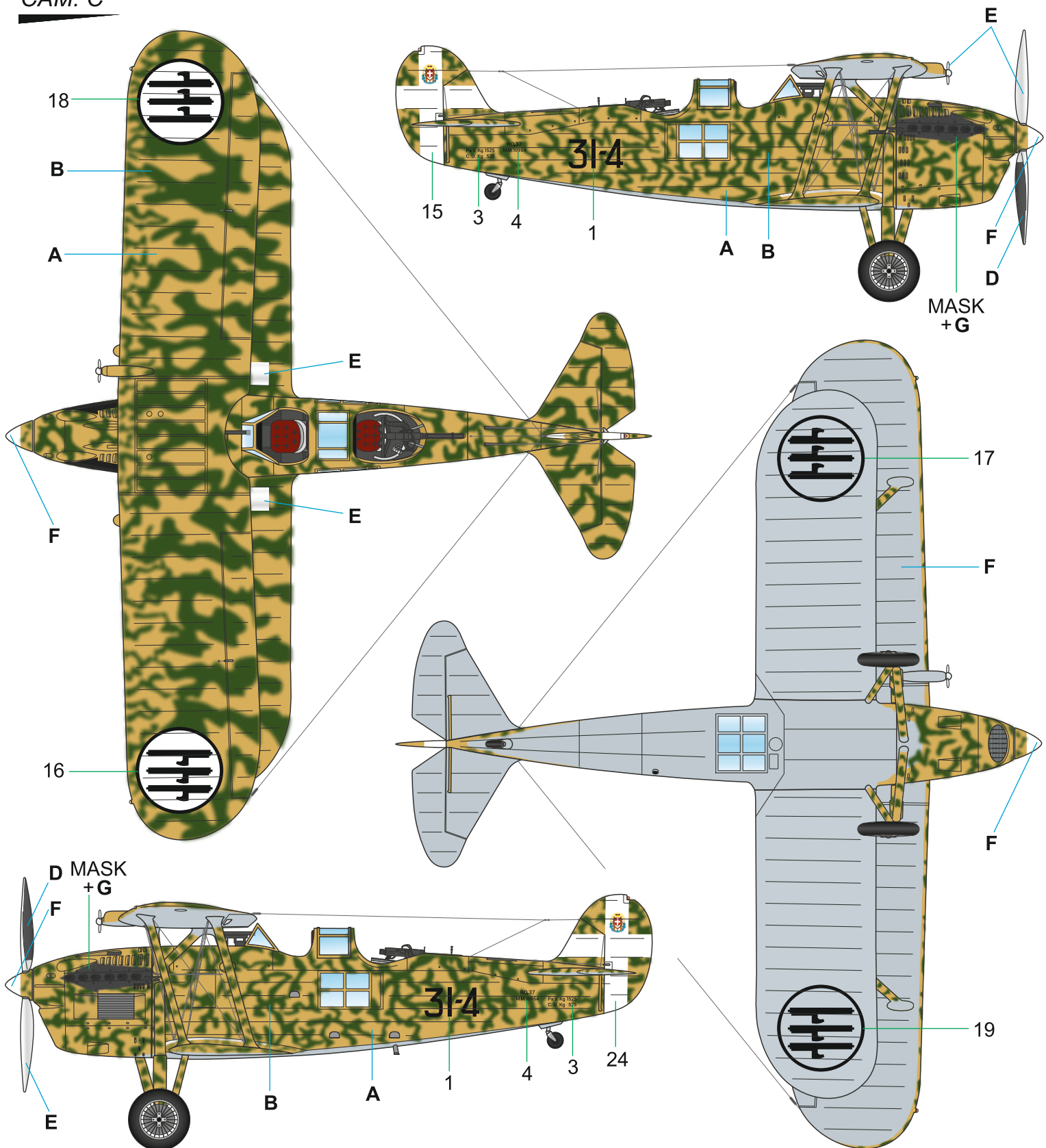

**A** Žlutá / Yellow  
 Giallo Mimetico 1  
 H313 / C313

**B** Zelená / Green  
 Verde Mimetico 3  
 H303 / C303

**C** Šedomodrá / Blue-grey  
 Grigio Mimetico  
 H317 / C317

**D** Černá / Black  
 H12 / C33

**E** Stříbrná / Silver  
 H8 / C8

**F** Bílá / White  
 H1 / C1



**IMAM (Romeo) Ro.37**, černá 6, M.M. 10566, 103a Squadriglia, Regia Aeronautica, letiště Mek'ele, okupované území Etiopského císařství (Habeše), 1935.

**IMAM (Romeo) Ro.37**, black 6, M.M. 10566, 103a Squadriglia, Regia Aeronautica, Mek'ele, occupied territory of the Ethiopian empire (Abyssinia), 1935.

**CAM. D**

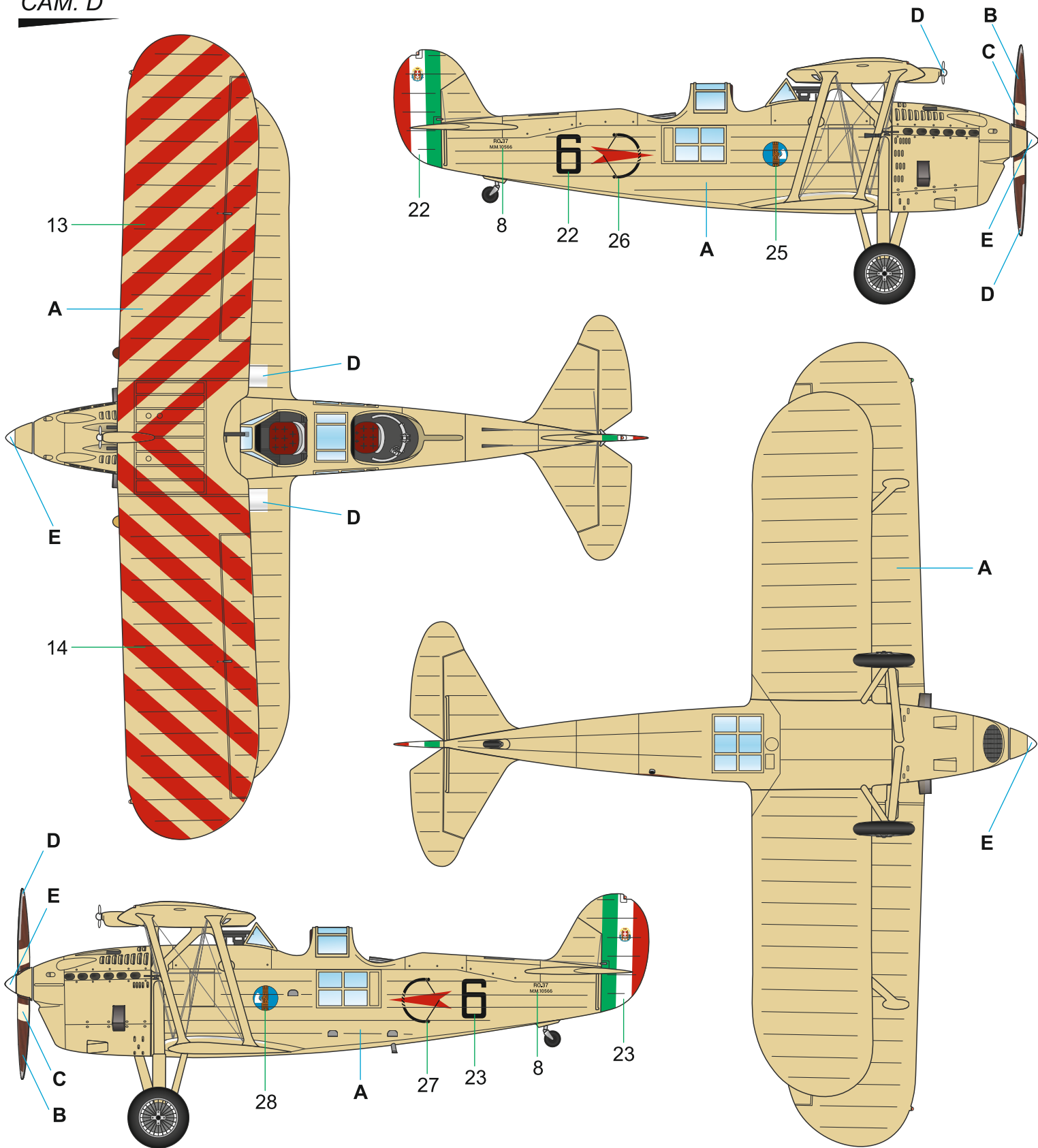

**A** Krémová / Radome H318 / C318    **B** Dřevo / Wood Brown H37 / C43    **C** Plátno / Linen H85 / C45

**D** Stříbrná / Silver H8 / C8    **E** Bílá / White H1 / C1

