

Beaufighter Mk.II, EW-A/R2445, No.307 (Polish) Squadron RAF, Clyst Honiton, Winter 1941-42. On 14 February 1942 the machine struck the ground during a training flight killing its pilot P/O Stefan Maksymowicz-Raczyński and leaving operator F/O Jerzy Łazarowicz seriously injured.

Beaufighter Mk.II, EW-A/R2445, No.307 (Polish) Squadron RAF, Clyst Honiton, zima 1941/42. Při cvičném letu 14.2. 1942 letoun havaroval, pilot P/O Stefan Maksymowicz-Raczyński zahynul, operátor F/O Jerzy Łazarowicz byl těžce zraněn.

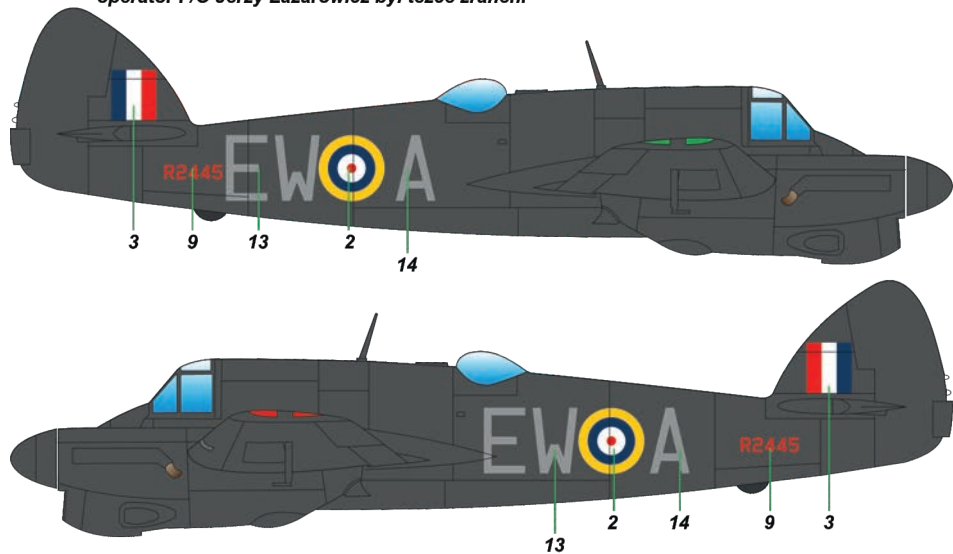

Special Hobby also offers the following conversion sets in the CMK series:

7465
1/72
Hurricane PR Mk.I/II
Conversion Set
for Arma Hobby kits
PUR - Polyurethane parts

7446
1/72
DAP Beaufighter Mk.21
Conversion Set
for Arma kit
D - decal sheet part1 + part 2
CP - Clear parts

7448
B-25G Mitchell
Conversion Set
Contains detail resin parts (nose and new cockpit) -etched parts and two decal options. For B-25C/

Decal Options
2x USAAF



Odlévaný set / All resin set

7489
1/72

Beaufighter Mk.II Early Type Conversion Set

for Airfix Beaufighter Mk.X kit

www.cmkkits.com
www.specialhobby.eu

Visit our official website and e-shop at
PUR - Polyurethane parts

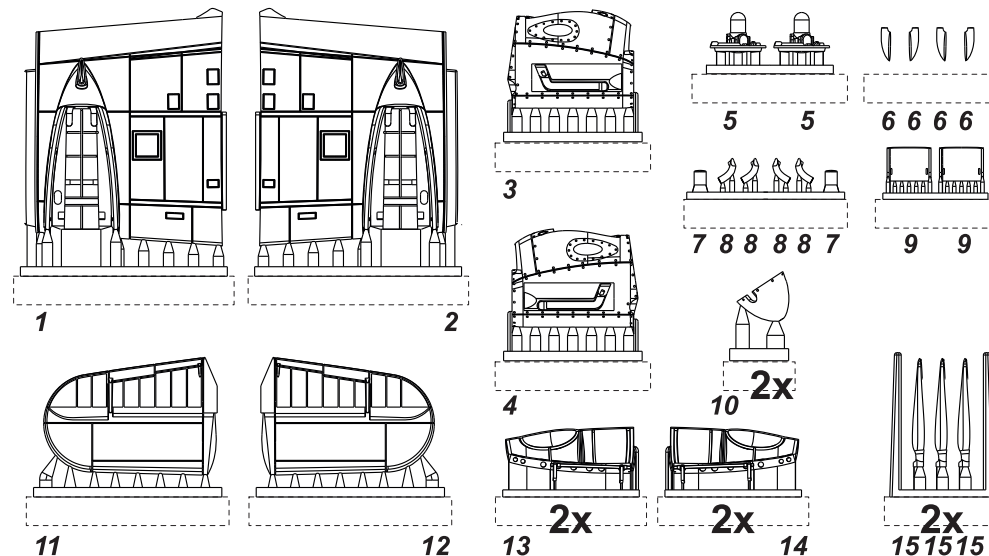

Decal Sheet

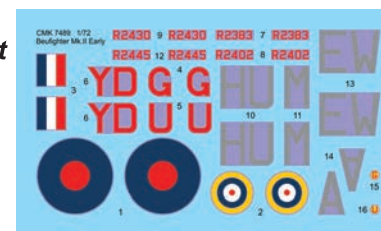

PE Parts



Díly ohnuté popř. pokroucené vlivem teplotních změn a stárnutí materiálu, mohou být narovnány do požadovaného tvaru pomocí proudu teplé vody nebo vzduchu (fén na vlasy). Různé drátky a tyčky nejsou přiloženy. Kontaktní plochy doporučujeme před lepením odmastit.

Parts slightly distorted and bent owing to temperature changes or due to material ageing can be straightened to requested shape by hot water or hot air jet (hair dryer). This process can be repeated till result is entirely satisfactory. Wires and rods not included. It is recommended to remove grease from contact areas

K lepení použít kyanoakrylátové lepidlo / For best gluing results use cyanoacrylate glue!

SYMBOLS					
	MOŽNOST VOLBY OPTIONAL NACH BELIEBEN OPTION		POUŽÍŤ KYANOAKRYLÁTOVÉ LEPIDLO INSTANT CYANOACRYLATE GLUE ZYANOAKRYLATKLEBER ADHESIF CYANOACRYLAT		OHNOUT BEND BIEGEN COURBER
	ZHOTOVIT NOVĚ SCRATCH BUILD FERTIGSTELLEN ACHEVER		ŘEZATÍ/VRTAT CUT OFF/DRIILL ENTFERNEN DETACHER		NATŘÍT COLOUR FARBEN PEINDRE

Producer: Special Hobby, Mezilesí 718, 193 00 Praha 9, Czech Republic

Note/Pozn.

This instruction sheet only shows the build steps related to the conversion itself. While assembling the kit styrene parts, refer to the original Airfix Beaufighter Mk.X instruction booklet. (the 2015 release or its later reboxings).
Stavební návod ukazuje jen kroky použití konverzních dílů. Při lepení plastových dílů postupujte dle návodu stavebnice Beaufighter Mk.X (stavebnice Airfix vydaná v roce 2015 a její pozdější přebaly).

STEP 1

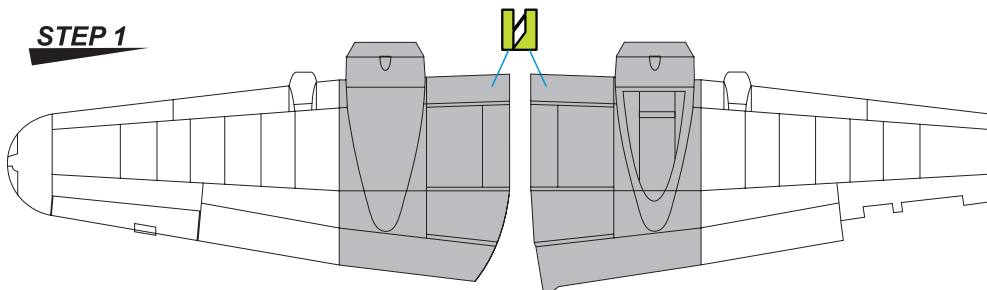

Cut off the shown wing sections with engine nacelles.
Odřízněte části křídla s motorovými gondolami.

STEP 2

2x

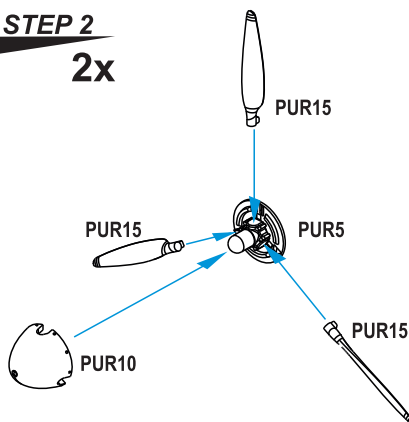

STEP 3

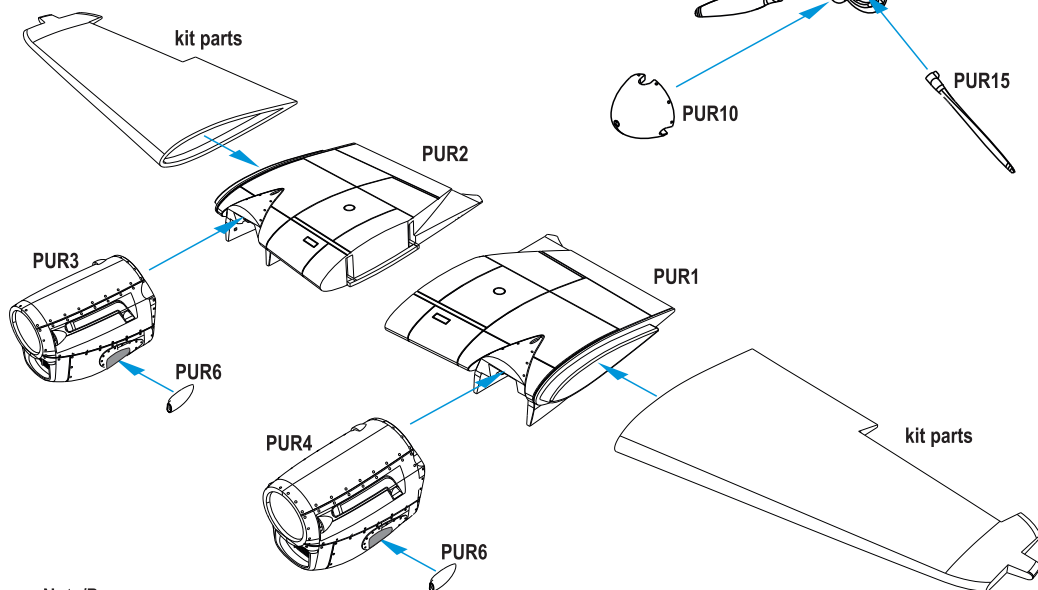

Note/Pozn.

Air intakes PUR6 to be attached on either side of both nacelles
Nasavače PUR6 nalepte z obou stran motorových gondol

Beaufighter Mk.II, YD-U/R2430, No.255 Squadron RAF, Coltishall, September 1941. This aircraft was flown by the crew of F/Sgt. E. Prchal and Sgt. R. Husár. On 7 September 1941 following a training flight, they landed with the port side engine engulfed in flames.

Beaufighter Mk.II, YD-U/R2430, No.255 Squadron RAF, Coltishall, září 1941. Na tomto stroji létala osádka F/Sgt. E. Prchal a Sgt. R. Husár. Po cvičném letu 7.září 1941 přistáli s tímto letounem s levým motorem v plamenech

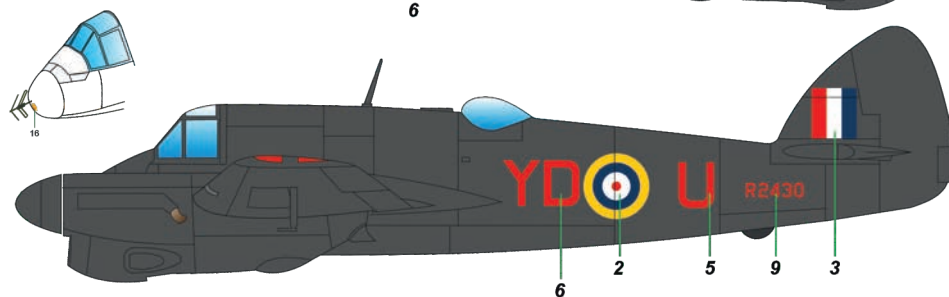
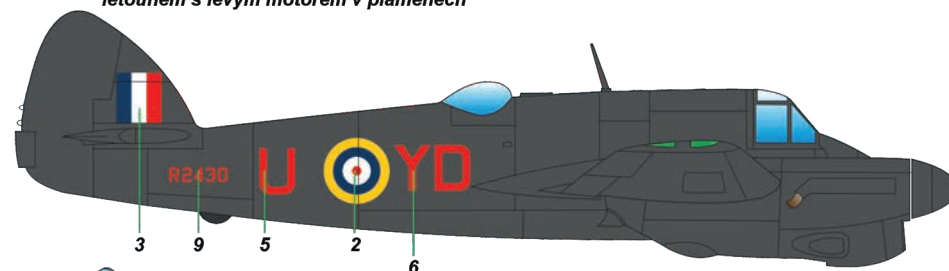

Beaufighter Mk.II, HU-M/R2383, No.406 (RCAF) Squadron, RAF Ayr, Scotland, February 1942. The engine nacelles were later adapted to the late style with individual exhaust stubs.
Beaufighter Mk.II, HU-M/R2383, No.406 (RCAF) Squadron RAF, základna Ayr, Skotsko, únor 1942. Motorové gondoly tohoto stroje byly později upraveny na pozdější standard s individuálními výfuky.

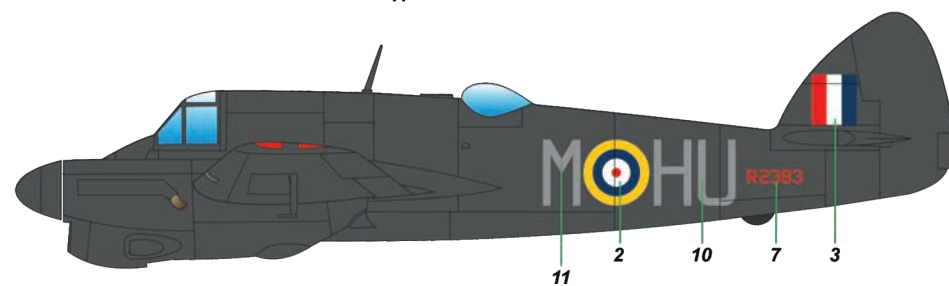
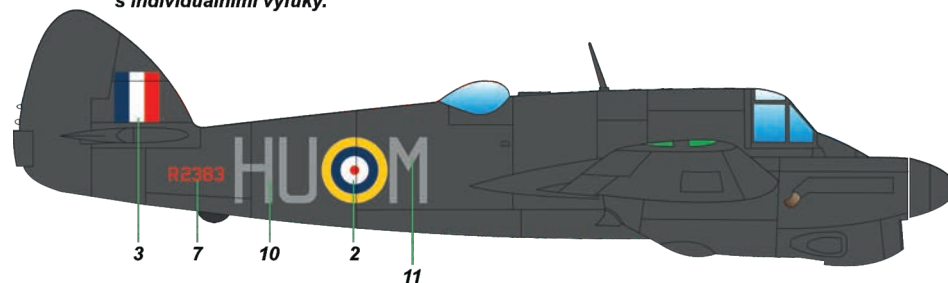

**Beaufighter Mk.II
camouflage schemes
kamuflažní schémata**

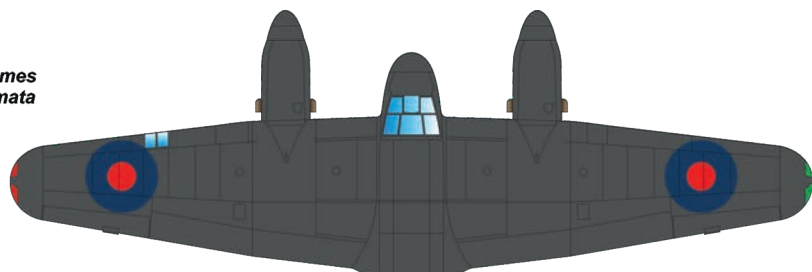

**Special Night RDM 2A
black colour (matt)**

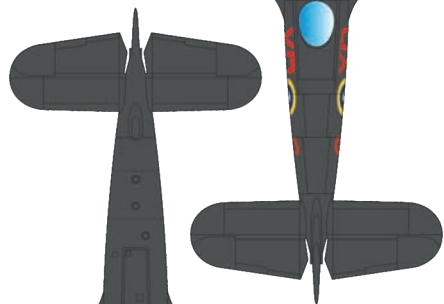

**Special Night RDM 2A
černý nátěr (matný)**

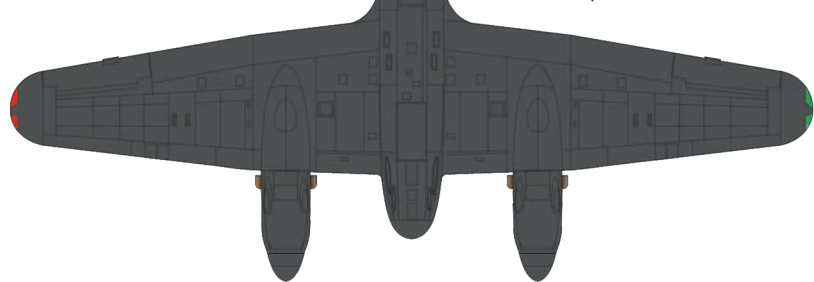

Beaufighter Mk.II, YD-G/R2402, No.255 Squadron RAF, Coltishall, November 1942.

Beaufighter Mk.II, YD-G/R2402, No.255 Squadron RAF, Coltishall, listopad 1942.

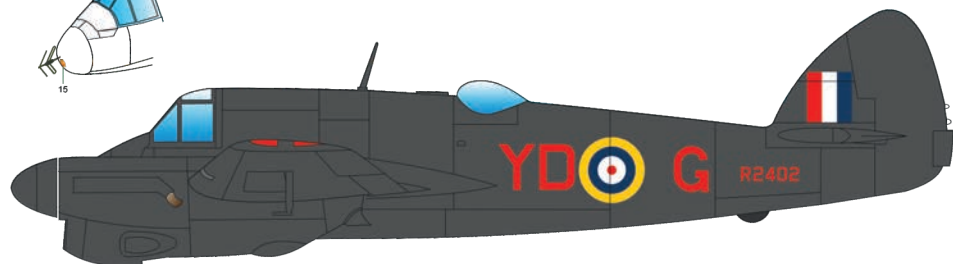
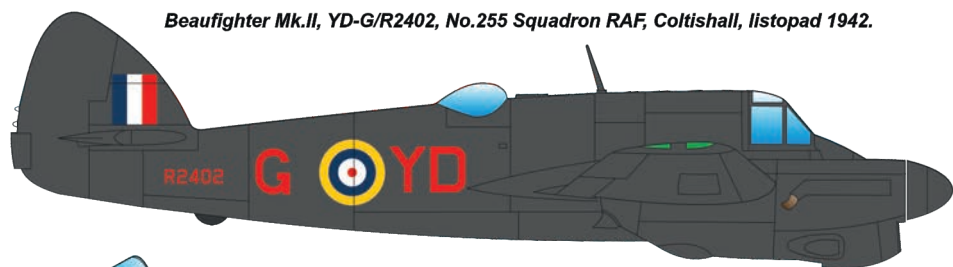

STEP 4

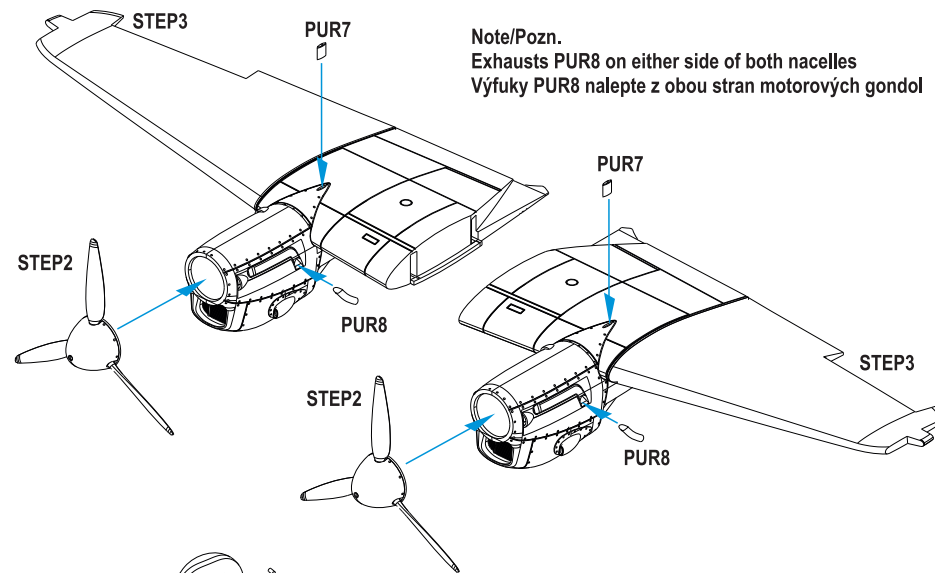

STEP 5

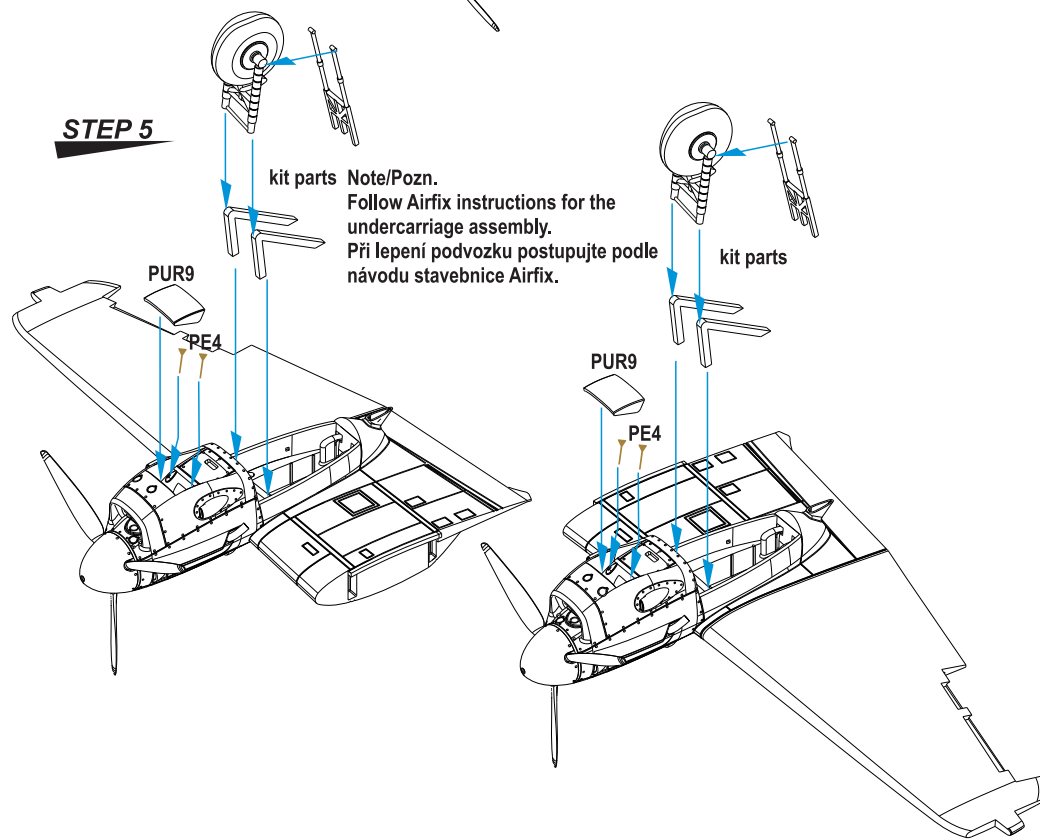

STEP 6

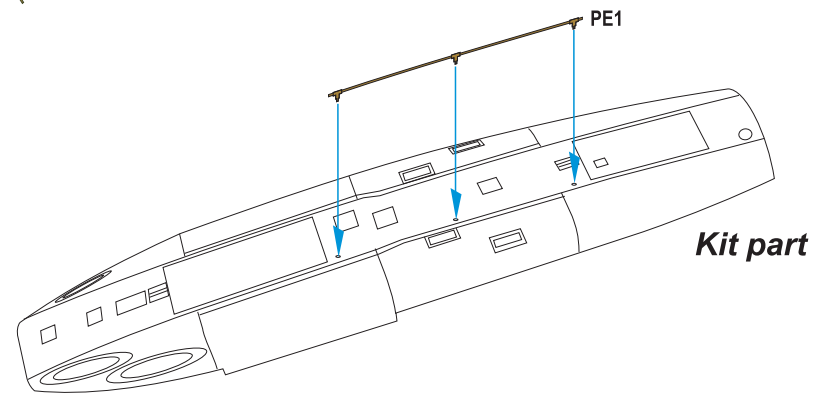
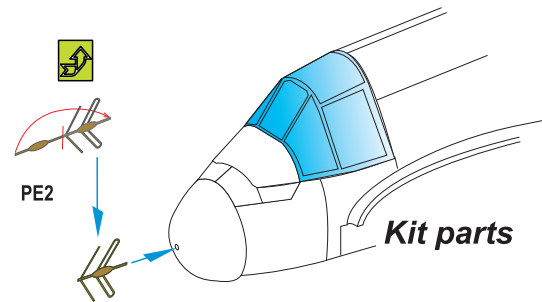
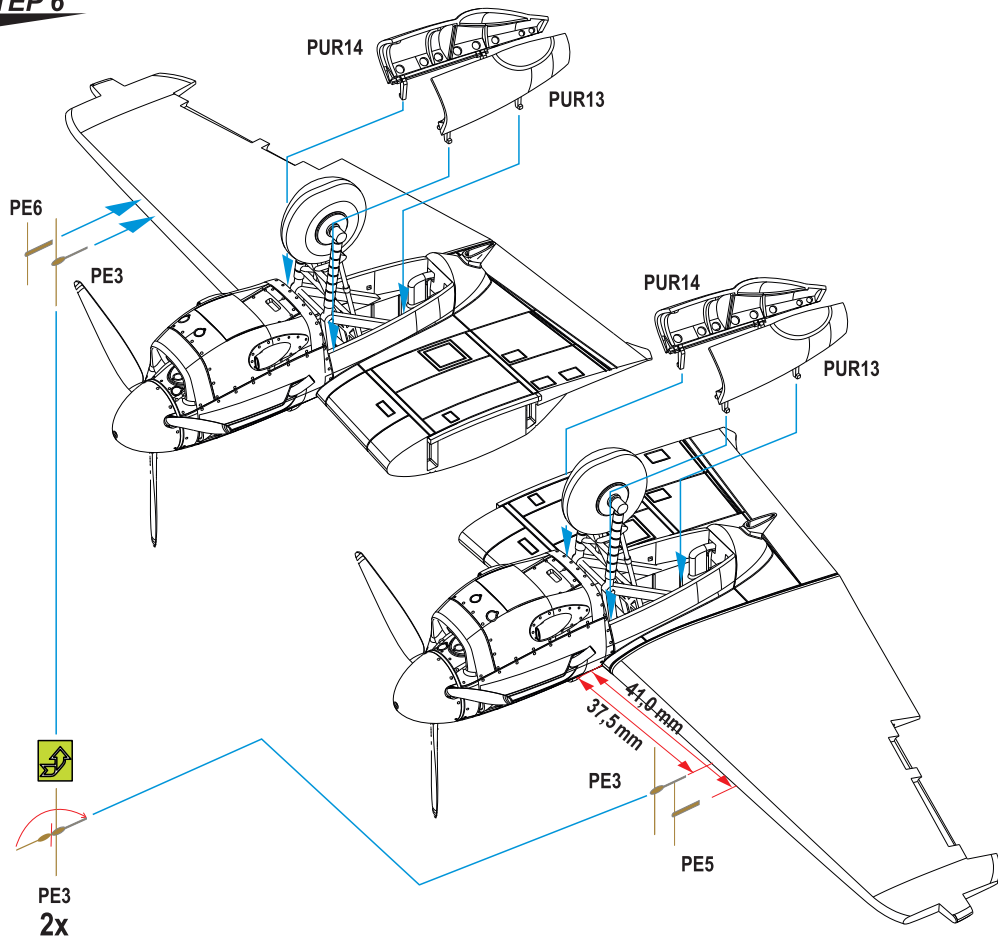

STEP 7

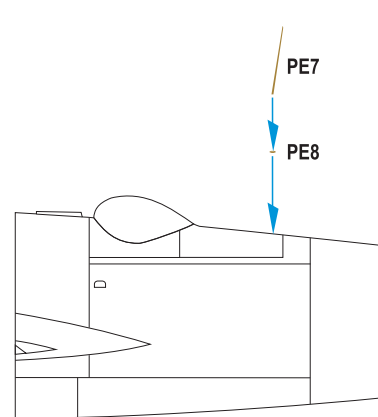
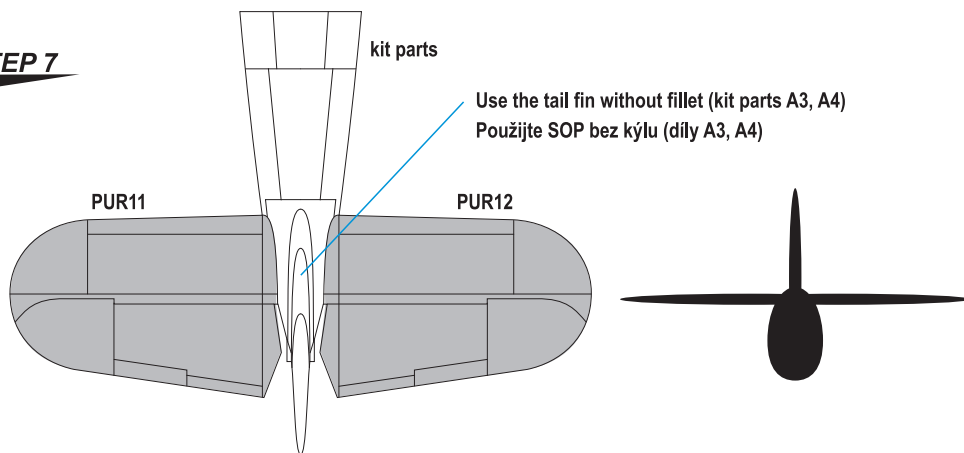

For your Beaufighter Mk.II model also get CMK resin wheel set no.7480.
Pro stavbu modelu Beaufighter Mk.II doporučujeme použít CMK resinová kola 7480

7480 Beaufighter Mk.I/VI Mainwheels
1/72 Early Wheel Disk / Smooth Tyre
for Airfix and others Beau kits
PUR - Polyurethane parts

1
1

© Special Hobby 2021