

5 Zbarvení / Painting

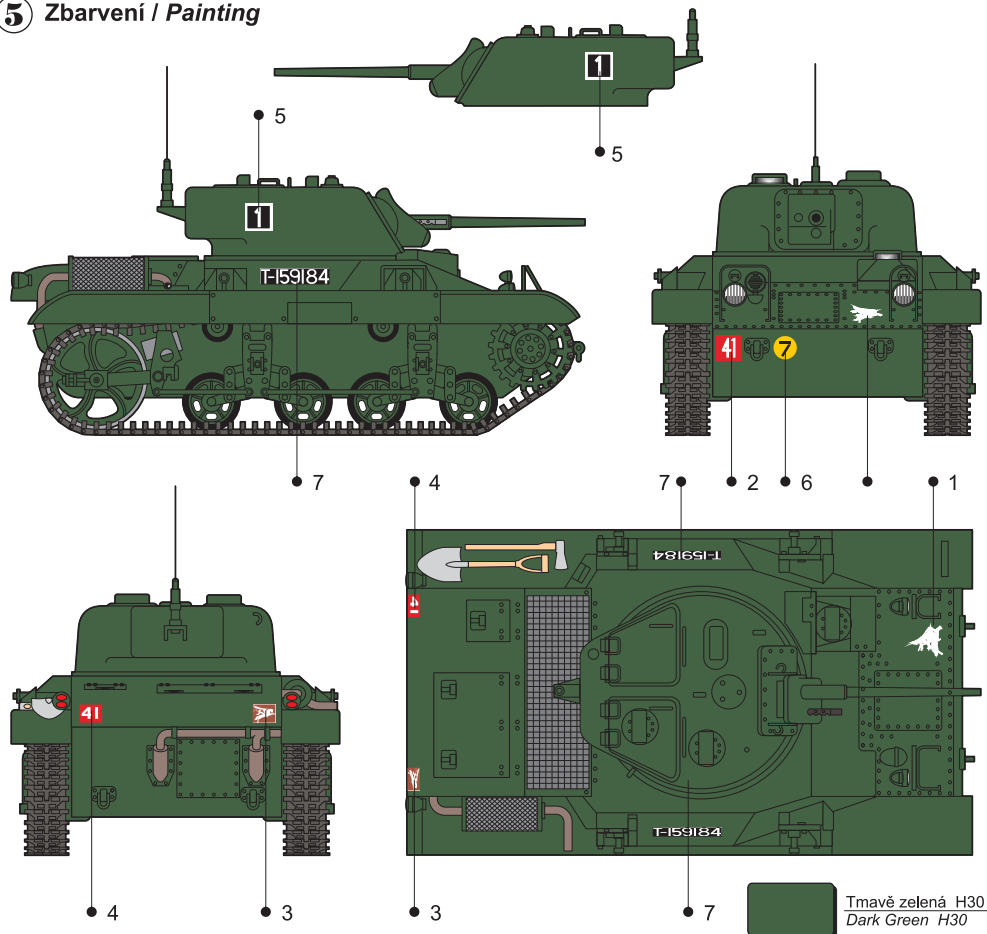

M22 "Locust" Britská 6.výsadková divize, - operace Varsity - březen 1945
 M22 "Locust" British 6.Airborne Division, - Operation Varsity - March 1945

BARVY / COLORS

HUMBROL

A	Černá / Black	33
B	Ocelově šedá / Steel grey	11+87
C	Dřevo / Natural wood	110
D	Rez / Rust	113
E	Kovová / Gunmetal	53
F	Barva pásů / Track Colour	173

Special Hobby, Mezilesí 718, CZ - Praha 9, 193 00, e-mail: office@specialhobby.eu



Detailní resinový model
obsahující fotoleptané díly a obtisky

MV 103

1/72

M22 "Locust" Airborne Tank

Visit an official website and e-shop at www.cmkkits.com

www.specialhobby.eu

PUR (polyuretan parts)

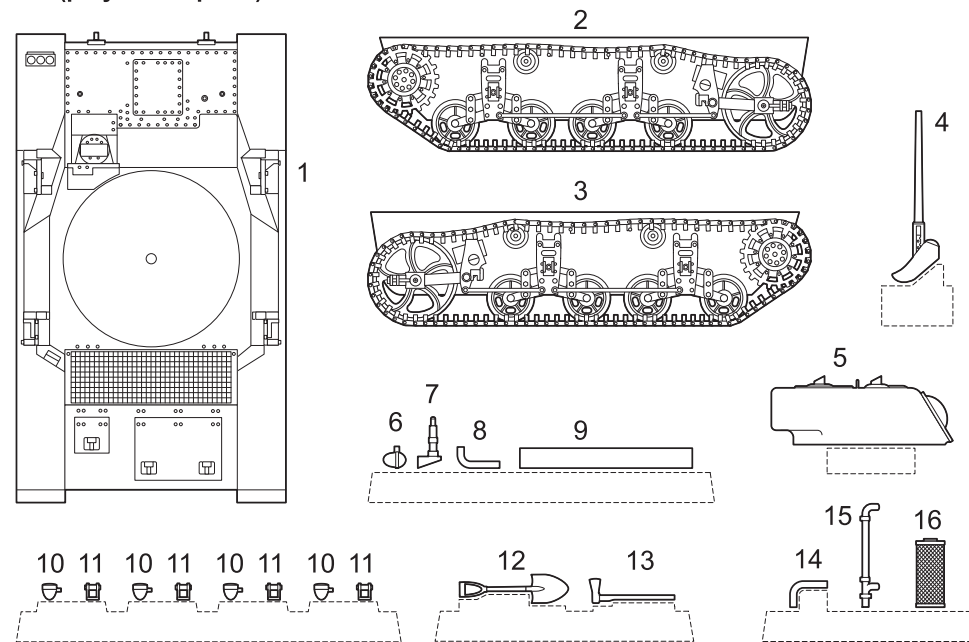

Obtisky/Decals

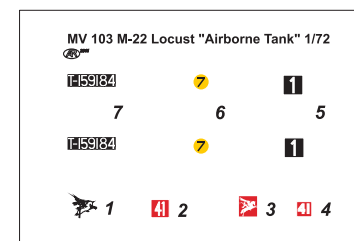

<https://www.facebook.com/specialhobby/>

Díly ohnuté popř. pokroucené vlivem teplotních změn a stárnutí materiálů, mohou být narovnané do požadovaného tvaru pomocí proudu teplé vody nebo vzduchu (fén na vlasy). Různé drátky a tyčinky nejsou přiloženy. Kontaktní plochy doporučujeme před lepením odmastit.

Parts slightly distorted and bended owing to temperature changes or due to material ageing can be straightened to requested shape by hot water or hot air jet. (hair dryer) This process can be repeated till result is entirely satisfactory. Wires and holes not included. Contact areas ungrease is recommended before gluing

1 Montáž pásového podvozku / Tracked mounting undercarriage

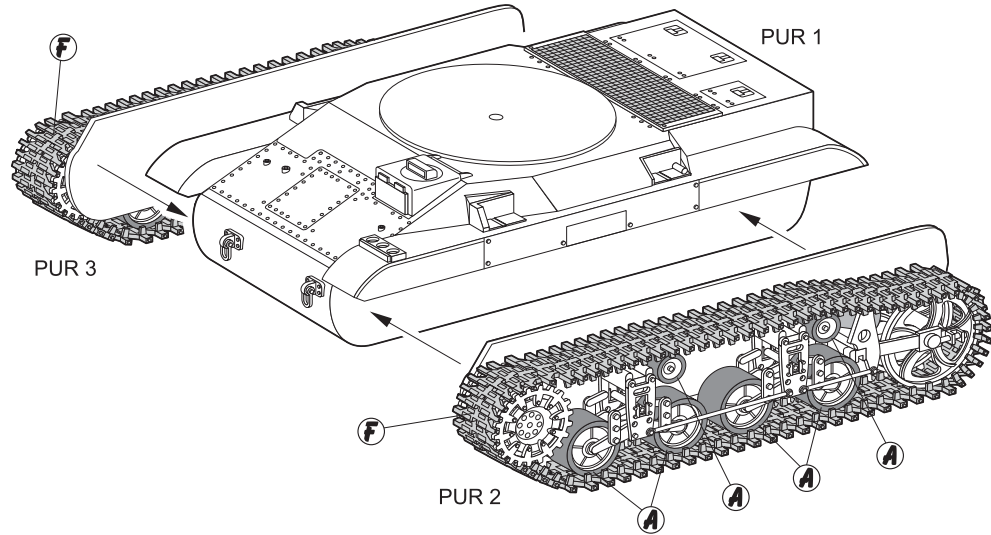

2 Montáž detailů korby / Details of the hull assembly

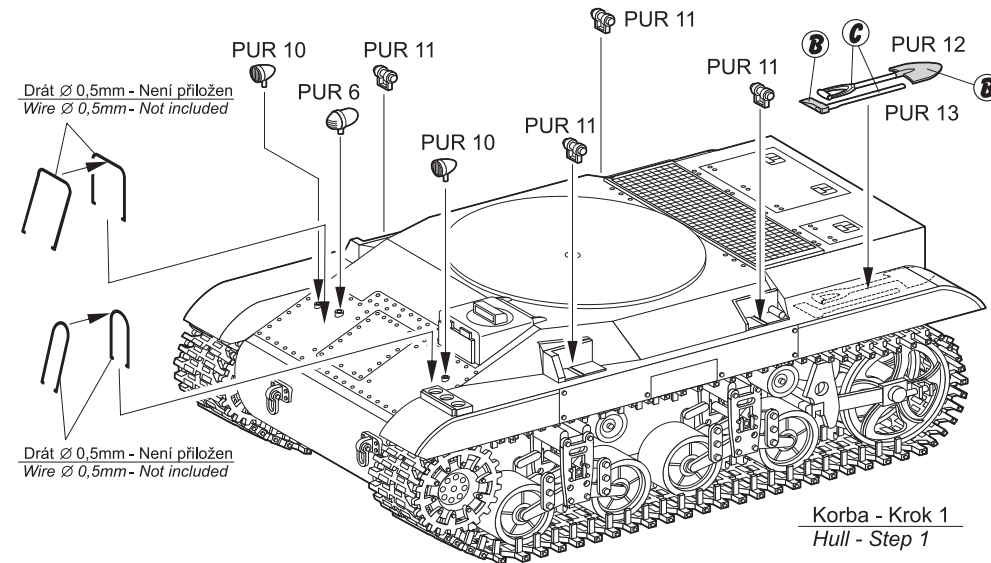

3 Sestavení věže / Turret assembly

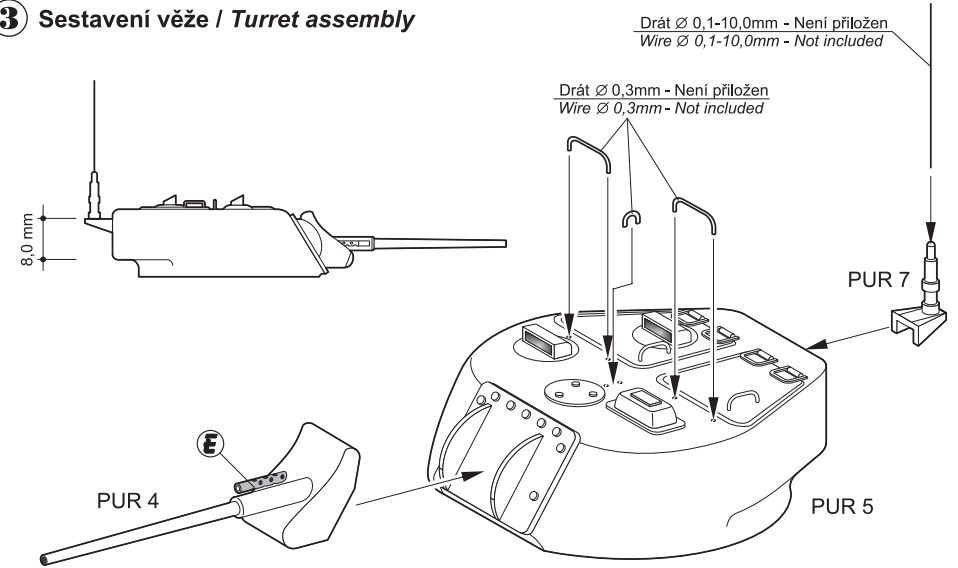

4 Montáž výfuku / Exhaust assembly

