

Folland Gnat F.1 British Single Seaters **SIMPLE SET**



H. P. Folland pracoval jako šéfkonstruktor firmy Gloster až do poloviny třicátých let minulého století. Rozhodl se ale osamostatnit se a založil firmu Folland Aircraft Ltd. (původně British Marine Aircraft Ltd.). Během druhé světové války se stala významným subdodavatelem dílů pro velké výrobce a postavila několik expedimentálních letadel.

V roce 1950 k této firmě nastoupil známý konstruktér W. E. Petter (autor Lysanderu, Whirlwindu či Canberra). V té době se vývoj a provoz moderních proudových stíhaček stával stále dražším. Tak jak stíhačkám rostly výkony, tak se zvětšovaly jejich rozměry a komplikovalo se jejich vybavení. Konstruktor W.E. Petter se rozhodl jít jinou cestou a pro Folland navrhl lehký stíhací letoun poháněný v projektech nejprve dvěma, později jedním proudovým motorem. Při minimálních rozměrech, nenáročném vybavení a hlavně třetinové ceně měl nabízet stejné výkony jako podstatně větší stroje.

Původní projekt předpokládal, že pilot bude ležet v přídě a pohánět jej budou dva motory o malém výkonu. Vedení společnosti se tak radikálního projektu obávalo a tak W.E. Petter vypracoval několi dalších studií. Velký problém způsobil výběr vhodného motoru. Uvažované motory se nezačaly vyrábět. Nakonec byl použit motor Bristol Orpheus. S ním také vzletl testovací Fo. 139 Midge, který měl ověřit aerodynamickou koncepci stroje. 18. června 1955 vzletl poprvé prototyp Gnatu (tovární označení Fo. 145). Přitom již v březnu téhož roku objednal ministerstvo dodávek šest testovacích strojů. Ty byly dodány v roce 1956 a důkladně testovány. Vykázaly vynikající vlastnosti, dosahovaly vysoké podzvukových rychlostí, byly vyjimečně obratné ve všech výškách a skvěle akcelerovaly. Tyto výkony vedly dva státy k tomu, aby Gnaty zařadily do výzbroje.

Finsko odebralo dvanáct strojů, deset ve stíhací a dva v průzkumné variantě. Indie zakoupila dvacetpět sestavených strojů, dvacet dalších v dílech a licenční práva pro domácí továrnu HAL. Ta vyrobila stodevadesát pět Gnatů v licenci. Poslední dva kusy se staly prototypy indické úpravy Ajeet Mk. 1. Té bylo vyrobeno sedmdesátdevět kusů (sériová výroba běžela od roku 1976) a dalších deset bylo upraveno z dodaných Gnatů. Zatím co finské Gnaty strážily finskou neutralitu, indické byly bojově nasazeny. Během indicko-pákistánské války v roce 1965 se překvapivě staly nejuspěšnějšími letouny konfliktu. Snadno dokázaly vymanévrovat F-86 Sabre, ale poradily si i s o generaci mladšími F-104A. Vzhledem k malým rozměrům a obratnosti byly schopny vymanévrovat střely Sidewinder. Navíc pákistánští piloti měli problém Gnat spatřit, natož zaměřit. Podobě si Gnaty vedly i v dalším konfliktu v roce 1971. Ajeety indické letectvo vyřadilo až v roce 1991.

Dva kusy testovala také Jugoslávie, ale další neobjednala. RAF nakonec i přes úspěšné testy Gnaty ve stíhací verzi do výzbroje nezařadilo. Dle požadavků RAF ale vznikl Fo. 144 Gnat Trainer, pozdější úspěšný cvičný stroj Gnat T.1. Ten se ovšem od stíhacího Gnatu dosti liší.

rozpětí: 6,73 m, délka: 8,74 m, max. rychlost: 1118 km/h, max. stoupavost: 101 m/s, dostup: 15 240 m, dolet 1600 km, výzbroj: 2x kanón Aden ráže 30 mm, podvěšené rakety (10x až 18x, podle typu) či bomby 227 kg (2x)



During the late 1930s, HP Folland was employed as chief-designer for the Gloster Aircraft Company but he left to set up his own company called British Marine Aircraft Ltd which later became Folland Aircraft Ltd. This company became an important subcontractor for several other bigger companies and HP Folland also designed and built some experimental aircraft during WW2.

In 1950, WE Petter, who was famous for designs such as the Lysander, Whirlwind and Canberra joined Folland's company. By this time modern jet aircraft were becoming bigger, more complex and expensive as their performance increased and as a result the development and operating costs were rising too. WE Petter decided to pursue a different approach to the modern jet-fighter philosophy by designing a light-weight fighter aircraft which was to have been powered by a pair of low thrust turbojet engines although this was later changed to a single power unit as their power output of jet engines increased.

By choosing to build this new jet aircraft to the smallest overall dimensions possible and with only the very basic equipment required for the job this kept the total overall price down to only a third of the price of a standard jet fighter bomber of the day yet it would offer similar performance to these much bigger and more expensive jets. The initial design incorporated a pilot lying in a prone position in the nose of the aircraft and a twin engine configuration but the company's management was rather afraid of such revolutionary design and asked for some more conventional designs to be put forward instead. Finding the right engine was also causing concern because the original low thrust engine design intended for the project did not reach production standard and was discontinued so Petter chose a single Bristol Orpheus engine instead. This was used in the Fo. 139 Midge test aircraft which had been designed and built to assess the aerodynamical features of the future Gnat.

The Air Ministry ordered six trials aircraft off the drawing board during March 1955 and first prototype of the Gnat, known also as the Fo. 145, took off for the very first time on the 18th June 1955. All six development aircraft were delivered by 1956 and they underwent a very thorough set of flight tests, during which the design displayed excellent performance. The Gnat was found to be capable of high sub-sonic speeds, it was exceptionally manoeuvrable at high altitudes and due to its low weight and powerful engine the acceleration was phenomenal.

Two countries, Finland and India, found the results of these trials so very interesting that they decided to acquire the type for their air forces. Finland ordered twelve aircraft, ten of which were in a standard fighter configuration while two machines were adapted to carry out reconnaissance missions with cameras fitted in their nose. India acquired twenty-five complete machines of British origin while another twenty were provided in kit form to be assembled in India by HAL and HAL also acquired a licence to manufacture the Gnat in India. The Indian production line turned out at least one hundred and ninety-five airframe although the last two Indian Gnats were in fact prototypes of the improved Ajeet Mk.1 version. Production of this improved design began in 1976 and reached a total of seventy-nine Ajeets, with another ten Ajeets being created using modified Gnat airframes.

While the Finnish Gnats protected the neutrality status of their country, the Indian machines took part in hot conflict during the Indo-Pakistani War of 1965. Rather surprisingly, they became the most effective combat type of this war as they were capable of not only out-maneuvring the F-86 Sabre but also the more modern and much faster F-104A Starfighter. Due to their diminutive size and excellent manoeuvrability, the tiny Gnat was able to "shake-off" Sidewinder air-to-air missiles and it was also very hard for Pakistani fighter pilots to catch a sight of, let alone shoot down. Indian Gnats also proved just as successful during the later conflict against Pakistan which ended in 1971. The improved Ajeet remained in Indian service long after the Gnat was retired and these served until at least 1991.

Two Gnats were also used for trials by the Yugoslav Air Force but no further machines were ordered and despite successful trials in the UK, the Gnat F.1 fighter version was never ordered by the RAF. The RAF did however order a highly modified two seat trainer version called the Fo. 144 Gnat Trainer, later to be renamed the Gnat T.1 which had been designed to meet RAF specification and these proved to be very popular with the RAF, although some two seat Hunters were retained for pupils who could not fit into the diminutive Gnat and also for foreign exchange students.

Wingspan: 6.73m, Length: 8.74m, Max. Speed: 1,118 km/h, Max. Rate of Climb: 101m/s, Ceiling: 15,240m, Range: 1,600km, Armament: 2x 30mm Aden cannon, under-wing rocket projectiles (up to 10 or 18 pcs depending on a type, or 2 bombs of 227kg)

**The kit contains only plastic parts and instructions!
It does not contain decals or other components.**

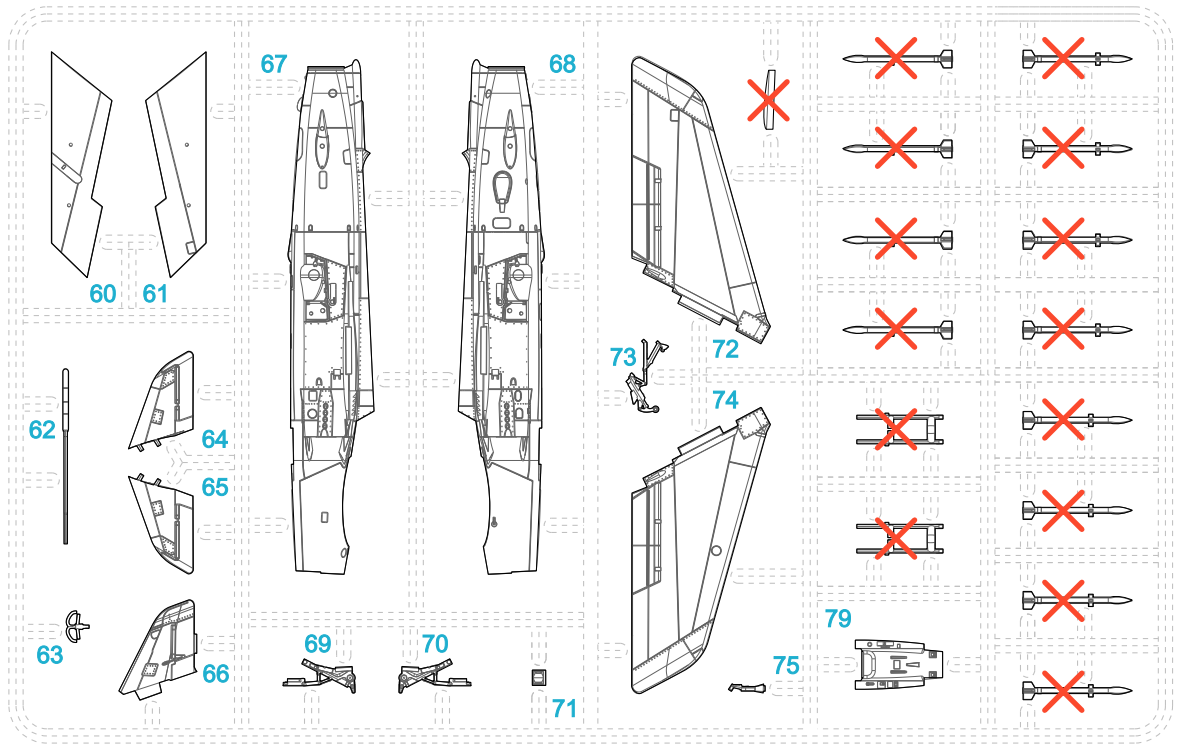
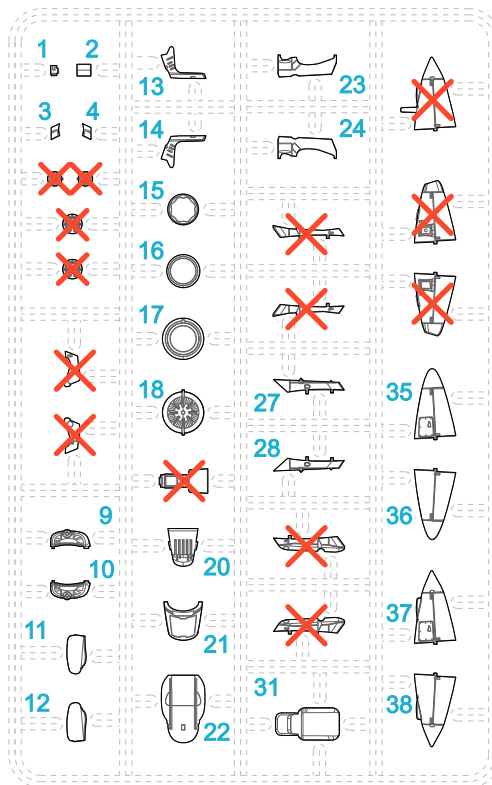
A**B****C**

Tento díl nepoužít
= Do not use this part

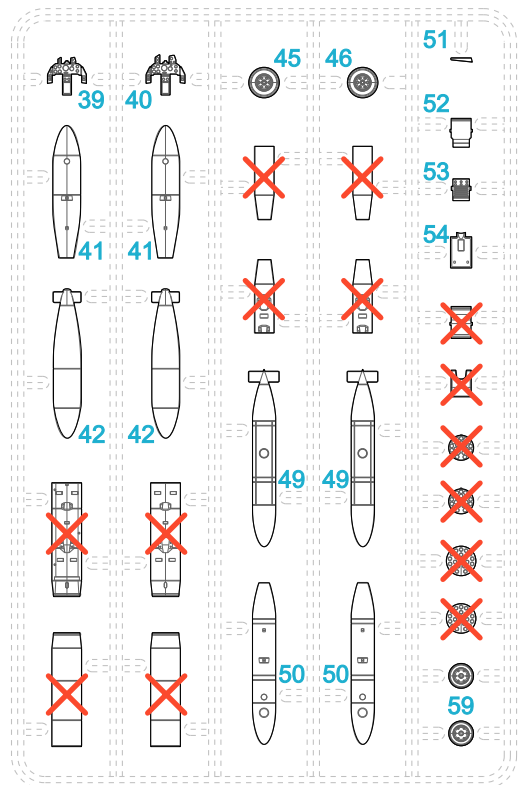
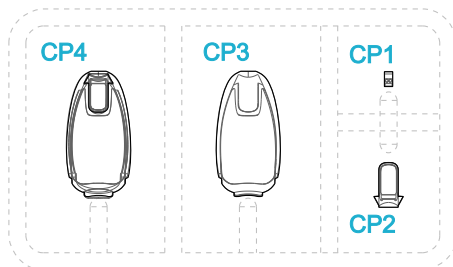
**D****CLEAR Parts****E****SYMBOLS**

MOŽNOST VOLBY
OPTIONAL
NACH BELIEBEN
OPTION



POUŽÍT KYANOAKRYLÁTOVÉ LEPIDLO
INSTANT CYANOACRYLATE GLUE
ZYANOAKRYLÄTKLEBER
ADHÉSIF CYANOACRYLAT



OHNOUT
BEND
BIEGEN
COURBER



ZHOTOVIT NOVĚ
SCRATCH BUILD
FERTIGSTELLEN
ACHEVER



ŘEZAT/VRTAT
CUT OFF/DRILL
ENTFERNEN
DETACHER



colours code

NATRÍT
COLOUR
FARBEN
PEINDRE

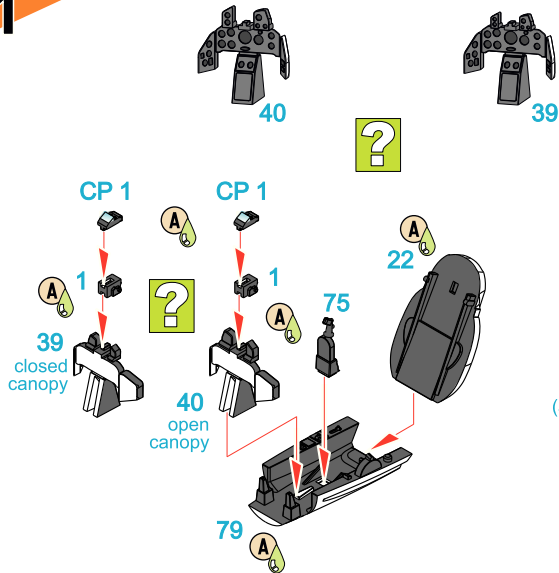
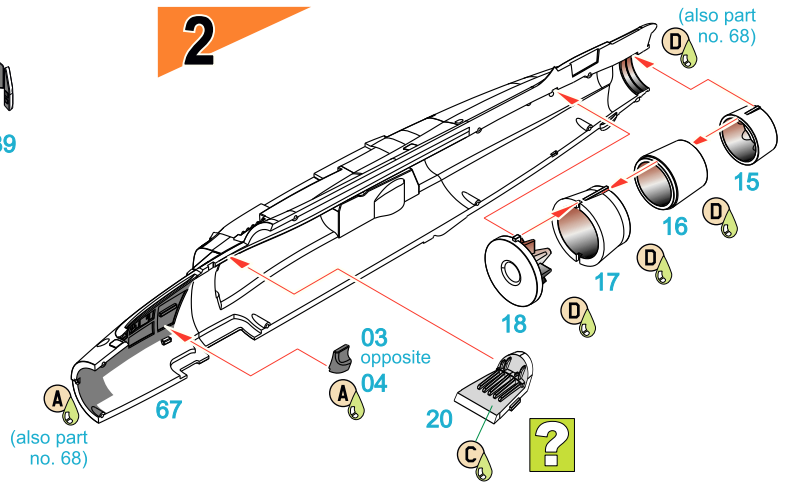
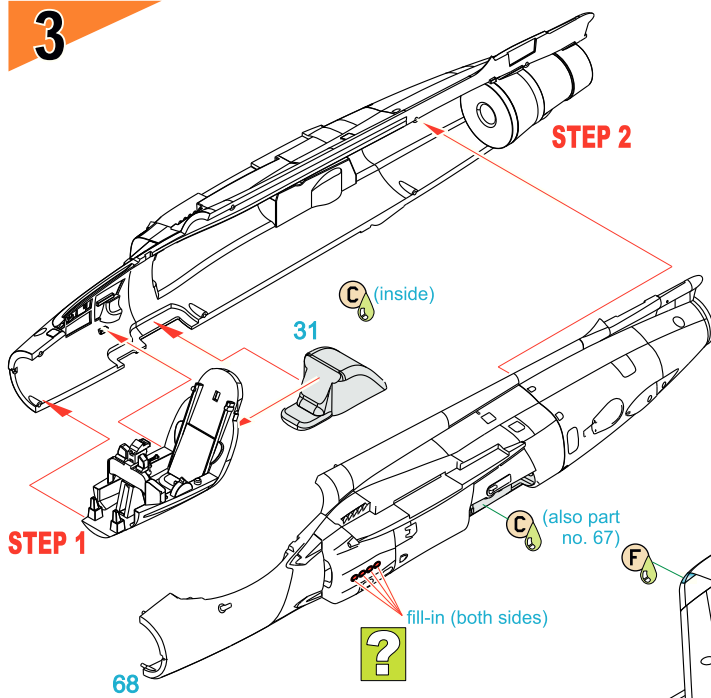
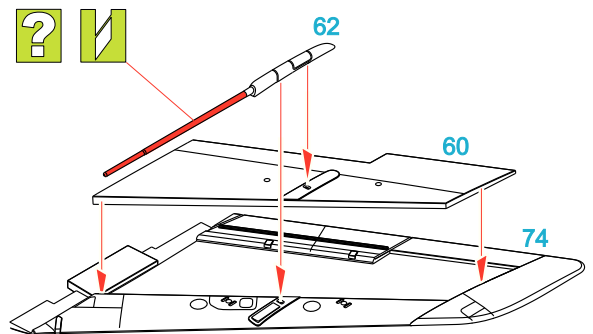
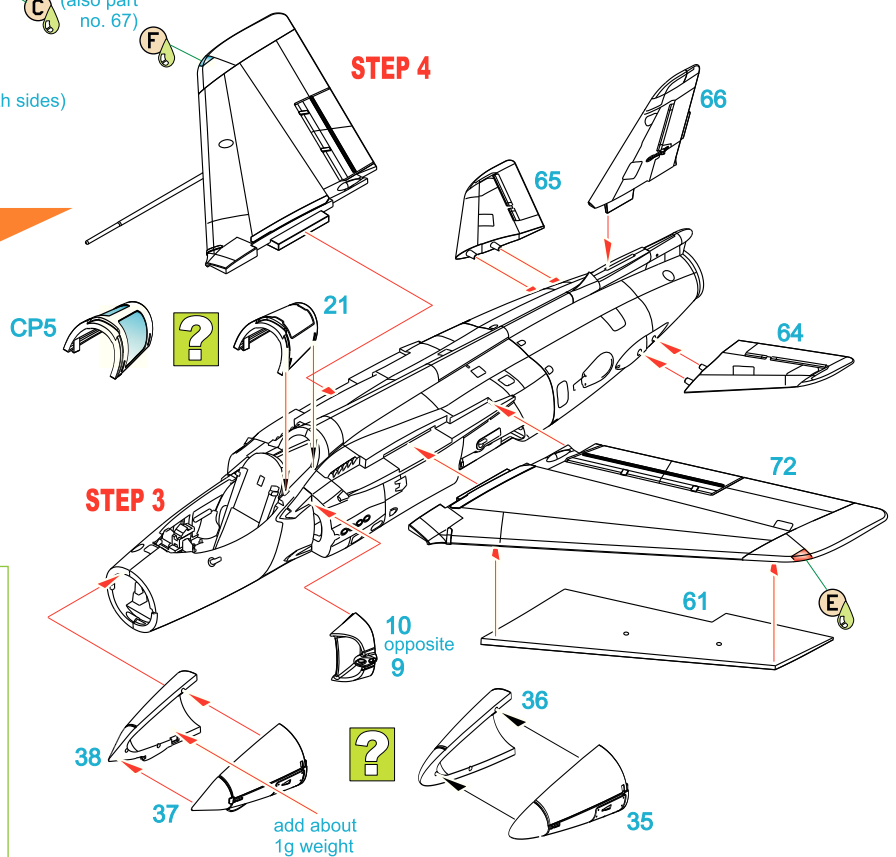
1**2****3****4****5****Barvy GUNZE/ GUNZE Colour No.**

A	Tmavě šedá / DARK GREY	H416/C116
B	Černá / BLACK	H12/C33
C	Hliník / ALUMINIUM	H8/C8
D	Opálený kov / BURNT IRON	H47/C41
E	Červená čirá / CLEAR RED	H90/C47
F	Modrá čirá / CLEAR BLUE	H93/C50
G	Barva pneu / TIRE BLACK	H77/C137
H	Červená / RED	H3/C3

6

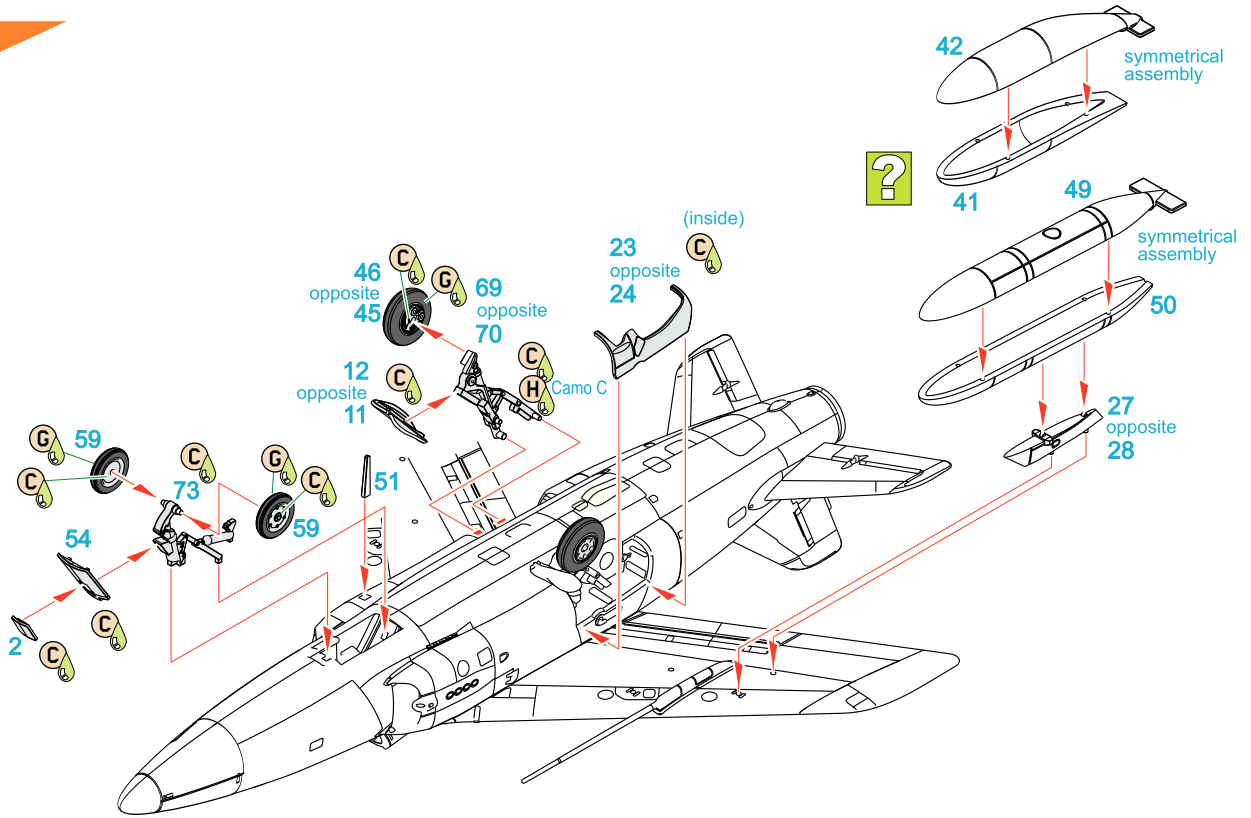

7

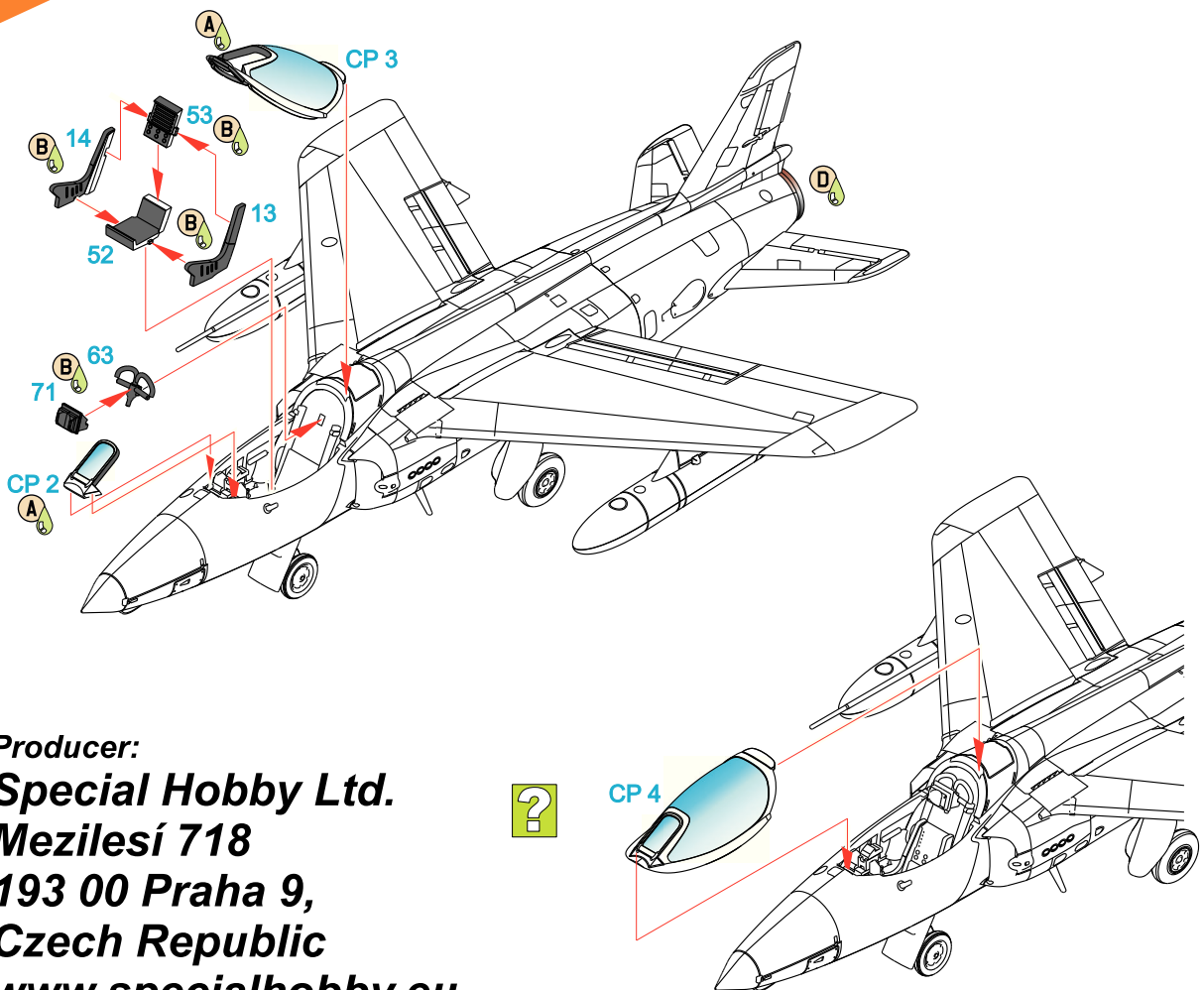

Producer:
Special Hobby Ltd.
 Mezilesí 718
 193 00 Praha 9,
 Czech Republic
www.specialhobby.eu