

Před vypuknutím války americké ozbrojené síly projeví zájem o nové výcvikové letadlo. V tu dobu firma Fairchild již začala projektovat nový monoplošník vhodný pro armádní požadavky tak i pro civilní letecké školy. Letoun byl konstruován pod označením Model 62 Armandem J. Thieblotem s nekonvenčním křídlem, jež pomáhalo pilotním žákům vyhnout se nedobrovolnému přechodu do vývrtky při pádové rychlosti. Stroj byl zalétnut v roce 1938 a o rok později dostal Fairchild objednávku od U.S. Army jako výsledek soutěže vypsané US. Air Corps. Cvičné letouny Fairchild vstoupily do služby v roce 1940 pod označením PT-19A. V USA jich byly postaveny stovky a licenčně se stavěli i v Kanadě. Do roku 1944 absolvovalo nejvíce druhoválečných pilotů základní výcvik právě v letounech Fairchild.

Before the outbreak of WW2, the U.S. military services announced their interest in a new training aircraft. The Fairchild had already begun to design a new monoplane suitable for Army requirements as well as for civilian flying schools. Designed as "Model 62" by Armand J. Thieblot, it featured an unconventional wing, which aimed to help student pilot avoid stall/spin accidents. The first test flight was made in 1938 and a year later, following an Air Corps contest, the Fairchild was awarded a contract by the U.S. Army. Designated the PT-19, the Fairchild trainers entered service in 1940, with hundreds being manufactured both in USA and under licence in Canada. By 1944 more WW2 pilots had received their initial flight instruction in the PT-19, than in any other aircraft.

Specifikace: motor 6-440-C5 s výkonem 200k, rozpětí 10.97 m, délka 8.51 m, výška 2.28 m, váha 840 kg, max. rychlost 206 km/h, dostup 4572 m, dolet 692 km.

Specifications: engine 6-440-C5 with 200hp output, span 36 ft, length 27 ft 11 in, height 7 ft 6 in, weight 1851 lb empty, max. speed 128 mph, ceiling 15 000 ft, range 430 miles.

PARTS

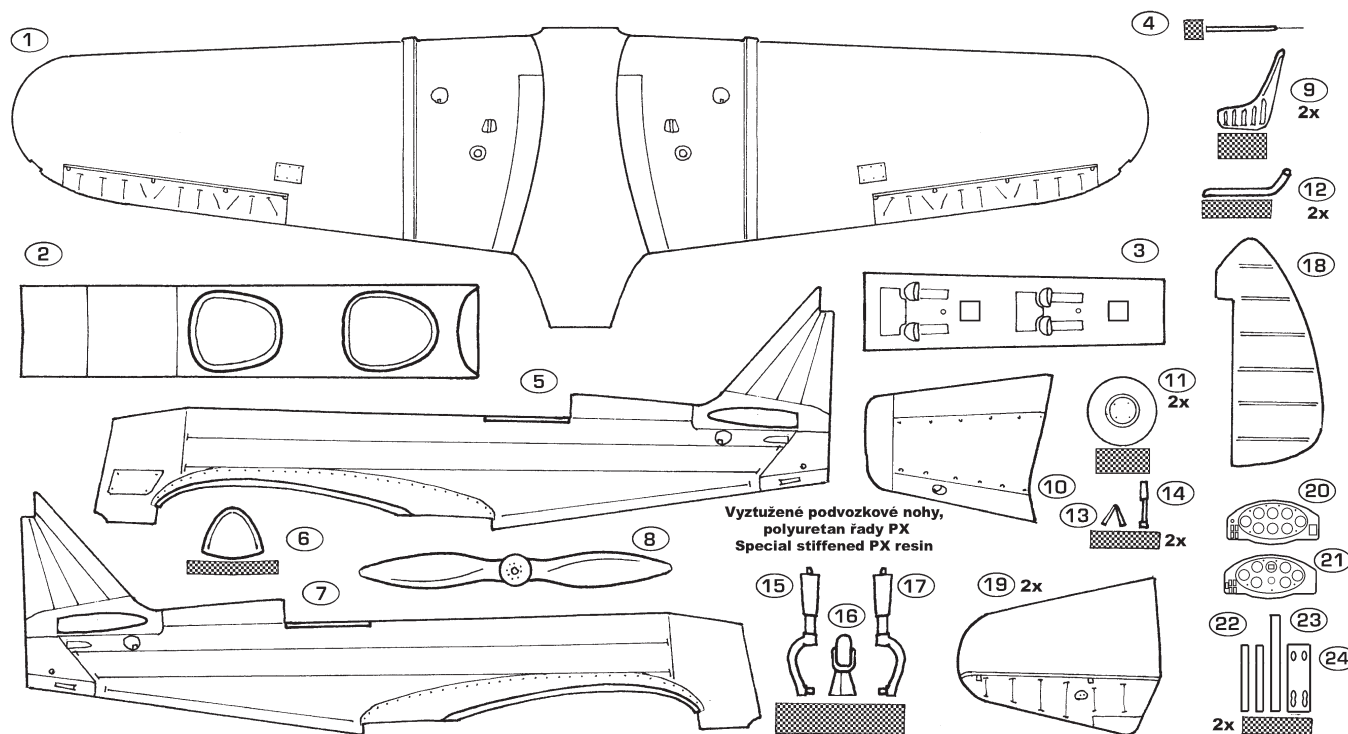

DECALS 1 - 22

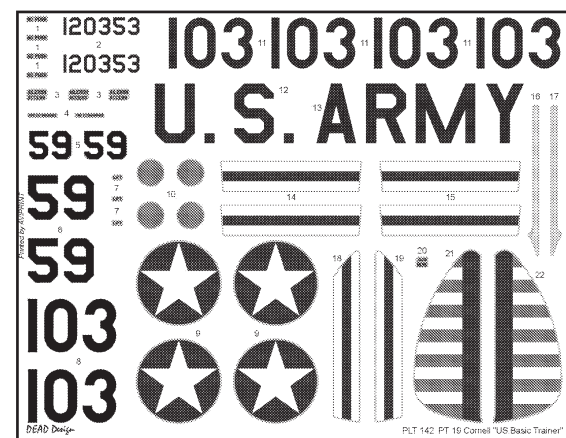

CLEAR (CP)

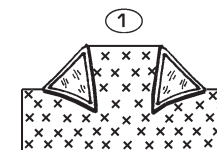

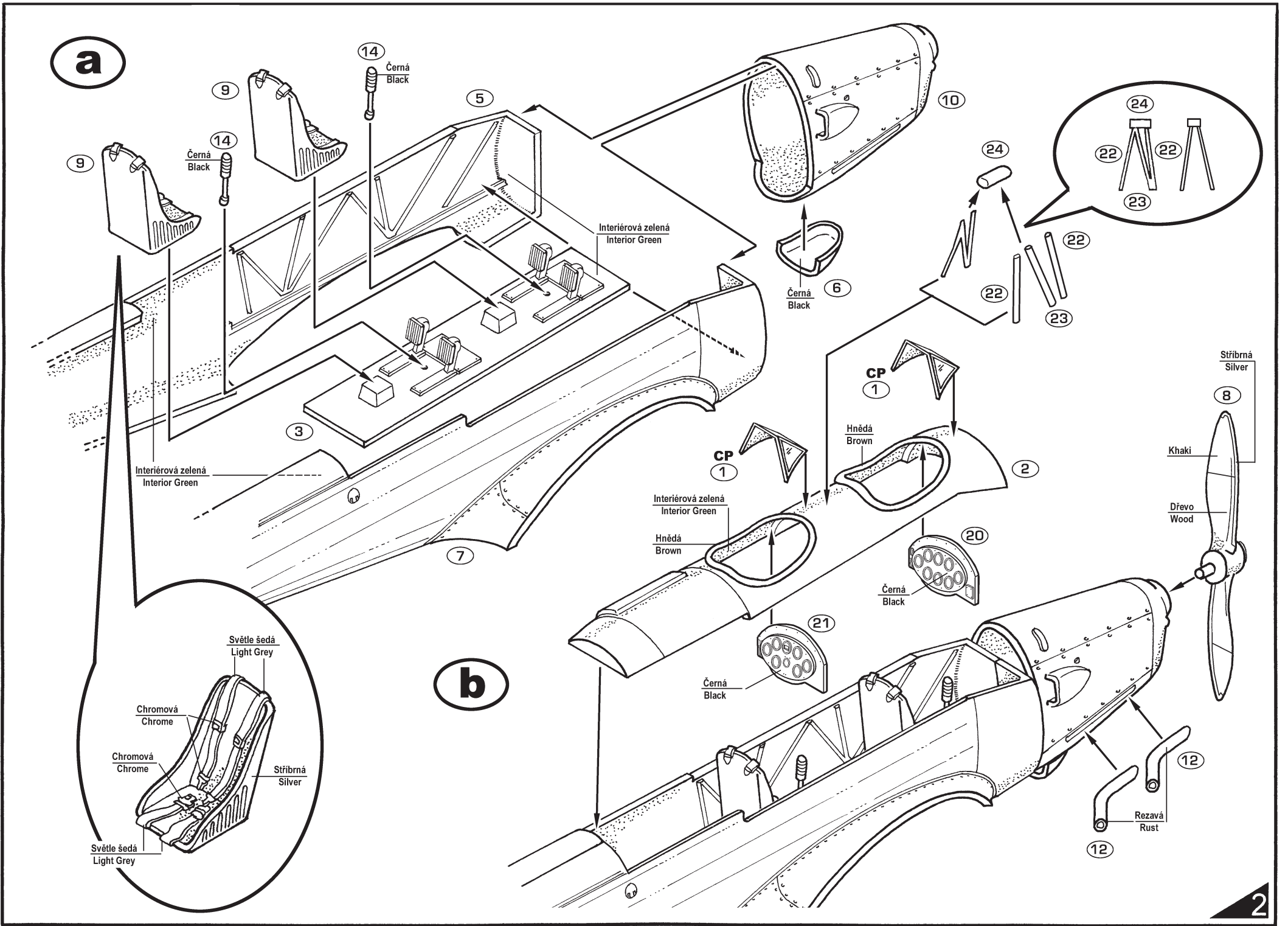

c

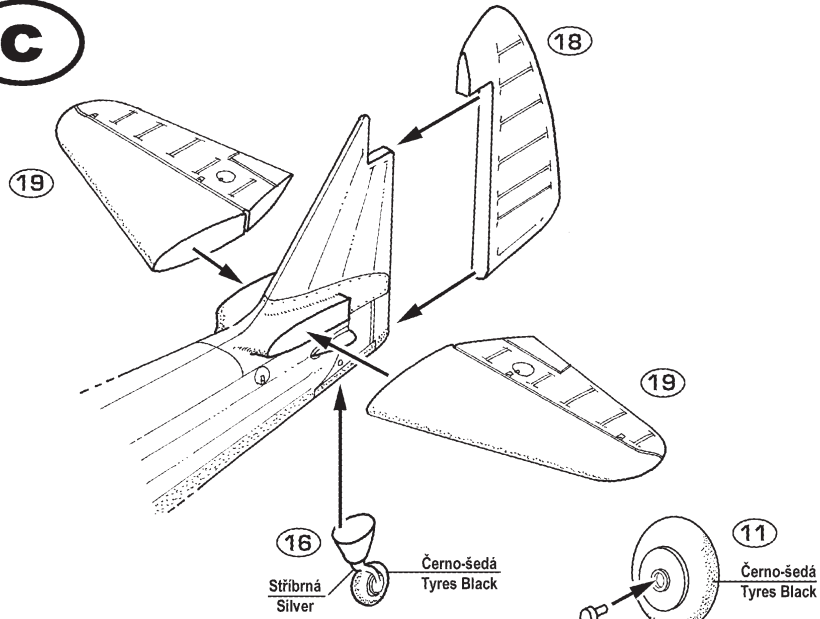

d

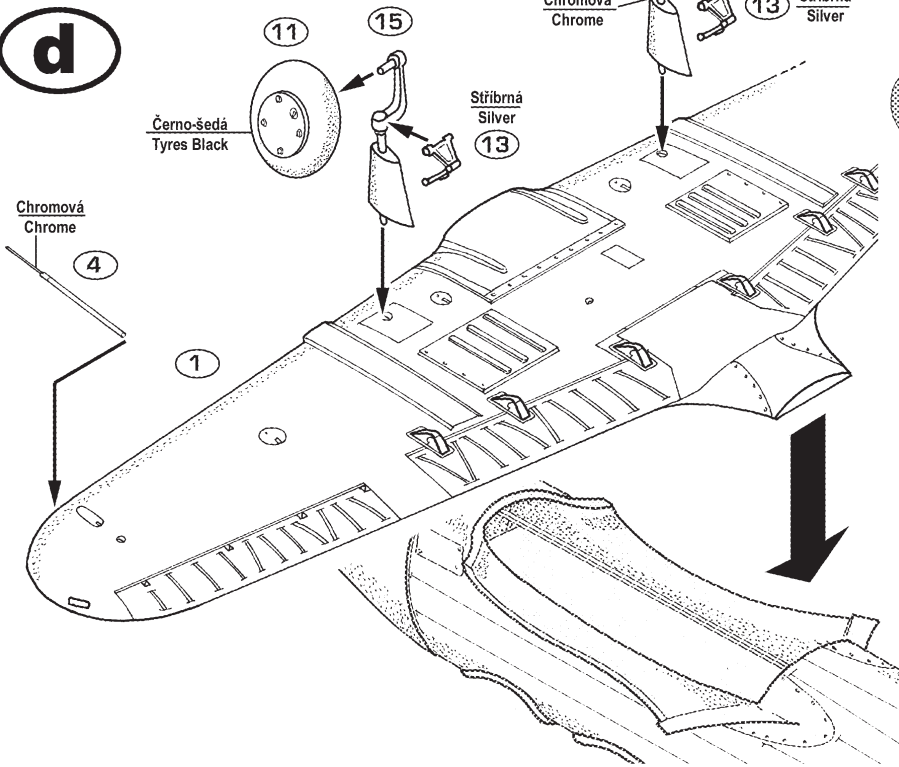

Fairchild PT-19A Cornell
U.S.ARMY Air Force 1940-41

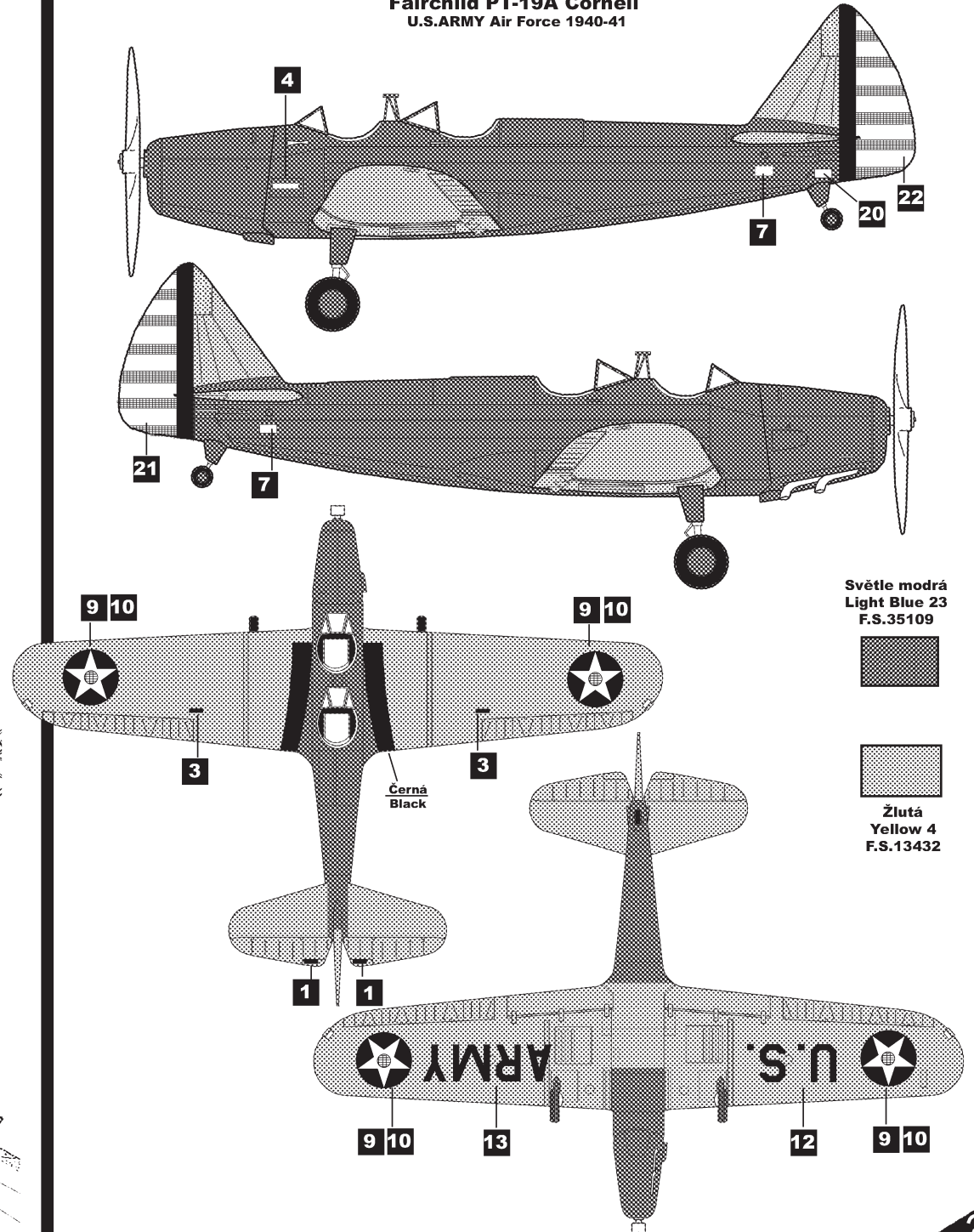

Světle modrá
Light Blue 23
F.S.35109

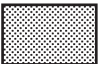

Žlutá
Yellow 4
F.S.13432

Fairchild PT-19A Cornell
U.S.ARMY Air Force 1942

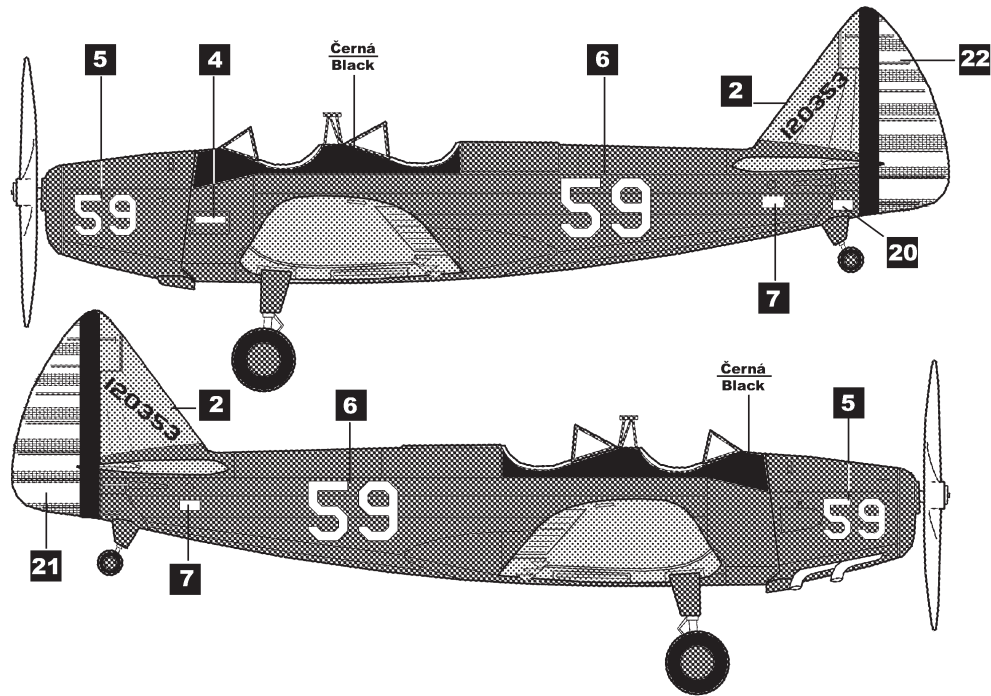

Fairchild PT-19 Cornell
Norwegian air training base
"Little Norway" at Toronto
Canada 1942-44

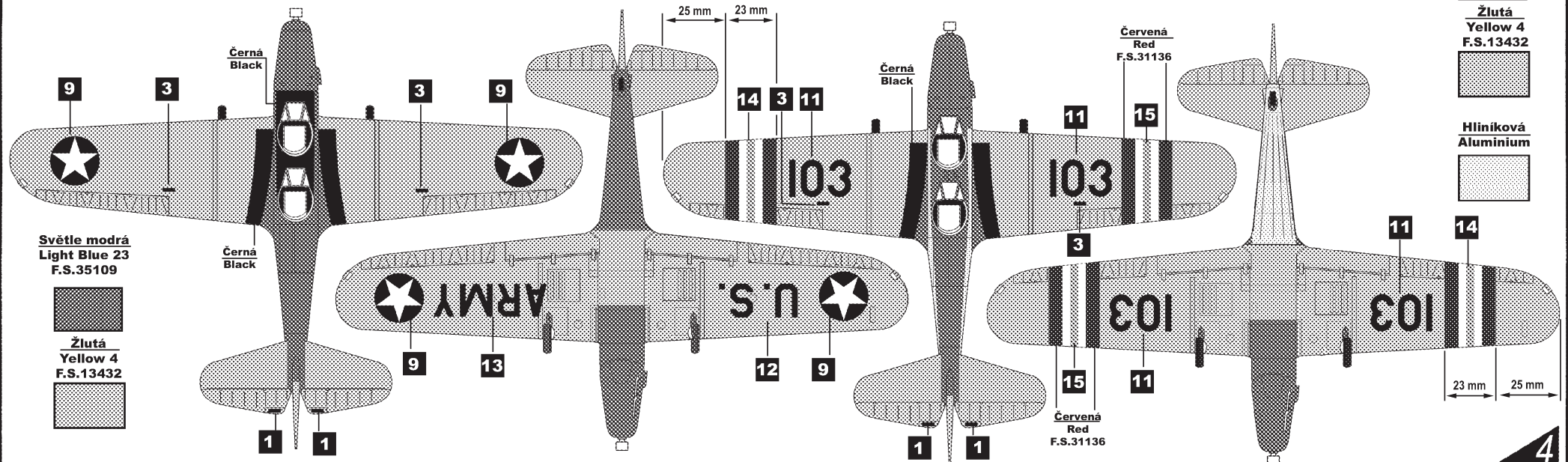
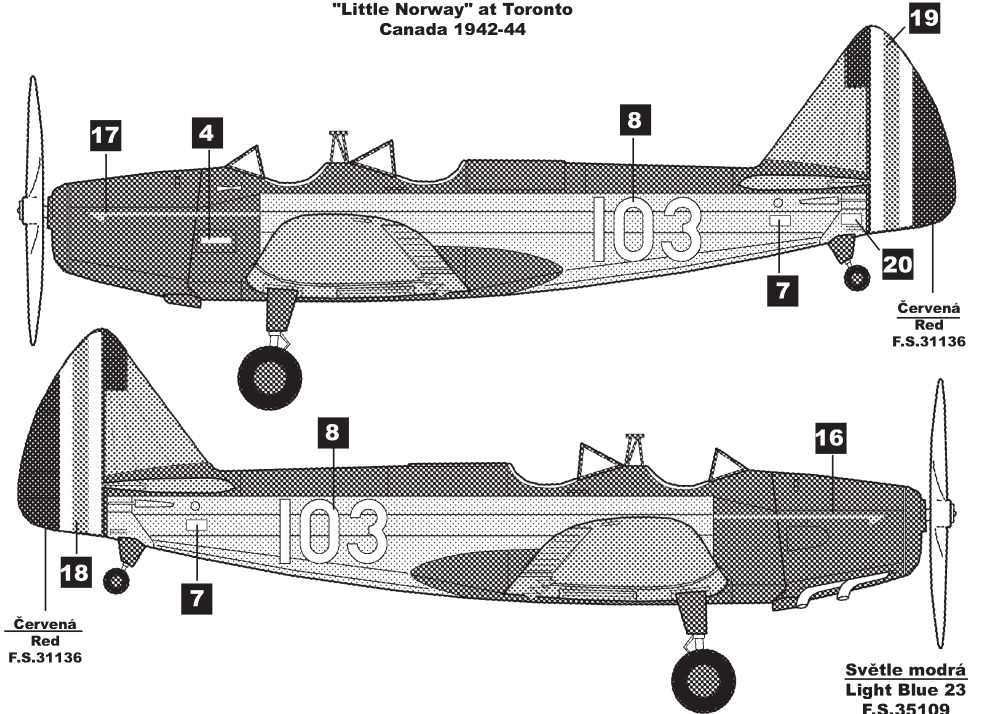

Světle modrá
Light Blue 23
F.S.35109

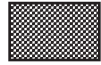

Žlutá
Yellow 4
F.S.13432

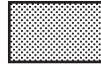

Hliníková
Aluminium

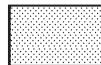

Světle modrá
Light Blue 23
F.S.35109



Žlutá
Yellow 4
F.S.13432



Cervená
Red
F.S.31136

Cervená
Red
F.S.31136